

Item No.

Quantity.

Job Name.

Model 407

Counter Model

Twist Soft Serve Ice Cream/Yogurt Machine



Compact Soft Serve Ice Cream/Yogurt Machine For Low Volume Operations

Maximize Your Profits – Combine efficiency with consistent product quality and fast quiet operation to insure customer satisfaction with high profit ice cream products.

Add to Your Product Offering – You can offer products like sundaes, milk shakes, flurries and cones.

Fast Service – Just pull the spigot handle to dispense the product.

Volume of Product – Provides two 4 oz. servings per minute. Quick recovery insures availability of product for low volume operations.

New Tamper Proof Mix Out System- Solid state, tamper proof mix out system alerts the operator when product in the reservoir is low.

State of the Art Mix Out System – Tamper Proof system alerts the operator when product in the reservoir is low and needs to be replenished.

Mix Pan Agitator – Insures even, safe temperature of product in the mix reservoir.

Fast, Easy Clean – SaniServ equipment is designed to be easily cleaned and sanitized, with the fewest parts possible for rapid assembly and disassembly.

Invest in Equipment Built to Last – SaniServ frozen beverage machines achieve long and dependable life through simplicity of design, durable steel frame construction, heavy duty components and automatic torque controlled consistency system. Shipped standard with stainless steel exterior.



"Reliability from the team that Serves the Best"

SaniServ®

2020 Production Drive
Indianapolis, IN 46241-4398
Ph. 317/247-0460 Fax: 317/247-5130

Counter Model Ice Cream/Yogurt Freezer

Factory Authorized Sales and Service

Distributed by:

Model 407

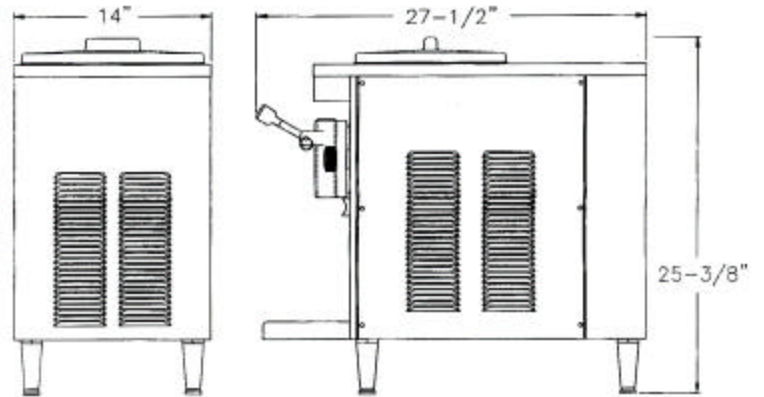
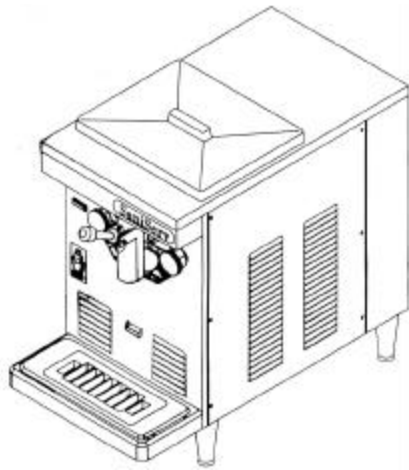

Wall Clearance 6" – Both Sides and Back

	WIDTH	HEIGHT	DEPTH	POWER	TOTAL AMP DRAW
MACHINE	14"	25-3/8"	27-1/2"	115/60/1Ø	15.6
CRATED	18-1/2"	25-1/2"	31-1/2"		Weight 155 pounds

Quick Recovery...
Compact and Durable...
Simple in design for easy cleaning....
Heavy duty components...

Electrical: 115/60 Hz/1Ø/15.6 Amps

Controls: Automatic consistency controls for improved product consistency.

Tamper Proof Automatic Visual Mix Out System for the protection of your investment.

Evaporator and Mix Reservoir Capacity: 10 Quarts

Construction: Welded Steel Support, Stainless Steel Exterior, Legs Standard.

Dasher: Heavy-Duty Stainless Steel with low friction scraper blades.

Dasher and Compressor Motors: 1/2HP Dashers 1/4HP Compressor

Approximate Weight: 145 lbs.

Shipping Volume: 8.6 Cubic Feet

Warranty:

Parts 1 year
Compressor 5 years

Equipment Options:

208-230/200-220-60/50/1Ø/10 Amp
Tune Up Kit

Listings: UL, cUL, NSF

We reserve the right to change specifications and product design without notice. Such revisions do not entitle the buyer to corresponding changes, improvements, additions or replacements for previously purchased equipment.