

Project

Item #

Quantity



GLOBE FOOD EQUIPMENT COMPANY

8 Quart Planetary Mixer

SP8



# SP8 Mixer

### Model

- SP8 - 8 Quart Planetary Mixer



### Standard Features

- **Motor and Transmission**
  - Gear driven, high torque transmission
  - Three fixed speeds
  - 1/4 HP custom built motor
  - Heat-treated hardened steel alloy gears and shafts
  - Permanently lubricated transmission
  - Thermal overload protection
- **Other**
  - Rigid cast aluminum base and column
  - Polycarbonate bowl guard
  - Front mounted controls
    - 15 minute digital timer
    - Separate start and emergency stop buttons
  - Safety interlock microswitches
    - Bowl guard
    - Bowl lift
  - 6 foot cord and plug

- **Standard Accessories**
  - 8 quart stainless steel bowl
  - Flat beater
  - Stainless steel wire whip
  - Spiral dough hook
- **Optional Accessories**
  - Stainless steel mixer table
- **Standard Warranty**
  - 2 year parts and one year labor

Approved By: \_\_\_\_\_

Date: \_\_\_\_\_



## GLOBE FOOD EQUIPMENT COMPANY

[www.globeslicers.com](http://www.globeslicers.com)

2268 N. Moraine Dr.  
 Dayton, OH 45439  
 Phone: 937-299-5493  
 Phone: 800-347-5423  
 Fax: 937-299-4147



# 8 Quart Planetary Mixer

# SP8

## Specifications

**Motor:** 1/4 HP, grease packed ball bearing, air cooled, 110/60/1, 5 amps. Thermal overload protection (manual reset).

**Finish:** Enamel white paint.

**Capacity:** 8 quart (7.6 liter) bowl.

**Transmission:** Heat treated, hardened alloy, precision milled gears operate with planetary action. Gears are packed in a long lasting grease. All shafts are mounted in ball bearings. Transmission gears are driven by direct linkage to the motor drive shaft. This design yields high torque mixing power.

**Agitator Speeds (RPMs):**

Low	132
Intermediate	284
High	590

**Standard Equipment:** Standard equipment includes an 8 quart #304 series stainless steel bowl, spiral dough hook, stainless steel wire whip, flat beater, polycarbonate bowl guard, and a 15 minute digital timer. A sturdy hand lever on the body column raises and lowers the bowl as well as locking in place at the top and bottom positions.

**Safety Features:** Separate start and emergency stop button so operators can shut down the mixer in an emergency situation, and microswitches that automatically shut the mixer down when the guard is opened or the bowl is lowered.

**Cord and Plug:** 6 ft. flexible three wire cord and ground plug.

**Dimensions:**

Foot Print = 11.8" x 15.8"  
(300 mm x 400 mm)  
Overall Length = 15.8" (400 mm)  
Overall Width = 11.8" (300 mm)  
Overall Height = 22.9" (580 mm)

**Shipping Information:**

Freight Class: 77.5  
Net Weight: 55 lbs. (25 kgs.)  
Shipping Weight: 60 lbs. (27 kgs.)  
Box Dimensions:  
14.1"W x 18.4"D x 25.8"H  
(358mm W x 467mm D x 655mm H)  
Cartons are reinforced for shipping. The weight and dimensions of this reinforced carton are not included above and may vary from shipment to shipment.

**Optional Accessories:**

**XTABLE** Stainless Steel Mixer Table with Undershelf

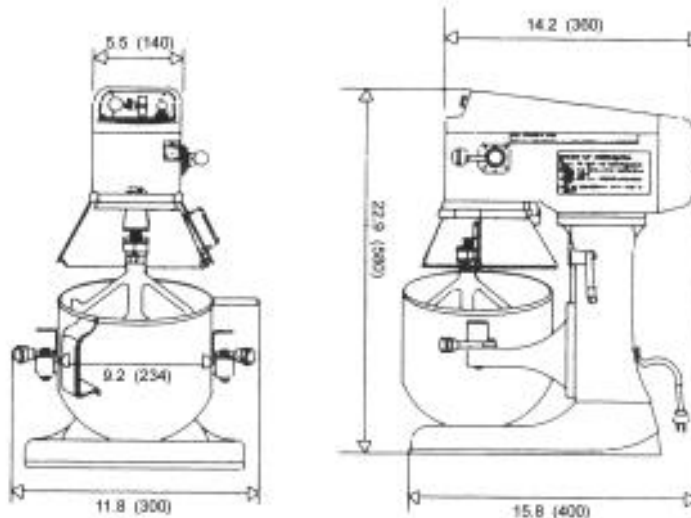

UNIT: INCHES (MM)



## GLOBE FOOD EQUIPMENT COMPANY

[www.globeslicers.com](http://www.globeslicers.com)

2268 N. Moraine Dr.  
Dayton, OH 45439  
Phone: 937-299-5493  
Phone: 800-347-5423  
Fax: 937-299-4147

Printed in U.S.A. 8-2003

Specifications are subject to change without notice.