

Project

Item #

Quantity



GLOBE FOOD EQUIPMENT COMPANY

40 Quart Planetary Mixer

SP40P



SP40P Mixer

Model

SP40P - 40 Quart Planetary Mixer



Standard Features

- **Motor and Transmission**
 - 2 HP custom built motor
 - Three fixed speeds
 - High torque transmission
 - Heat-treated hardened steel alloy gears and shafts
 - Permanently lubricated transmission
 - Thermal overload protection
- **Other**
 - Rigid cast steel base and column
 - Stainless steel bowl guard with built in ingredient chute
 - NSF approved enamel gray paint
 - Front mounted controls
 - 15 minute timer
 - Separate start and emergency stop buttons
 - #12 attachment hub
 - Safety interlock microswitches
 - Bowl guard
 - Bowl lift
 - 6 foot cord, no plug

Standard Accessories

- 40 quart stainless steel bowl
- Flat beater
- Stainless steel wire whip
- Spiral dough hook

Optional Accessories

- Vegetable slicer for #12 hub
- Shredder/grater for #12 hub
- Stainless steel meat grinder for #12 hub
- 20 quart adapter kit
- Bowl trolley

Standard Warranty

- 2 year parts and one year labor

Approved By: _____

Date: _____



GLOBE FOOD EQUIPMENT COMPANY

www.globeslicers.com

2268 N. Moraine Dr.
Dayton, OH 45439
Phone: 937-299-5493
Phone: 800-347-5423
Fax: 937-299-4147



40 Quart Planetary Mixer

SP40P

Motor: 2 HP, grease packed ball bearing, air cooled, 220/60/1, 17 amps or 208/60/3, 8 amps. Thermal overload protection (automatic reset).

Finish: NSF approved enamel gray paint.

Capacity: 42 quart (40 liter) bowl.

Transmission: Our fixed speed transmission is made of heat treated, hardened alloy, precision milled gears that operate the planetary action and provide high torque mixing power. The gears are packed in a long lasting grease, and all shafts are mounted in ball bearings.

Safety Features: Separate start and emergency stop buttons so operators can shut down the mixer in an emergency situation, and microswitches that automatically shut the mixer down when the guard is opened or the bowl is lowered.

Specifications

Agitator Speeds (RPMs):

Low 99
Intermediate 176
High 320

Attachment Speeds (RPMs):

Low 69
Intermediate 123
High 224

Standard Equipment: Standard equipment includes a 40 quart #304 series stainless steel bowl, spiral dough hook, stainless steel wire whip, flat beater, stainless steel bowl guard with built in ingredient chute, 15 minute timer, and #12 attachment hub. A sturdy hand lever on the body column raises and lowers the bowl as well as locking in place at the top and bottom positions.

Cord and Plug: Both single and three phase are hard wired.

Dimensions:

Foot Print = 25.0" x 24.5"
(632 mm x 622 mm)
Overall Length = 28.4" (721 mm)
Overall Width = 25.0" (632 mm)
Overall Height = 51.0" (1300 mm)

Shipping Information:

Freight Class: 77.5
Net Weight: 550 lbs. (250 kgs.)
Shipping Weight: 638 lbs. (290 kgs.)
Box Dimensions:
25"W x 29"D x 51"H
(635mm W x 737mm D x 1295mm H)
Cartons are affixed to a skid (pallet).
The weight and dimensions of this skid are not included above and may vary from shipment to shipment.

Optional Accessories:

XXACC20-40 Adapter Kit includes a 20 quart bowl, wire whip, dough hook, and flat beater to adapt 40 quart mixer to a 20 quart capacity.

XBTROLLEY Bowl Trolley

XMCA-SS Stainless Steel Meat Grinder (includes S/S cylinder, S/S end ring, S/S worm, S/S pan, stomper, 3/16" plate, and knock knife)

XVSA 9" Vegetable Slicer Assembly (includes an adjustable slicer plate)

XVGA 9" Shredder/Grater Assembly (includes a plate holder and 1 shredder/grater plate)

XSP332 3/32" Shredder Plate

XSP316 3/16" Shredder Plate

XSP516 5/16" Shredder Plate

XSP12 1/2" Shredder Plate

XGP Grater Plate

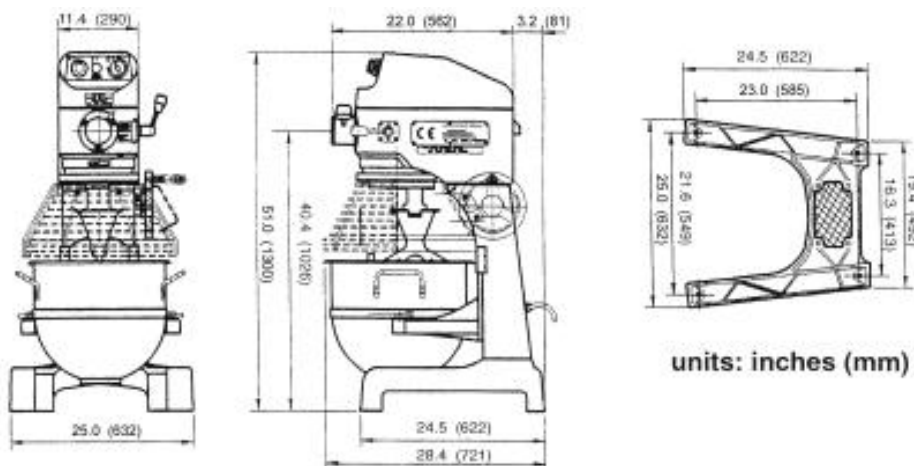

units: inches (mm)



GLOBE FOOD EQUIPMENT COMPANY

www.globeslicers.com

2268 N. Moraine Dr.
Dayton, OH 45439
Phone: 937-299-5493
Phone: 800-347-5423
Fax: 937-299-4147

Printed in U.S.A. 8-2003

Specifications are subject to change without notice.