

Project _____

Item # _____

Quantity _____



GLOBE FOOD EQUIPMENT COMPANY

10 Quart Planetary Mixer

SP10



SP10 Mixer

Model

- SP10 - 10 Quart Planetary Mixer



Standard Features

- **Motor and Transmission**
 - Gear driven, high torque transmission
 - Three fixed speeds
 - 1/3 HP custom built motor
 - Heat-treated hardened steel alloy gears and shafts
 - Permanently lubricated transmission
 - Thermal overload protection
- **Other**
 - Rigid cast steel base and column
 - Stainless steel bowl guard with built in ingredient chute
 - NSF approved enamel gray paint
 - Front mounted controls
 - 15 minute timer
 - Separate start and emergency stop buttons
 - #12 attachment hub
 - Safety interlock microswitches
 - Bowl guard
 - Bowl lift
 - 6 foot cord and plug

- **Standard Accessories**
 - 10 quart stainless steel bowl
 - Flat beater
 - Stainless steel wire whip
 - Spiral dough hook
- **Optional Accessories**
 - Vegetable slicer for #12 hub
 - Shredder/grater for #12 hub
 - Stainless steel meat grinder for #12 hub
 - Stainless steel mixer table
- **Standard Warranty**
 - 2 year parts and one year labor

Approved By: _____

Date: _____



GLOBE FOOD EQUIPMENT COMPANY

www.globeslicers.com

2268 N. Moraine Dr.
 Dayton, OH 45439
 Phone: 937-299-5493
 Phone: 800-347-5423
 Fax: 937-299-4147



10 Quart Planetary Mixer

SP10

Motor: 1/3 HP, grease packed ball bearing, air cooled, 110/60/1, 8 amps. Thermal overload protection (manual reset).

Finish: NSF approved enamel gray paint.

Capacity: 10 quart (9 liter) bowl.

Transmission: Heat treated, hardened alloy, precision milled gears operate with planetary action. Gears are packed in a long lasting grease. All shafts are mounted in ball bearings. Transmission gears are driven by direct linkage to the motor drive shaft. This design yields high torque mixing power.

Agitator Speeds (RPMs):

Low	106
Intermediate	196
High	358

Attachment Speeds (RPMs):

Low	59
Intermediate	110
High	201

Specifications

Standard Equipment: Standard equipment includes a 10 quart #304 series stainless steel bowl, spiral dough hook, stainless steel wire whip, flat beater, stainless steel bowl guard with built in ingredient chute, 15 minute timer, and #12 attachment hub. A sturdy hand lever on the body column raises and lowers the bowl as well as locking in place at the top and bottom positions.

Safety Features: Separate start and emergency stop buttons so operators can shut down the mixer in an emergency situation, and microswitches that automatically shut the mixer down when the guard is opened or the bowl is lowered.

Cord and Plug: 6 ft. flexible three wire cord and ground plug.

Dimensions:

Foot Print = 14.6" x 15.7"
(370 mm x 400 mm)
Overall Length = 21.9" (557 mm)
Overall Width = 16.1" (410 mm)
Overall Height = 24.6" (625 mm)

Shipping Information:

Freight Class: 77.5
Net Weight: 132 lbs. (60 kgs.)
Shipping Weight: 176 lbs. (80 kgs.)
Box Dimensions:
20.5"W x 24.0"D x 32.3"H
(520mm W x 610mm D x 820mm H)
Cartons are affixed to a skid (pallet). The weight and dimensions of this skid are not included above and may vary from shipment to shipment.

Optional Accessories:

XMCA-SS Stainless Steel Meat Grinder (includes S/S cylinder, S/S end ring, S/S worm, S/S pan, stomper, 3/16" plate, and knock knife)

XVSA 9" Vegetable Slicer Assembly (includes an adjustable slicer plate)

XVGA 9" Shredder/Grater Assembly (includes a plate holder and 1 shredder/grater plate)

- XSP332** 3/32" Shredder Plate
- XSP316** 3/16" Shredder Plate
- XSP516** 5/16" Shredder Plate
- XSP12** 1/2" Shredder Plate
- XGP** Grater Plate

XTABLE Stainless Steel Mixer Table with Undershelf

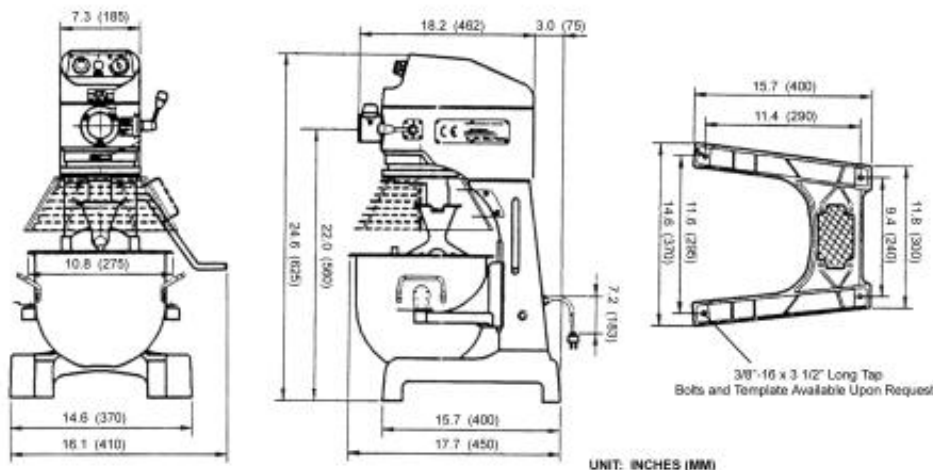

GLOBE FOOD EQUIPMENT COMPANY

www.globeslicers.com

2268 N. Moraine Dr.
Dayton, OH 45439
Phone: 937-299-5493
Phone: 800-347-5423
Fax: 937-299-4147

Printed in U.S.A. 8-2003

Specifications are subject to change without notice.