

Project \_\_\_\_\_

Item # \_\_\_\_\_

Quantity \_\_\_\_\_



GLOBE FOOD EQUIPMENT COMPANY

Automatic Slicers

3850/3975



# 3850/3975 Automatic Slicers

### Models

- 3850 - Two Speed Slicer
- 3975 - Variable Speed Slicer



Made in the U.S.A.

### Standard Features

- Gear driven
- 1/2 HP knife motor, 7 amps
- Exclusive stainless steel construction
- Precision gear thickness adjustment
- Slices tissue thin up to 1 1/4" thick
- Built in antimicrobial protection
- Knife cover interlock
- Signature knife sharpening system
- Touch pad controls
- Full gravity feed - 45° angle
- 3 lb. stainless steel end weight
- 12" hollow ground knife
- Permanently attached knife ring guard
- Auto engage lever
- Lift lever to facilitate cleaning
- Red indicator light
- No voltage release
- 7 foot cord and plug

### Options and Accessories

- Prison package
- High moisture application package (includes stainless steel knife)
- 15" food chute in lieu of 12" chute
- Aluminum food chute in lieu of stainless steel chute
- Stainless steel knife in lieu of carbon steel
- Front mounted end weight assembly in lieu of standard end weight
- Low food fence
- High food fence
- 3" extension legs
- 10 lb. portion control scale
- Vegetable hopper
- Slicer cover

### Standard Warranty

- 2 years parts and 1 year labor plus 15 years on the gears

Approved By: \_\_\_\_\_

Date: \_\_\_\_\_



**GLOBE FOOD EQUIPMENT COMPANY**

[www.globeslicers.com](http://www.globeslicers.com)

P.O. Box 3209  
 Dayton, OH 45401  
 Phone: 937-299-5493  
 Phone: 800-347-5423  
 Fax: 937-299-4147



## Specifications

**Finish:** Exclusive #304 stainless steel base with radiused corners improves sanitation and durability. Other stainless steel parts include the food chute, slicer table, end weight, and knife cover.

**Motors: Knife Motor:** Powerful 1/2 HP, 115-60-1, 7 amps. **Chute Motor:** Two speed DC fractional horsepower 1 amp. Both motors have permanently lubricated sealed ball bearings.

**Knife Drive:** Cross axis helical gear drive design. This positive drive design assures nonslip, trouble free operation.

**Slice Thickness:** Precision gear adjustment holds thickness setting for consistent cuts and allows hot or cold foods to be sliced from tissue thin up to 1 1/4" thick.

**Antimicrobial Protection:** Table adjustment knob, auto engage lever knob, sharpener cover knob, and food chute handle have antimicrobial protection built in.

**Full Gravity Feed:** Full 45° angle feed requires less mechanical pressure. Equipped with a 3 lb. stainless steel end weight to minimize waste and hold product. The end weight swings away for storage behind chute. The food chute handle is ergonomically designed.

**Touch Pad Controls:** Start/stop touch pad controls activate knife motor. **Chute Speed:** Controlled by faster/slower touch pad controls.

**Cord & Plug:** Attached 7 foot flexible 3 wire cord and plug fits a grounded receptacle.

**Lift Lever:** A handle activates two large wheels, lifting the front of the unit to facilitate safe and easy cleaning underneath the slicer.

**Knife Cover Interlock:** Slicer will not operate with knife cover removed.

**Knife Ring Guard:** Permanently mounted knife ring guard protects the non-slicing portion of the knife. Slicer table protects leading edge of knife when completely closed.

**Top Mounted Sharpener:** Sharpener is made of all metal and is permanently mounted on the slicer. A single lever activates the large grinding and honing stones.

**Hollow Ground Knife:** Nominal 12" diameter special hardened steel alloy with stain resistant finish and sanitary hub.

**No Voltage Release:** Prevents inadvertent reactivation of slicer in the event of power or interlock interruption. Operator must restart slicer.

**Capacity:** 6"H x 10 1/2"W or 7 1/2" Dia. (15.2cm x 26.7cm or 19cm)

**Red Indicator Light:** A readily visible light illuminates when knife is rotating.

**Automatic Chute:** Chute travels 40/60 (model 3850) or 20-60 (model 3975) strokes per minute utilizing a separate DC motor with a heavy duty permanently lubricated chain and sprocket drive system. Chute can quickly be engaged or disengaged for manual operation with the auto engage lever.

### Dimensions:

Foot Print = 13.75" x 21.25"  
(34.9 cm x 54 cm)  
Overall Length = 25" (63.5 cm)  
Overall Width = 22" (55.9 cm)  
Overall Height = 24.75" (62.9 cm)  
Freight Class: 77.5  
Net Weight: 153 lbs. (69.4 kgs.)  
Shipping Weight: 165 lbs. (74.7 kgs.)  
Shipping Dimensions:  
28"W x 25"D x 34"H  
(71.1cm W x 63.5cm D x 86.4cm H)

### Factory Installed Options:

**LONGCHUTE** 15" food chute  
**SSK** Stainless steel knife  
**FMEW** Front mounted end weight  
**ALUM** Aluminum food chute  
**MEATROOM** High moisture application package  
**PRISON** Prison package

### Accessories:

**1326** High fence (12" x 3")  
**1047** Low fence (12" x 1 3/8")  
**873-SET** 3" extension legs  
**PS10** 10 lb. Portion control scale  
**699-AS** Vegetable hopper  
**SC-GLOBE** Slicer cover

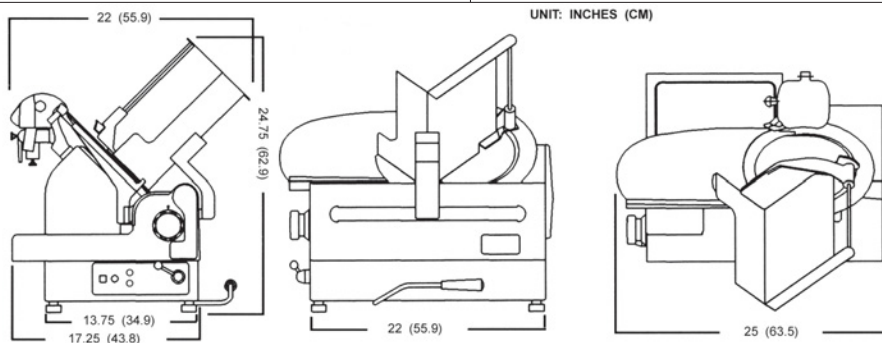

## GLOBE FOOD EQUIPMENT COMPANY

[www.globeslicers.com](http://www.globeslicers.com)

P.O. Box 3209  
Dayton, OH 45401  
Phone: 937-299-5493  
Phone: 800-347-5423  
Fax: 937-299-4147

Printed in U.S.A. 1-2005