



# TRUE FOOD SERVICE EQUIPMENT, INC.

2001 East Terra Lane • P.O. Box 970 • O'Fallon, Missouri 63366  
(636)240-2400 • Fax (636)272-2408 • (800)325-6152 • Intl Fax# (001)636-272-7546  
Parts Dept. (800)424-TRUE • Parts Dept. Fax# (636)272-9471 • www.truemfg.com

Project Name: \_\_\_\_\_

A/A #

Location: \_\_\_\_\_

Item #: \_\_\_\_\_ Qty: \_\_\_\_\_

SIS #

Model #: \_\_\_\_\_

Model:  
**TWT-93**

## Deep Worktop: Solid Door Refrigerator

### TWT-93

- ▶ True's deep worktop units are designed with enduring quality that protects your long term investment.
- ▶ True's deep worktop units feature the combined advantage of convenient worktop prep space with deeper refrigerated storage.
- ▶ Designed using the highest quality materials and components to provide the user with colder product temperatures, lower utility costs, exceptional food safety and the best value in today's food service marketplace.
- ▶ Oversized, environmentally friendly (134A) forced-air refrigeration system holds 33°F to 38°F (.5°C to 3.3°C).
- ▶ All stainless steel front, top and cabinet ends. Matching aluminum finished back. Cabinet top and backsplash are one piece formed construction. Bacteria and food particles can not be trapped underneath as with other two-piece worktop units.
- ▶ NSF approved, white aluminum interior liner. 300 series stainless floor with coved corners.
- ▶ Foamed-in-place, high density polyurethane insulation (CFC free).
- ▶ Heavy duty PVC coated wire shelves.



### ROUGH-IN DATA

Specifications subject to change without notice.  
Chart dimensions rounded up to the nearest 1/8" (millimeters rounded up to next whole number).

Model	Doors	Capacity (Cu. Ft.) (liters)	Shelves	Cabinet Dimensions (inches) (mm)			HP	Voltage	Amps	NEMA Config.	Cord Length (total ft.) (total m)	Crated Weight (lbs.) (kg)
				L	D <sup>†</sup>	H*						
TWT-93	3	30.9 875	6	93 <sup>1</sup> / <sub>4</sub>	32 <sup>3</sup> / <sub>8</sub>	33 <sup>3</sup> / <sub>8</sub>	1/2	115/60/1	9.7	5-15P ▲	7 2.13	535 243
				2369	823	848	1/2	230-240/50/1	4.2			

† Depth does not include 1" (26 mm) for rear bumpers and 1/4" (7 mm) for front bumper.

▲ Plug type varies by country.

\* Height does not include 6 1/4" (159 mm) for castors or 6" (153 mm) for optional legs.

	<b>APPROVALS:</b>  	<b>AVAILABLE AT:</b>  
1/08	Printed in U.S.A.	

Model:  
**TWT-93**

**Deep Worktop:**  
*Solid Door Refrigerator*



**STANDARD FEATURES**

**DESIGN**

- True's commitment to using the highest quality materials and oversized refrigeration systems provides the user with colder product temperatures, lower utility costs, exceptional food safety and the best value in today's food service marketplace.

**REFRIGERATION SYSTEM**

- Factory engineered, self-contained, capillary tube system using environmentally friendly (CFC free) 134A refrigerant.
- Oversized, factory balanced refrigeration system with guided airflow to provide uniform product temperatures.
- Extra large evaporator coil balanced with higher horsepower compressor and large condenser; maintains cabinet temperatures of 33°F to 38°F (.5°C to 3.3°C) for the best in food preservation.
- Sealed, cast iron, self-lubricating evaporator fan motor(s) and larger fan blades give True worktop units a more efficient low velocity, high volume airflow design. This unique design ensures faster temperature recovery and shorter run times in the busiest of foodservice environments.
- Condensing unit is accessed from behind front grill; slides out for easy maintenance.

**CABINET CONSTRUCTION**

- Exterior - stainless steel front, top and ends. Matching aluminum finished back. Top and backsplash are one piece formed construction.
- Interior - attractive, NSF approved, white aluminum liner. 300 series stainless floor with coved corners.

- Insulation - entire cabinet structure and solid doors are foamed-in-place using high density, CFC free, polyurethane insulation.
- 5" (127 mm) diameter stem castors - locks provided on front set. 36" (915 mm) work surface height.

**DOORS**

- Stainless steel exterior with white aluminum liner to match cabinet interior.
- Each door fitted with 12" (305 mm) long recessed handle that is foamed-in-place with a sheet metal interlock to ensure permanent attachment.
- Doors swing within cabinet dimensions.
- Magnetic door gaskets of one piece construction, removable without tools for ease of cleaning.

**SHELVING**

- Six (6) adjustable, heavy duty PVC coated wire shelves. Two (2) left and two (2) right door shelf dimensions are 23<sup>5</sup>/<sub>8</sub>" L x 28" D (601 mm x 712 mm). Two (2) center door shelf dimensions are 25<sup>1</sup>/<sub>2</sub>" L x 28" D (648 mm x 712 mm). Four (4) chrome plated shelf clips included per shelf.
- Shelf support pilasters made of same material as cabinet interior; shelves are adjustable on 1/2" (13 mm) increments.

**MODEL FEATURES**

- Evaporator is epoxy coated to eliminate the potential of corrosion.
- NSF-7 compliant for open food product.

**ELECTRICAL**

- Unit completely pre-wired at factory and ready for final connection to a 115/60/1 phase - 15 amp dedicated outlet. Cord and plug set included.



115/60/1  
NEMA-5-15R

**OPTIONAL FEATURES/ACCESSORIES**

- Upcharge and lead times may apply.
- 230-240V / 50 Hz.
  - 6" (153 mm) standard legs.
  - 6" (153 mm) seismic/flanged legs.
  - 2<sup>1</sup>/<sub>2</sub>" (64 mm) diameter castors.
  - 3" (85 mm) diameter castors.
  - Single utility shelf.
  - Double utility shelf.
  - 30" (762 mm) deep, 1/2" (13 mm) thick, white polyethylene cutting board. Requires "L" brackets.
  - 30" (762 mm) deep, 1/2" (13 mm) thick, composite cutting board. Requires "L" brackets.
  - Additional shelves.
  - Heavy duty, 16 gauge tops.
  - Heavy duty package - 16 gauge tops, 20 gauge door, sides and back with stainless interior.
  - Half bun tray racks. Holds 18" L x 26" D (458 mm x 661 mm) sheet pans (sold separately).
  - Exterior round digital thermometer (factory installed).
  - Remote cabinets (condensing unit supplied by others; system comes standard with 404A expansion valve and requires R404A refrigerant), consult factory technical service department for BTU information.

**PLAN VIEW**

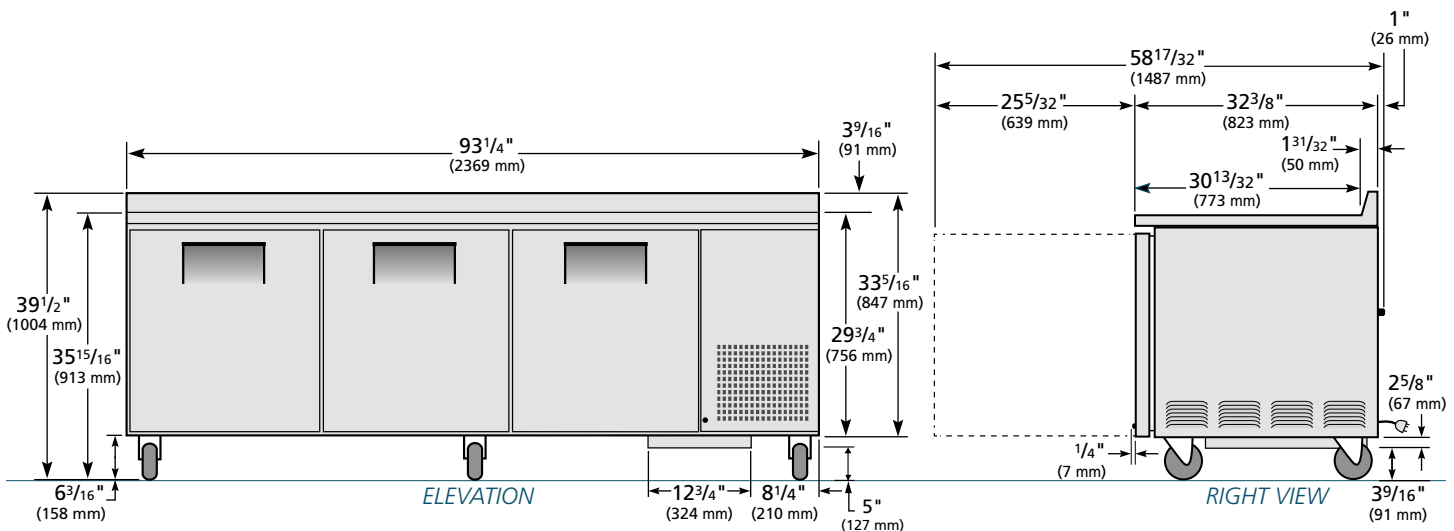

**WARRANTY**  
One year warranty on all parts and labor and an additional 4 year warranty on compressor. (U.S.A. only)

METRIC DIMENSIONS ROUNDED UP TO THE NEAREST WHOLE MILLIMETER  
SPECIFICATIONS SUBJECT TO CHANGE WITHOUT NOTICE



Model	Elevation	Right	Plan	3D
TWT-93	TFPY23E	TFPY32S	TFPY23P	TFPY233

**TRUE FOOD SERVICE EQUIPMENT**