



TRUE FOOD SERVICE EQUIPMENT, INC.

2001 East Terra Lane • P.O. Box 970 • O'Fallon, Missouri 63366
 (636)240-2400 • Fax (636)272-2408 • (800)325-6152 • Intl Fax# (001)636-272-7546
 Parts Dept. (800)424-TRUE • Parts Dept. Fax# (636)272-9471 • www.truemfg.com

Project Name: _____

A/A #

Location: _____

Item #: _____ Qty: _____

SIS #

Model #: _____

Model:
TS-49G

TS Series:

Reach-In 300 Series Stainless Steel Glass Door Refrigerator



Photo shown with optional shelving.

TS-49G

- ▶ True's TS series is the choice for the exclusive 300 series stainless steel commercial application.
- ▶ Designed using the highest quality materials and components to provide the user with colder product temperatures, lower utility costs, exceptional food safety and the best value in today's food service marketplace.
- ▶ Oversized, factory balanced, refrigeration system holds 33°F to 38°F (.5°C to 3.3°C) for the best in food preservation.
- ▶ 300 series stainless steel interior and exterior front & sides with matching aluminum back. The very finest stainless with higher tensile strength for fewer dents and scratches.
- ▶ Energy efficient, "Low-E", double pane thermal glass doors.
- ▶ Patented integrated door light (IDL) system for high product visibility.
- ▶ Adjustable, heavy duty PVC coated shelves.
- ▶ Positive seal self-closing doors. Lifetime guaranteed door hinges and torsion type closure system.

Bottom mounted units feature:

- ▶ "No stoop" lower shelf.
- ▶ Storage on top of cabinet.
- ▶ Compressor performs in coolest, most grease free area of kitchen.
- ▶ Easily accessible condenser coil for cleaning.

ROUGH-IN DATA

Specifications subject to change without notice.
 Chart dimensions rounded up to the nearest 1/8" (millimeters rounded up to next whole number).

Model	Doors	Capacity (Cu. Ft.) (liters)	Shelves	Cabinet Dimensions (inches) (mm)			HP	Voltage	Amps	NEMA Config.	Cord Length (total ft.) (total m)	Crated Weight (lbs.) (kg)
				L	D†	H*						
TS-49G	2	49 1388	6	54 1/8 1375	29 3/4 756	78 3/8 1991	1/2 1/2	115/60/1 230-240/50/1	9.1 5.4	5-15P ▲	9 2.74	515 234

† Depth does not include 1 3/8" (35 mm) for door handles.

▲ Plug type varies by country.

* Height does not include 5" (127 mm) for castors or 6" (153 mm) for optional legs.

	APPROVALS:	AVAILABLE AT:
9/07 Printed in U.S.A.		

Model:
TS-49G

TS Series:
Reach-In 300 Series Stainless Steel
Glass Door Refrigerator



STANDARD FEATURES

DESIGN

- True's glass door reach-in's are designed with enduring quality that protects your long term investment.
- True's commitment to using the highest quality materials and oversized refrigeration systems provides the user with colder product temperatures, lower utility costs, exceptional food safety and the best value in today's food service marketplace.

REFRIGERATION SYSTEM

- Factory engineered, self-contained, capillary tube system using environmentally friendly (CFC free) 134A refrigerant.
- Extra large evaporator coil balanced with higher horsepower compressor and large condenser; maintains 33°F to 38°F (.5°C to 3.3°C) for the best in food preservation.
- Sealed, cast iron, self-lubricating evaporator fan motor(s) and larger fan blades give True reach-in's a more efficient, low velocity, high volume airflow design. This unique design ensures faster temperature recovery and shorter run times in the busiest of foodservice environments.
- Bottom mounted condensing unit positioned for easy maintenance. Compressor runs in coolest and most grease free area of the kitchen. Allows for storage area on top of unit.

CABINET CONSTRUCTION

- Exterior - 300 series stainless front and sides. Matching aluminum back.
- Interior - 300 series stainless steel liner and floor.

- Insulation - entire cabinet structure and solid doors are foamed-in-place using high density, CFC free, polyurethane insulation.
- Welded, heavy duty galvanized frame rail dipped in rust inhibiting enamel paint for corrosion protection inside and out.
- Frame rail fitted with 4" (102 mm) diameter stem castors - locks provided on front set.

DOORS

- "Low-E", double pane thermal glass assemblies with extruded aluminum frames. Door locks standard.
- Each door fitted with 15" (381 mm) long extruded aluminum handle.
- Positive seal self-closing doors. Lifetime guaranteed door hinges and torsion type closure system.
- Magnetic door gaskets of one piece construction, removable without tools for ease of cleaning.

SHELVING

- Six (6) adjustable, heavy duty PVC coated wire shelves 24⁹/₁₆" L x 23³/₈" D (624 mm x 569 mm). Four (4) chrome plated shelf clips included per shelf.
- Aluminum shelf support pilasters. Shelves are adjustable on 1/2" (13 mm) increments.

LIGHTING

- Fluorescent interior lighting. Each door utilizes full-length, patented, integrated door light (IDL) system. Safety shielded.

MODEL FEATURES

- Evaporator is epoxy coated to eliminate the potential of corrosion.

- Exterior solar temperature display.
- NSF-7 compliant for open food product.

ELECTRICAL

- Unit completely pre-wired at factory and ready for final connection to a 115/60/1 phase - 15 amp dedicated outlet. Cord and plug set included.



115/60/1
NEMA-5-15R

OPTIONAL FEATURES/ACCESSORIES

Upcharge and lead times may apply.

- 230 - 240V / 50 Hz.
- 6" (153 mm) standard legs.
- 6" (153 mm) seismic/flanged legs.
- Alternate door hinging (factory installed).
- Additional shelves.
- Half door bun tray racks. Each holds up to eleven 18" L x 26" D (458 mm x 661 mm) sheet pans (sold separately).
- Full door bun tray racks. Each holds up to twenty-two 18" L x 26" D (458 mm x 661 mm) sheet pans (sold separately).
- Remote cabinets (condensing unit supplied by others; system comes standard with 404A expansion valve and requires R404A refrigerant). Consult factory technical service department for BTU information.

PLAN VIEW

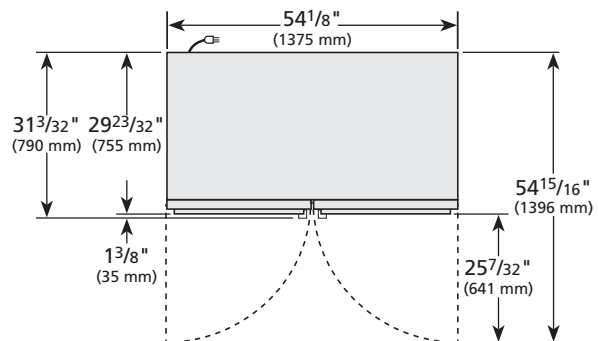
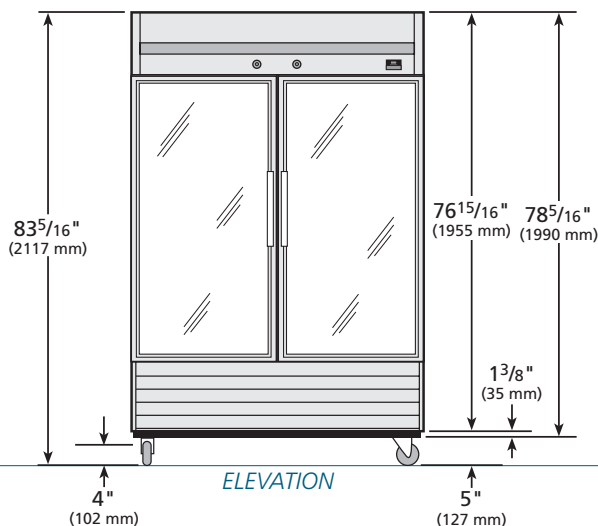

ELEVATION

PLAN VIEW

WARRANTY

One year warranty on all parts and labor and an additional 4 year warranty on compressor. (U.S.A. only)

METRIC DIMENSIONS ROUNDED UP TO THE NEAREST WHOLE MILLIMETER
SPECIFICATIONS SUBJECT TO CHANGE WITHOUT NOTICE



Model	Elevation	Right	Plan	3D
TS-49G	TFEY07E	TFEY06S	TFEY07P	TFEY073

TRUE FOOD SERVICE EQUIPMENT

2001 East Terra Lane • P.O. Box 970 • O'Fallon, Missouri 63366 • (636)240-2400 • Fax (636)272-2408 • (800)325-6152 • Intl. Fax# (001)636-272-7546 • www.truemfg.com