



TRUE FOOD SERVICE EQUIPMENT, INC.

2001 East Terra Lane • P.O. Box 970 • O'Fallon, Missouri 63366
(636)240-2400 • Fax (636)272-2408 • (800)325-6152 • Intl Fax# (001)636-272-7546
Parts Dept. (800)424-TRUE • Parts Dept. Fax# (636)272-9471 • www.truemfg.com

Project Name: _____

A/A #

Location: _____

Item #: _____ Qty: _____

SIS #

Model #: _____

Model:
TRCB-48

Chef Base:
Drawered Refrigerator

TRCB-48

- ▶ True's refrigerated chef bases are designed with enduring quality that protects your long term investment.
- ▶ Designed using the highest quality materials and components to provide the user with colder product temperatures, lower utility costs, exceptional food safety and the best value in today's food service marketplace.
- ▶ Oversized, environmentally friendly (134A) forced-air refrigeration system holds 33°F to 38°F (.5°C to 3.3°C).
- ▶ Cabinet top is one piece, heavy duty reinforced 300 series stainless steel. Drip resistant "V" edge protects against spills. Supports up to 717 lbs. (326 kg).
- ▶ All stainless steel front, top and sides. Matching aluminum finished back.
- ▶ Each drawer accommodates two (2) full size 12" L x 20" W x 4" D (305 mm x 508 mm x 102 mm) food pans (sold separately).
- ▶ Heavy-duty stainless steel drawer slides and rollers. Removable without tools for easy cleaning.
- ▶ Foamed-in-place, high density polyurethane insulation (CFC free).



ROUGH-IN DATA

Specifications subject to change without notice.

Chart dimensions rounded up to the nearest 1/8" (millimeters rounded up to next whole number).

Model	Drawers	Cabinet Dimensions (inches) (mm)			HP	Voltage	Amps	NEMA Config.	Cord Length (total ft.) (total m)	Crated Weight (lbs.) (kg)
		L	D†	H*						
TRCB-48	2	48 ^{3/8} 1229	32 ^{1/8} 816	20 ^{3/8} 518	1/5	115/60/1	5.4	5-15P	7 2.1	315 143

† Depth does not include 1" (26 mm) for bumpers.

* Height does not include 5" (127 mm) for castors or 6" (153 mm) for optional legs.



8/07

Printed in U.S.A.

APPROVALS:

AVAILABLE AT:

Model:
TRCB-48

Chef Base:
Drawered Refrigerator



STANDARD FEATURES

DESIGN

- True's commitment to using the highest quality materials and oversized refrigeration systems provides the user with colder product temperatures, lower utility costs, exceptional food safety and the best value in today's food service marketplace.

REFRIGERATION SYSTEM

- Factory engineered, self-contained, capillary tube system using environmentally friendly (CFC free) 134A refrigerant.
- Oversized, factory balanced refrigeration system with guided airflow to provide uniform product temperatures.
- Extra large evaporator coil balanced with higher horsepower compressor and large condenser; maintains cabinet temperatures of 33°F to 38°F (.5°C to 3.3°C) for the best in food preservation.
- Sealed, cast iron, self-lubricating evaporator fan motor(s) and larger fan blades give True chef base units a more efficient, low velocity, high volume airflow design. This unique design ensures faster temperature recovery and shorter run times in the busiest of foodservice environments.
- Condensing unit accessed from behind side grill; slides out for easy maintenance.

CABINET CONSTRUCTION

- Exterior - stainless steel front, top and sides. Matching aluminum finished back.
- Interior - attractive, NSF approved, white aluminum liner. 300 series stainless steel floor with coved corners.

- Insulation - entire cabinet structure and drawer facings are foamed-in-place using high density, CFC free, polyurethane insulation.
- 4" (102 mm) diameter plate castors - locks provided on front set.
- Cabinet top is one piece, heavy duty reinforced 300 series stainless steel. Drip resistant "V" edge protects against spills. Supports up to 717 lbs. (326 kg).

DRAWERS

- Stainless steel exterior drawer facings and liners. Stainless steel drawer frames.
- Each drawer fitted with 12" (305 mm) long recessed handle that is foamed-in-place with a sheet metal interlock to ensure permanent attachment.
- Heavy-duty stainless steel drawer slides and rollers. Removable without tools for easy cleaning.
- Magnetic drawer gaskets of one piece construction, removable without tools for ease of cleaning.

PAN CAPACITY

- Each drawer accommodates two (2) full size 12" L x 20" W x 4" D (305 mm x 508 mm x 102 mm) food pans (sold separately).
- Drawers support a wide variety of incremental pan size configurations; each drawer standard with one (1) full length removable divider bar.

MODEL FEATURES

- Evaporator is epoxy coated to eliminate the potential of corrosion.
- Exterior digital temperature display.
- NSF-7 compliant for open food product.

ELECTRICAL

- Unit completely pre-wired at factory and ready for final connection to a 115/60/1 phase, 15 amp dedicated outlet. Cord and plug set included.



115/60/1
NEMA-5-15R

RECOMMENDED OPERATION CONDITIONS

- Counter-top cooking equipment should be used in conjunction with the manufacturer supplied legs. Minimum clearance of 4" (102 mm) required between bottom of cooking equipment heating element and the TRCB top. Failure to provide clearance voids cabinet warranty.

OPTIONAL FEATURES/ACCESSORIES

Upcharge and lead times may apply.

- 6" (153 mm) standard legs (1 set of 4 leg mounting plates required).
- 6" (153 mm) seismic/flanged legs (1 set of 4 leg mounting plates required).
- Heavy duty 16 gauge top.
- Flat top (no marine edge).
- Additional size drawer divider bars.
- Remote cabinets (condensing unit supplied by others; system comes standard with 404A expansion valve and requires R404A refrigerant). Consult factory technical service department for BTU information.

PLAN VIEW

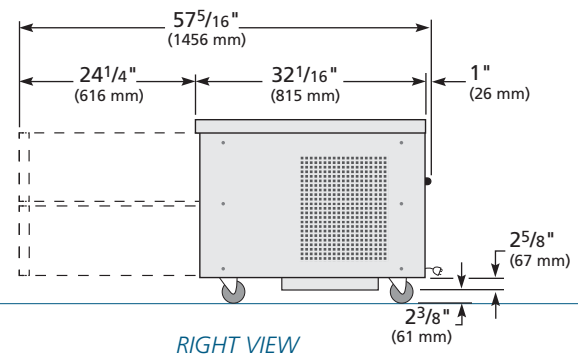
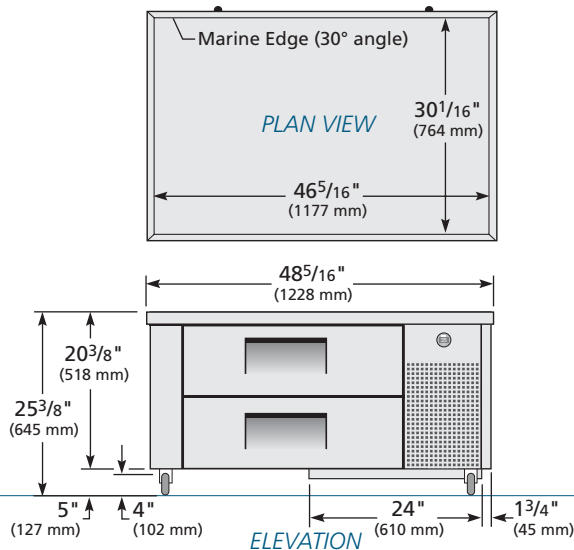

WARRANTY

One year warranty on all parts and labor and an additional 4 year warranty on compressor. (U.S.A. only)

METRIC DIMENSIONS ROUNDED UP TO THE NEAREST WHOLE MILLIMETER

SPECIFICATIONS SUBJECT TO CHANGE WITHOUT NOTICE



Model	Elevation	Right	Plan	3D
TRCB-48				

TRUE FOOD SERVICE EQUIPMENT

2001 East Terra Lane • P.O. Box 970 • O'Fallon, Missouri 63366 • (636)240-2400 • Fax (636)272-2408 • (800)325-6152 • Intl. Fax# (001)636-272-7546 • www.truemfg.com