



# TRUE FOOD SERVICE EQUIPMENT, INC.

2001 East Terra Lane • P.O. Box 970 • O'Fallon, Missouri 63366  
(636)240-2400 • Fax (636)272-2408 • (800)325-6152 • Intl Fax# (001)636-272-7546  
Parts Dept. (800)424-TRUE • Parts Dept. Fax# (636)272-9471 • www.truefmfg.com

Project Name: \_\_\_\_\_

A/A #

Location: \_\_\_\_\_

Item #: \_\_\_\_\_ Qty: \_\_\_\_\_

SIS #

Model #: \_\_\_\_\_

Model:  
**TR3R-3S**

**TR Series:**  
*Reach-In Solid Door Refrigerator*

## TR3R-3S



- ▶ Designed using the highest quality materials and components to provide the user with colder product temperatures, lower utility costs and exceptional food safety.
- ▶ Oversized, factory balanced, refrigeration system holds 33°F to 38°F (.5°C to 3.3°C) for the best in food preservation.
- ▶ 300 series stainless steel exterior and interior. The very finest stainless with higher tensile strength for fewer dents and scratches.
- ▶ Equipped with one (1) interior kit option per section, factory installed. Four (4) different interior kits available.
- ▶ Positive seal self-closing doors with 120° stay open feature. Lifetime guaranteed door hinges.
- ▶ Lifetime guaranteed recessed door handles.
- ▶ Entire cabinet structure and solid doors are foamed-in-place using high density, CFC free, polyurethane insulation.

### ROUGH-IN DATA

Specifications subject to change without notice.  
Chart dimensions rounded up to the nearest 1/8" (millimeters rounded up to next whole number).

Model	Doors	Capacity (Cu. Ft.) (liters)	Cabinet Dimensions (inches) (mm)			HP	Voltage	Amps	NEMA Config.	Cord Length (total ft.) (total m)	Crated Weight (lbs.) (kg)
			L	D	H*						
TR3R-3S	3	85 2407	76 <sup>1</sup> / <sub>2</sub> 1944	34 <sup>5</sup> / <sub>8</sub> 880	78 <sup>1</sup> / <sub>4</sub> 1988	1/2 3/4	115/60/1 230-240/50/1	11.8 7.8	5-15P ▲	9 2.74	770 350

\* Height does not include 5" (127 mm) for castors, 6" (153 mm) for optional legs, and 1" (26 mm) for system mechanical components.

▲ Plug type varies by country.



APPROVALS:

AVAILABLE AT:

Model:  
**TR3R-3S**

**TR Series:**  
Reach-In Solid Door Refrigerator



## STANDARD FEATURES

### DESIGN

- True's solid door reach-in's are designed with enduring quality that protects your long term investment.
- Designed using the highest quality materials and components to provide the user with colder product temperatures, lower utility costs and exceptional food safety.

### REFRIGERATION SYSTEM

- Factory engineered, self-contained, capillary tube system using environmentally friendly (CFC free) 134A refrigerant.
- Extra large evaporator coil balanced with higher horsepower compressor and large condenser maintains cabinet temperatures of 33°F to 38°F (.5°C to 3.3°C) for the best in food preservation.
- Sealed, cast iron, self-lubricating evaporator fan motor(s) and larger fan blades give True reach-in's a more efficient low velocity, high volume airflow design. This unique design ensures faster temperature recovery and shorter run times in the busiest of foodservice environments.
- Top mounted refrigeration system with evaporator positioned out of food zone to maximize capacity.
- Hot gas condensate for energy efficiency.

### CABINET CONSTRUCTION

- Exterior - 300 series stainless steel doors, front, sides, back and bottom.
- Interior - 300 series stainless steel liner and floor.
- Insulation - entire cabinet structure and solid doors are foamed-in-place using high density, CFC free, polyurethane insulation.
- Welded, heavy duty galvanized frame rail dipped in rust inhibiting enamel paint for corrosion protection inside and out.
- Frame rail fitted with 4" (102 mm) diameter stem castors - locks provided on front set.

### DOORS

- 300 series stainless steel exterior and liners. Doors open within cabinet dimensions.
- Door locks standard.
- Lifetime guaranteed recessed door handles. Each door fitted with 12" (305 mm) long recessed handle that is foamed-in-place with a sheet metal interlock to ensure permanent attachment.
- Positive seal self-closing doors with 120° stay open feature (center door has 90° stay open feature). Lifetime guaranteed door hinges.
- Magnetic door gaskets of one piece construction, removable without tools for ease of cleaning.

### SHELVING

- One (1) factory installed interior kit option per section. Four (4) different interior kits available (see Kit Options). Pilasters and tray slides are factory installed at no charge.

### LIGHTING

- Incandescent interior lighting, safety shielded.

### MODEL FEATURES

- Exterior digital temperature display, available with either °F or °C.
- Evaporator epoxy coated to eliminate the potential of corrosion.
- NSF-7 compliant for open food product.

### ELECTRICAL

- Unit completely pre-wired at factory and ready for final connection to a 115/60/1 phase - 15 amp dedicated outlet. Cord and plug set included.



115/60/1  
NEMA-5-15R

### OPTIONAL FEATURES/ACCESSORIES

Upcharge and lead times may apply.

- 230-240V / 50 Hz.
- 6" (153 mm) standard legs.
- 6" (153 mm) seismic/flanged legs.
- 6" (153 mm) stainless steel legs.
- Stainless steel rail skirt for use with legs (field installed).
- Metal door handles (factory installed).
- Electronic temperature control (factory installed).
- Correctional facilities options.
- Curb mountable units.
- Remote cabinets (condensing units supplied by others; system comes standard with 404A expansion valve and requires R404A refrigerant). Consult factory technical service department for BTU information.

### KIT OPTIONS

- Kit #1: Nine (9) sets of #1 type tray slides and pilasters (factory installed), bottom support of one (1) 18" L x 26" D (458 mm x 661 mm) pan or two (2) 14" L x 18" D (356 mm x 458 mm) pans.
- Kit #2: One (1) set half-section #2 steel rod tray slides and pilasters (factory installed), rim support of one (1) 18" L x 26" D (458 mm x 661 mm) pan.
- Kit #3: Six (6) sets of universal type tray slides and pilasters (factory installed), bottom support of one (1) 18" L x 26" D (458 mm x 661 mm) pans or two (2) 14" L x 18" D (356 mm x 458 mm) pans.
- Kit #4: Three (3) chrome shelves. Right and left door shelf dimensions are 23 1/2" L x 27 3/4" D (597 mm x 705 mm). Center door shelf dimensions are 25" L x 27 3/4" D (635 mm x 705 mm). Four (4) shelf supports included per shelf (factory installed); adjustable on 6" (153 mm) increments. Optional wall mounted shelf support pilasters (factory installed) with four (4) shelf clips per shelf available; adjustable on 1/2" (13 mm) increments.
- Additional kit option components available individually. Upcharge applies.

## PLAN VIEW

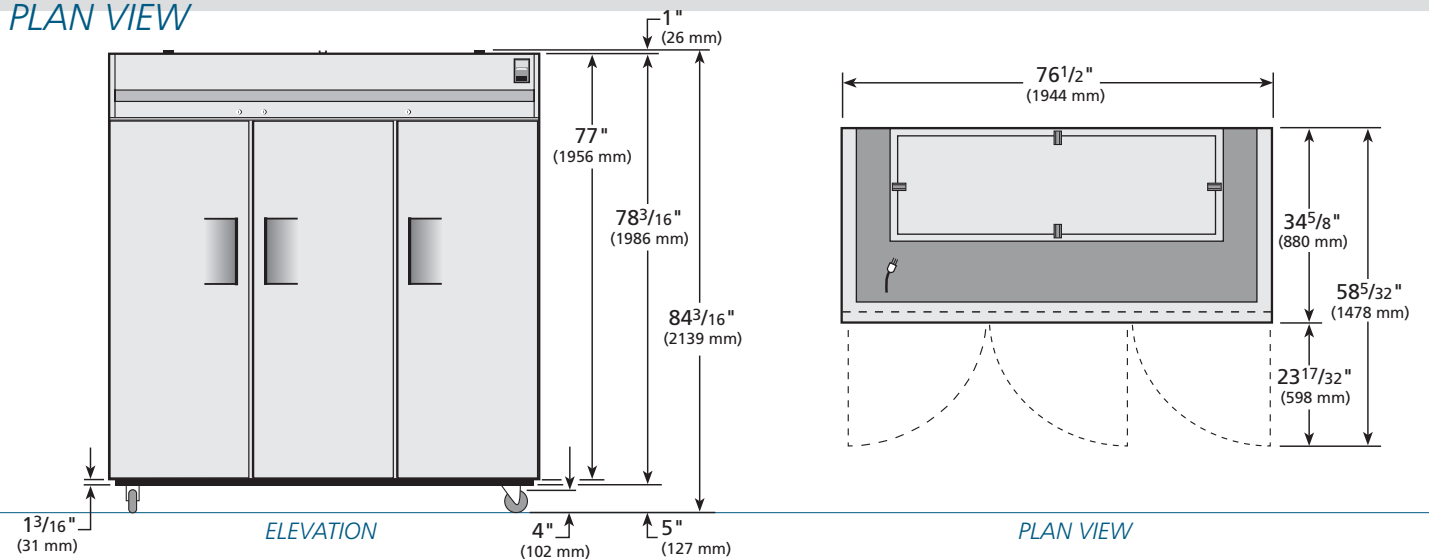

### WARRANTY

One year warranty on all parts and labor and an additional 4 year warranty on compressor. (U.S.A. only)

METRIC DIMENSIONS ROUNDED UP TO THE NEAREST WHOLE MILLIMETER

SPECIFICATIONS SUBJECT TO CHANGE WITHOUT NOTICE



Model	Elevation	Right	Plan	3D
TR3R-3S	TFQY57E	TFQY157S	TFQY157P	TFQY1573

## TRUE FOOD SERVICE EQUIPMENT

2001 East Terra Lane • P.O. Box 970 • O'Fallon, Missouri 63366 • (636)240-2400 • Fax (636)272-2408 • (800)325-6152 • Intl. Fax# (001)636-272-7546 • www.truemfg.com