



**TRUE FOOD SERVICE EQUIPMENT, INC.**

2001 East Terra Lane • P.O. Box 970 • O'Fallon, Missouri 63366  
 (636)240-2400 • Fax (636)272-2408 • (800)325-6152 • Intl Fax# (001)636-272-7546  
 Parts Dept. (800)424-TRUE • Parts Dept. Fax# (636)272-9471 • www.truemfg.com

Project Name: \_\_\_\_\_

A/A #

Location: \_\_\_\_\_

Item #: \_\_\_\_\_ Qty: \_\_\_\_\_

SIS #

Model #: \_\_\_\_\_

Model:  
**TR2RRI-2S**

**TR Series:**  
*Roll-in Solid Door Refrigerator*



**TR2RRI-2S**

- ▶ Designed using the highest quality materials and components to provide the user with colder product temperatures, lower utility costs and exceptional food safety.
- ▶ Oversized, factory balanced, refrigeration system holds 33°F to 38°F (.5°C to 3.3°C) for the best in food preservation.
- ▶ 300 series stainless steel exterior and interior. The very finest stainless with higher tensile strength for fewer dents and scratches.
- ▶ Designed to accept roll-in racks (inboard castors) with maximum dimensions of 27" L x 29" D x 66" H (686 mm x 737 mm x 1677 mm). One (1) heavy gauge stainless steel ramp standard per door.
- ▶ Three (3) lifetime guaranteed, cam-lift hinges per door. Full 180° open capability with a stay open feature at 120°.
- ▶ Lifetime guaranteed recessed door handles.
- ▶ Entire cabinet structure and solid doors are foamed-in-place using high density, CFC free, polyurethane insulation.

**ROUGH-IN DATA**

Specifications subject to change without notice.

Chart dimensions rounded up to the nearest 1/8" (millimeters rounded up to next whole number).

Model	Doors	Capacity (Cu. Ft.) (liters)	Cabinet Dimensions (inches) (mm)			HP	Voltage	Amps	NEMA Config.	Cord Length (total ft.) (total m)	Crated Weight (lbs.) (kg)
			L	D <sup>†</sup>	H*						
TR2RRI-2S	2	75 2124	68 1728	34 <sup>1</sup> / <sub>2</sub> 877	83 <sup>3</sup> / <sub>4</sub> 2128	1/2	115/60/1	11.8	5-15P	9 2.74	706 321

† Depth does not include 4<sup>1</sup>/<sub>4</sub>" (108 mm) for ramps.

\* Height does not include 1" (26 mm) for system mechanical components.

1/08 Printed in U.S.A.

**APPROVALS:**

**AVAILABLE AT:**

Model:  
**TR2RRI-2S**

**TR Series:**  
Roll-in Solid Door Refrigerator



## STANDARD FEATURES

### DESIGN

- True's solid door roll-in's are designed with enduring quality that protects your long term investment.
- Designed using the highest quality materials and components to provide the user with colder product temperatures, lower utility costs and exceptional food safety.

### REFRIGERATION SYSTEM

- Factory engineered, self-contained, capillary tube system using environmentally friendly (CFC free) 134A refrigerant.
- Extra large evaporator coil balanced with higher horsepower compressor and large condenser maintains cabinet temperatures of 33°F to 38°F (.5°C to 3.3°C) for the best in food preservation.
- Sealed, cast iron, self-lubricating evaporator fan motor(s) and larger fan blades give True roll-in's a more efficient low velocity, high volume airflow design. This unique design ensures faster temperature recovery and shorter run times in the busiest of foodservice environments.
- Top mounted refrigeration system with evaporator positioned out of food zone to maximize capacity.
- Hot gas condensate for energy efficiency.

### CABINET CONSTRUCTION

- Exterior - 300 series stainless steel doors, front, sides, back and bottom.
- Interior - 300 series stainless steel liner and floor.

- Insulation - entire cabinet structure and solid doors are foamed-in-place using high density, CFC free, polyurethane insulation.
- One (1) heavy gauge stainless steel ramp per door.
- Designed to accept roll-in racks (inboard castors) with maximum dimensions of 27" L x 29" D x 66" H (686 mm x 737 mm x 1677 mm).

### DOORS

- 300 series stainless steel exterior and liners. Doors open within cabinet dimension.
- Door locks standard.
- Lifetime guaranteed recessed door handles. Each door fitted with 12" (305 mm) long recessed handle that is foamed-in-place with a sheet metal interlock to ensure permanent attachment.
- Wiper gaskets for positive seal, reversible.
- Three (3) lifetime guaranteed, cam-lift hinges per door. Full 180° open capability with a stay open feature at 120°.
- Magnetic door gaskets of one piece construction, removable without tools for ease of cleaning.
- Doors are field reversible.

### LIGHTING

- Incandescent interior lighting, safety shielded.

### MODEL FEATURES

- Exterior, digital temperature display, available with either °F or °C display.
- Evaporator is epoxy coated to eliminate the potential of corrosion.
- Interior bumpers protect cabinet walls from abuse caused by roll-in carts.
- NSF-7 compliant for open food product.

### ELECTRICAL

- Unit completely pre-wired at factory and ready for final connection to a 115/60/1 phase - 15 amp dedicated outlet. Cord and plug set included.



115/60/1  
NEMA-5-15R

### OPTIONAL FEATURES/ACCESSORIES

Upcharge and lead times may apply.

- Metal door handles (factory installed).
- Electronic temperature control (factory installed).
- Correctional facilities options.
- Remote cabinets (condensing unit supplied by others; system comes standard with 404A expansion valve and requires R404A refrigerant). Consult factory technical service department for BTU information.

## PLAN VIEW

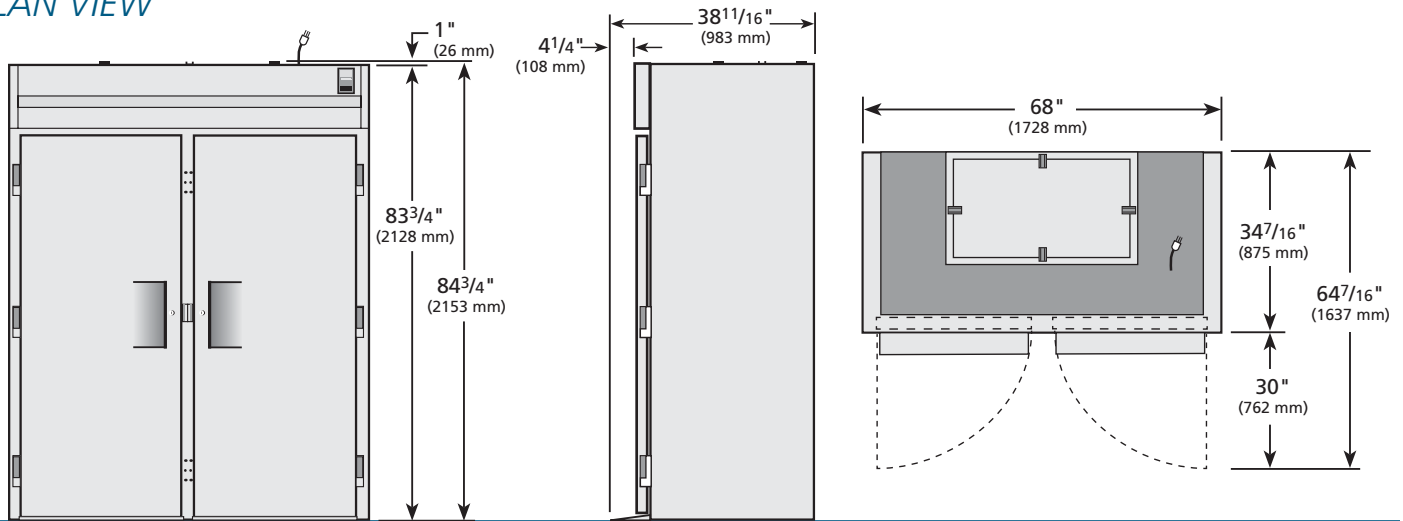

ELEVATION

RIGHT VIEW

PLAN VIEW

### WARRANTY

One year warranty on all parts and labor and an additional 4 year warranty on compressor. (U.S.A. only)

METRIC DIMENSIONS ROUNDED UP TO THE NEAREST WHOLE MILLIMETER

SPECIFICATIONS SUBJECT TO CHANGE WITHOUT NOTICE



Model	Elevation	Right	Plan	3D
TR2RRI-2S	TFQY55E	TFQY51S	TFQY55P	TFQX553

## TRUE FOOD SERVICE EQUIPMENT

2001 East Terra Lane • P.O. Box 970 • O'Fallon, Missouri 63366 • (636)240-2400 • Fax (636)272-2408 • (800)325-6152 • Intl. Fax# (001)636-272-7546 • www.truemfg.com