



TRUE FOOD SERVICE EQUIPMENT, INC.

2001 East Terra Lane • P.O. Box 970 • O'Fallon, Missouri 63366
 (636)240-2400 • Fax (636)272-2408 • (800)325-6152 • Intl Fax# (001)636-272-7546
 Parts Dept. (800)424-TRUE • Parts Dept. Fax# (636)272-9471 • www.truemfg.com

Project Name: _____

Location: _____

Item #: _____ Qty: _____

Model #: _____

A/A #

SIS #

Model:
TR2DT-4HS

TR Series:

Reach-In Solid Half Door Dual Temperature Refrigerator / Freezer



TR2DT-4HS

- ▶ Designed using the highest quality materials and components to provide the user with colder product temperatures, lower utility costs and exceptional food safety.
- ▶ Oversized, factory balanced, refrigeration systems. Left section refrigerator holds 33°F to 38°F (.5°C to 3.3°C). Right section freezer holds -10°F (-23.3°C).
- ▶ 300 series stainless steel exterior and interior. The very finest stainless with higher tensile strength for fewer dents and scratches.
- ▶ Equipped with one (1) interior kit option per section, factory installed. Four (4) different interior kits available.
- ▶ Positive seal self-closing doors with 120° stay open feature. Lifetime guaranteed door hinges.
- ▶ Lifetime guaranteed recessed door handles.
- ▶ Entire cabinet structure and solid doors are foamed-in-place using high density, CFC free, polyurethane insulation.

ROUGH-IN DATA

Specifications subject to change without notice.

Chart dimensions rounded up to the nearest 1/8" (millimeters rounded up to next whole number).

| Model | Doors | Capacity (Cu. Ft.) (liters) | | Cabinet Dimensions (inches) (mm) | | | HP | | Voltage | Amps | NEMA Config. | Cord Length (total ft.) (total m) | Crated Weight (lbs.) (kg) |
|-----------|-------|-----------------------------|-----------|--|---------------------------------------|--|------|------|------------------|------|--------------|-----------------------------------|---------------------------|
| | | Ref. | Frz. | L | D† | H* | Ref. | Frz. | | | | | |
| TR2DT-4HS | 4 | 26 737 | 24 680 | 51 ³ / ₈ 1305 | 34 ⁵ / ₈ 880 | 78 ¹ / ₄ 1988 | 1/3 | 1/2 | 115/208-230/60/1 | 12.2 | 14-20P | 9 2.74 | N/A N/A |

† Depth does not include 2³/₈" (61 mm) for upper rear freezer condensate enclosure.

* Height does not include 5" (127 mm) for castors or 6" (153 mm) for optional legs, and 1" (26 mm) for system mechanical components.



APPROVALS:

AVAILABLE AT:

Model:
TR2DT-4HS

TR Series:
Reach-In Solid Half Door Dual Temperature
Refrigerator / Freezer



STANDARD FEATURES

DESIGN

- True's solid door reach-in's are designed with enduring quality that protects your long term investment.
- Designed using the highest quality materials and components to provide the user with colder product temperatures, lower utility costs and exceptional food safety.

REFRIGERATION SYSTEM

- Two independent, self contained refrigeration systems; CFC free, environmentally friendly and factory balanced.
- R134A refrigerator refrigerant - R404A freezer refrigerant.
- Extra large evaporator coils balanced with higher horsepower compressors and large condensers maintains 33°F to 38°F (.5°C to 3.3°C) in the refrigerator section and -10°F (-23.3°C) in the freezer section.
- Sealed, cast iron, self-lubricating evaporator fan motor(s) and larger fan blades give True reach-in's a more efficient low velocity, high volume airflow design. This unique design ensures faster temperature recovery and shorter run times in the busiest of foodservice environments.
- Top mounted refrigeration system with evaporator position out of food zone to maximize interior capacity.
- Freezer automatic defrost system time-initiated, temperature-terminated. Saves energy consumption and provides shortest possible defrost cycle.
- Automatic evaporator fan motor delay during defrost cycle.

CABINET CONSTRUCTION

- Exterior - 300 series stainless steel doors, front, sides, back and bottom.
- Interior - 300 series stainless steel liner and floor.
- Insulation - entire cabinet structure and solid doors are foamed-in-place using high density, CFC free, polyurethane insulation.
- Welded, heavy duty galvanized frame rail dipped in rust inhibiting enamel paint for corrosion protection inside and out.

- Frame rail fitted with 4" (102 mm) diameter stem castors - locks provided on front set.
- ### DOORS
- 300 series stainless steel exterior and liners. Doors open within cabinet dimensions.
 - Door locks standard.
 - Lifetime guaranteed recessed door handles. Each door fitted with 12" (305 mm) long recessed handle that is foamed-in-place with a sheet metal interlock to ensure permanent attachment.
 - Positive seal self-closing doors with 120° stay open feature. Lifetime guaranteed door hinges.
 - Magnetic door gaskets of one piece construction, removable without tools for ease of cleaning.

SHELVING

- One (1) factory installed interior kit option per full section. Four (4) different interior kits available (see Kit Options). Pilasters and tray slides are factory installed at no charge.

LIGHTING

- Compartmentalized incandescent interior lighting (one per section). Lights activated by rocker switch mounted above top doors, safety shielded.

MODEL FEATURES

- Two (2) exterior digital temperature displays, available with either °F or °C display.
- Evaporator is epoxy coated to eliminate the potential of corrosion.
- Backguard in freezer section improves airflow.
- Minimum wattage heater in cabinet frame and freezer door.

ELECTRICAL

- Unit completely pre-wired at factory and ready for final connection to a 115/208-230/60/1 phase, 3 pole, 4 wire - 20 amp dedicated outlet. Cord and plug set included.



115/208-230/1
NEMA-14-20R

OPTIONAL FEATURES/ACCESSORIES

Upcharge and lead times may apply.

- 6" (153 mm) standard legs.
- 6" (153 mm) seismic/flanged legs.
- 6" (153 mm) stainless steel legs.
- Stainless steel rail skirt for use with legs (field installed).
- Metal door handles (factory installed).
- Novelty baskets.
- Electronic temperature control (factory installed).
- Correctional facilities options.
- Curb mountable units.
- Remote cabinets (condensing units supplied by others; system comes standard with 404A expansion valve and requires R404A refrigerant). Consult factory technical service department for BTU information.

KIT OPTIONS

- Kit #1: Nine (9) sets of #1 type tray slides and pilasters (factory installed), bottom support of one (1) 18" L x 26" D (458 mm x 661 mm) pan or two (2) 14" L x 18" D (356 mm x 458 mm) pans.
- Kit #2: One (1) set half-section #2 steel rod tray slides and pilasters (factory installed), rim support of one (1) 18" L x 26" D (458 mm x 661 mm) pan.
- Kit #3: Six (6) sets of universal type tray slides and pilasters (factory installed), bottom support of one (1) 18" L x 26" D (458 mm x 661 mm) pan, two (2) 14" L x 18" D (356 mm x 458 mm) pans or two (2) 12" L x 20" D (305 mm x 508 mm) pans.
- Kit #4: Three (3) chrome shelves 21¹³/₁₆" L x 28¹³/₁₆" D (555 mm x 732 mm). Four (4) shelf supports included per shelf (factory installed); adjustable on 6" (153 mm) increments. Optional wall mounted shelf support pilasters (factory installed) with four (4) shelf clips per shelf available; adjustable on 1/2" (13 mm) increments.
- Additional kit option components available individually.

PLAN VIEW

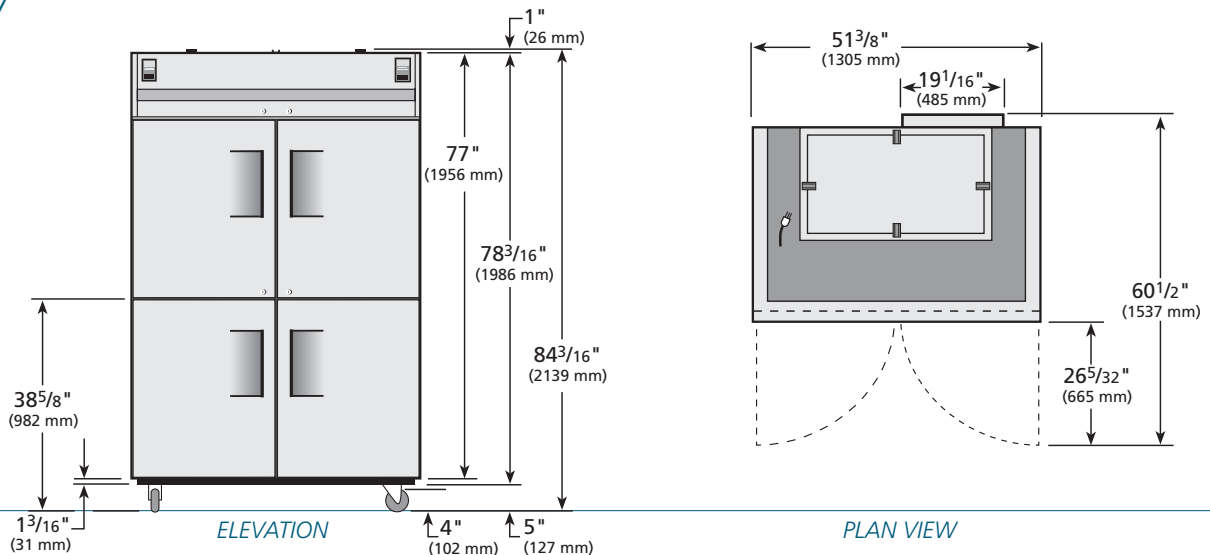

WARRANTY

One year warranty on all parts and labor and an additional 4 year warranty on compressor. (U.S.A. only)

METRIC DIMENSIONS ROUNDED UP TO THE NEAREST WHOLE MILLIMETER
SPECIFICATIONS SUBJECT TO CHANGE WITHOUT NOTICE



| Model | Elevation | Right | Plan | 3D |
|-----------|-----------|---------|---------|---------|
| TR2DT-4HS | TFQA01E | TFQA01S | TFQA01P | TFQA013 |

TRUE FOOD SERVICE EQUIPMENT

2001 East Terra Lane • P.O. Box 970 • O'Fallon, Missouri 63366 • (636)240-2400 • Fax (636)272-2408 • (800)325-6152 • Intl. Fax# (001)636-272-7546 • www.truemfg.com