



TRUE FOOD SERVICE EQUIPMENT, INC.

St. Charles Industrial Center • P.O. Box 970 • O'Fallon, Missouri 63366
(636)240-2400 • FAX (636)272-2408 • (800)325-6152 • www.truemfg.com
Parts Dept. (800)424-TRUE • Parts Dept. FAX# (636)272-9471

Project Name: _____

Location: _____

Item #: _____ Qty: _____

Model #: _____

A/A #

SIS #

Model:
TR1H-1S

TR Specification Series: *Reach-In Solid Door Heated Cabinet*



TR1H-1S

- ▶ Provides cabinet holding temperature of 80°F to 180°F (26.6°C to 82.2°C).
- ▶ Cabinet equipped with low-velocity fans to assure even temperature distribution throughout the cabinet. Fans are controlled by exterior on/off switch.
- ▶ Two (2) stainless steel (for corrosion resistance), finned tube heating elements (1000 watts each) for uniform generation of electric heat. Cabinet comes with a total of 2000 watts.
- ▶ 300 series stainless steel exterior and interior. The very finest stainless with higher tensile strength for fewer dents and scratches.
- ▶ Cabinet comes equipped with one (1) interior kit option per full section standard, factory installed. Four (4) different interior kits available.
- ▶ Entire cabinet structure and solid door are foamed-in-place using high density, CFC free, polyurethane insulation.
- ▶ Positive seal self-closing doors with 120° stay open feature. Lifetime guaranteed door hinges and recessed door handle.

ROUGH-IN DATA

Specifications subject to change without notice.
Chart dimensions rounded up to the nearest 1/8" (millimeters rounded up to next whole number).

Model	Doors	Capacity (Cu. Ft.) (liters)	Cabinet Dimensions (inches) (mm)			Watts	Voltage	Amps	NEMA Config.	Cord Length (total ft.) (total m)	Crated Weight (lbs.) (kg)
			L	D†	H*						
TR1H-1S	1	31 878	29 737	34 ⁵ / ₈ 880	78 ¹ / ₄ 1988	2000	115/208-240/1	8.3	14-20P	9 2.74	350 159

† Depth does not include 1 1/8" (29 mm) for system mechanical components.

* Height does not include 6 1/8" (156 mm) for legs, 5" (127 mm) for optional castors and 1" (26 mm) for system mechanical components.

Requires 115/208 -240/60 Hz, single phase, 3 pole, 4 wire circuit.



12/05

Printed in U.S.A.

APPROVALS:

AVAILABLE AT:

Model:
TR1H-1S

TR Specification Series:
Reach-In Solid Door Heated Cabinet



STANDARD FEATURES

DESIGN

- True's solid door reach-in heated cabinets are designed with enduring quality that protects your long term investment.

HEATER SYSTEM

- Cabinet is designed to provide holding temperatures of 80°F to 180°F (26.6°C to 82.2°C). Heating system controlled by exterior on/off switch and temperature control dial.
- Two (2) stainless steel (for corrosion resistance), finned tube heating elements (1000 watts each) for uniform generation of electric heat. Cabinet comes with a total of 2000 watts.
- Cabinet equipped with low-velocity fans to assure even temperature distribution throughout the cabinet. Fans are controlled by exterior on/off switch.
- Manually controlled vent located on top of the cabinet for positive humidity control.
- Exterior dial thermometer; accurate direct reading of internal cabinet temperature.

CABINET CONSTRUCTION

- Exterior - 300 series stainless steel door, front, sides, back and bottom.
- Interior - 300 series stainless steel liner and floor.
- Insulation - entire cabinet structure and solid door are foamed-in-place using high density, CFC free, polyurethane insulation.
- Welded, heavy duty galvanized frame rail dipped in rust inhibiting enamel paint for corrosion protection inside and out.
- Frame rail fitted with 6" (153 mm) stainless steel legs.

DOOR

- 300 series stainless steel exterior and door liner. Door opens within cabinet dimension. Door lock standard.

- Lifetime guaranteed recessed door handle. Door fitted with 12" (305 mm) long recessed handle that is foamed-in-place with a sheet metal interlock to insure permanent attachment.
- Positive seal self-closing door with 120° stay open feature. Lifetime guaranteed door hinges and torsion type closure system.
- Magnetic door gasket of one piece construction, removable without tools for ease of cleaning.

SHELVING

- One (1) factory installed, interior kit option per full section. Four (4) different interior kits available (see Kit Options). Pilasters and tray slides are factory installed at no charge.

LIGHTING

- Incandescent interior lighting; safety shielded. Lights activated by exterior on/off switch.

MODEL FEATURES

- True heated cabinets are designed to hold warm baked or cooked food. Cabinets are not designed to heat ambient or cold product.
- NSF-4 compliant for open food product.

ELECTRICAL

- True requires that a sole use circuit be dedicated for the unit.
- Unit completely pre-wired at factory and ready for final connection to a 115/208-240/60 Hz. single phase - 20 amp dedicated outlet. Cord and plug set included.



115/208-240/
NEMA-14-20R

OPTIONAL FEATURES/ACCESSORIES

- Seismic/flanged legs.
- 4" (102 mm) diameter swivel castors.
- Stainless steel rail skirt for use with legs (field installed).
- Stainless steel (electro polished) shelves.
- Metal door handle (factory installed).
- Electronic temperature control (factory installed).
- Correctional facilities options.
- Curb mountable units.
- Export units - consult factory.
- Prison package options - consult factory.

KIT OPTIONS

- Kit #1: Nine (9) sets of #1 type tray slides and pilasters (factory installed), bottom support of one (1) 18" L x 26" D (458 mm x 661 mm) pan or two (2) 14" L x 18" D (356 mm x 458 mm) pans.
- Kit #2: One (1) set half-section #2 steel rod tray slides and pilasters (factory installed), rim support of one (1) 18" L x 26" D (458 mm x 661 mm) pan.
- Kit #3: Six (6) sets of universal type tray slides and pilasters (factory installed), bottom support of one (1) 18" L x 26" D (458 mm x 661 mm) pan, two (2) 12" L x 20" D (305 mm x 508 mm) pans or two (2) 14" L x 18" D (356 mm x 458 mm) pans.
- Kit #4: Three (3) chrome shelves 25" L x 27³/₄" D (635 mm x 705 mm) with shelf clips and wall mounted pilasters (factory installed). 1¹/₁₆" (27 mm) standoff insures optimum airflow. Shelves adjustable on 6" (153 mm) increments.
- Additional kit option components available individually.

PLAN VIEW

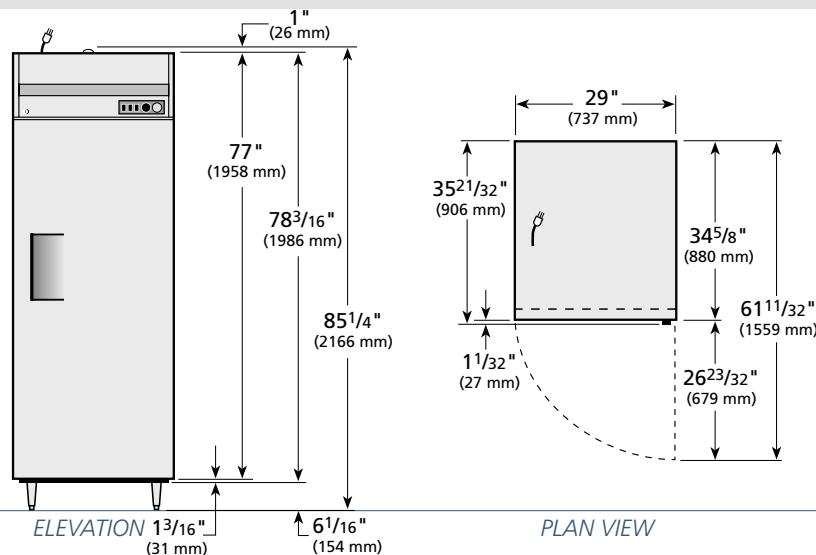

WARRANTY
One year warranty on all parts and labor (U.S.A. only)

METRIC DIMENSIONS ROUNDED UP TO THE NEAREST WHOLE MILLIMETER
SPECIFICATIONS SUBJECT TO CHANGE WITHOUT NOTICE



Model	Elevation	Right	Plan	3D
TR1H-1S	TFQY179E	TFQY179S	TFQX60P	TFQY1793

TRUE FOOD SERVICE EQUIPMENT