



TRUE FOOD SERVICE EQUIPMENT, INC.

2001 East Terra Lane • P.O. Box 970 • O'Fallon, Missouri 63366
(636)240-2400 • FAX (636)272-2408 • (800)325-6152 • www.truemfg.com
Parts Dept. (800)424-TRUE • Parts Dept. FAX# (636)272-9471

Project Name: _____

A/A #

Location: _____

Item #: _____ Qty: _____

SIS #

Model #: _____

Model:
TR1F-1S

TR Series:
Reach-In Solid Door Freezer



TR1F-1S

- ▶ Designed using the highest quality materials and components to provide the user with colder product temperatures, lower utility costs and exceptional food safety.
- ▶ Oversized, factory balanced, refrigeration system holds -10°F (-23.3°C) for the best in food preservation. Ideal for frozen foods and ice cream.
- ▶ 300 series stainless steel exterior and interior. The very finest stainless with higher tensile strength for fewer dents and scratches.
- ▶ Equipped with one (1) interior kit option per full section, factory installed. Four (4) different interior kits available.
- ▶ Positive seal self-closing door with 120° stay open feature. Lifetime guaranteed door hinges.
- ▶ Lifetime guaranteed recessed door handle.
- ▶ Entire cabinet structure and solid door are foamed-in-place using high density, CFC free, polyurethane insulation.
- ▶ Automatic defrost system time-initiated, temperature-terminated. Saves energy consumption and provides shortest possible defrost cycle.

ROUGH-IN DATA

Specifications subject to change without notice.
Chart dimensions rounded up to the nearest 1/8" (millimeters rounded up to next whole number).

Model	Doors	Capacity (Cu. Ft.) (liters)	Cabinet Dimensions (inches) (mm)			HP	Voltage	Amps	NEMA Config.	Cord Length (total ft.) (total m)	Crated Weight (lbs.) (kg)
			L	D	H*						
TR1F-1S	1	31 878	29 737	34 ⁵ / ₈ 880	78 ¹ / ₄ 1988	1/2	115/60/1	10.8	5-15P	9 2.74	410 186

* Height does not include 5" (127 mm) for castors, 6" (153 mm) for optional legs, and 1" (26 mm) for system mechanical components.



7/06

Printed in U.S.A.

APPROVALS:

AVAILABLE AT:

Model:
TR1F-1S

TR Series:
Reach-In Solid Door
Freezer



STANDARD FEATURES

DESIGN

- True's solid door reach-in's are designed with enduring quality that protects your long term investment.
- Designed using the highest quality materials and components to provide the user with colder product temperatures, lower utility costs and exceptional food safety.

REFRIGERATION SYSTEM

- Factory engineered, self-contained, capillary tube system using environmentally friendly (CFC free) 404A refrigerant.
- Extra large evaporator coil balanced with higher horsepower compressor and large condenser maintains -10°F (-23.3°C) cabinet temperature. Ideal for both frozen foods and ice cream.
- Sealed, cast iron, self-lubricating evaporator fan motor(s) and larger fan blades give True reach-in's a more efficient low velocity, high volume airflow design. This unique design insures faster temperature recovery and shorter run times in the busiest of foodservice environments.
- Top mounted refrigeration system with evaporator positioned out of food zone to maximize capacity.
- Automatic defrost system time-initiated, temperature-terminated. Saves energy consumption and provides shortest possible defrost cycle.
- Automatic evaporator fan motor delay during defrost cycle.

CABINET CONSTRUCTION

- Exterior - 300 series stainless steel door, front, sides, back and bottom.
- Interior - 300 series stainless steel liner and floor.
- Insulation - entire cabinet structure and solid door are foamed-in-place using high density, CFC free, polyurethane insulation.
- Welded, heavy duty galvanized frame rail dipped in rust inhibiting enamel paint for corrosion protection inside and out.
- Frame rail fitted with 4" (102 mm) diameter stem castors - locks provided on front set.

DOOR

- 300 series stainless steel exterior and liner. Door open within cabinet demension.
- Door lock standard.
- Positive seal self-closing door with 120° stay open feature. Lifetime guaranteed door hinges.
- Lifetime guaranteed recessed door handle. Door fitted with 12" (305 mm) long recessed handle that is foamed-in-place with a sheet metal interlock to ensure permanent attachment.
- Positive seal self-closing door with 90° stay open feature. Lifetime guaranteed door hinges.
- Magnetic door gasket of one piece construction, removable without tools for ease of cleaning.

SHELVING

- One (1) factory installed interior kit option per full section. Four (4) different interior kits available (see Kit Options). Pilasters and tray slides are factory installed at no charge.

LIGHTING

- Incandescent interior lighting - lights activated by rocker switch mounted above door, safety shielded.

MODEL FEATURES

- Exterior digital temperature display, available with either °F or °C display.
- Evaporator epoxy coated to eliminate the potential of corrosion.
- Backguard improves airflow.
- Minimum wattage heater in cabinet frame and door.
- NSF-7 compliant for open food product.

ELECTRICAL

- Unit completely pre-wired at factory and ready for final connection to a 115/60/1 phase - 15 amp dedicated outlet. Cord and plug set included.



115/60/1
NEMA-5-15R

OPTIONAL FEATURES/ACCESSORIES

Upcharge and lead times may apply.

- 6" (153 mm) standard legs.
- 6" (153 mm) seismic/flanged legs.
- 6" (153 mm) stainless steel legs.
- Stainless steel rail skirt for use with legs (field installed).
- Metal door handle (factory installed).
- Electronic temperature control (factory installed).
- Correctional facilities options.
- Curb mountable units.
- Remote cabinets (condensing unit supplied by others; system comes standard with 404A expansion valve and requires R404A refrigerant). Consult factory technical service department for BTU information.

KIT OPTIONS

- Kit #1: Nine (9) sets of #1 type tray slides and pilasters (factory installed), bottom support of one (1) 18" L x 26" D (458 mm x 661 mm) pan or two (2) 14" L x 18" D (356 mm x 458 mm) pans.
- Kit #2: One (1) set half-section #2 steel rod tray slides and pilasters (factory installed), rim support of one (1) 18" L x 26" D (458 mm x 661 mm) pan.
- Kit #3: Six (6) sets of universal type tray slides and pilasters (factory installed), bottom support of one (1) 18" L x 26" D (458 mm x 661 mm) pan, two (2) 14" L x 18" D (356 mm x 458 mm) pans or two (2) 12" L x 20" D (305 mm x 508 mm) pans.
- Kit #4: Three (3) chrome shelves 25" L x 27³/₄" D (635 mm x 705 mm). Four (4) shelf supports included per shelf (factory installed). Shelves adjustable on 6" (153 mm) increments.
- Additional kit option components available individually.

PLAN VIEW

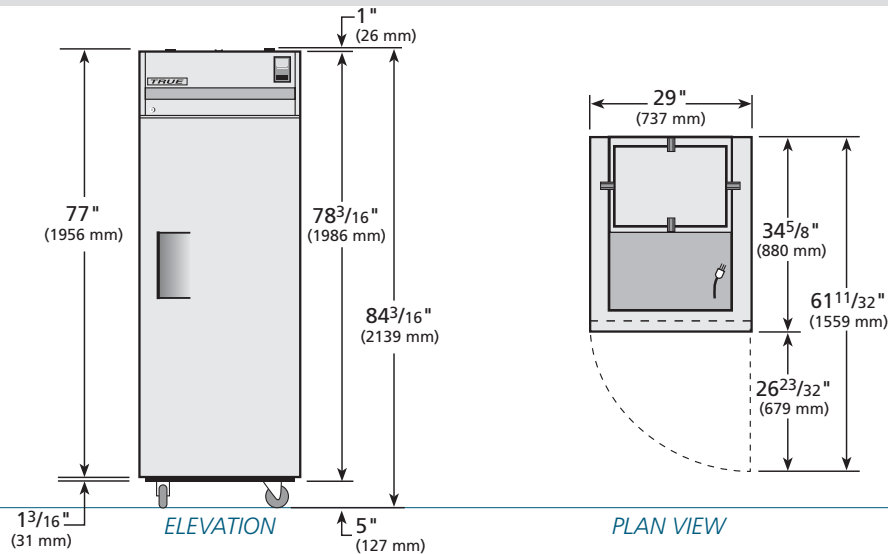

WARRANTY

One year warranty on all parts and labor and an additional 4 year warranty on compressor. (U.S.A. only)

METRIC DIMENSIONS ROUNDED UP TO THE NEAREST WHOLE MILLIMETER
SPECIFICATIONS SUBJECT TO CHANGE WITHOUT NOTICE



Model	Elevation	Right	Plan	3D
TR1F-1S	TFQY50E	TFQX72S	TFQX60P	TFQX723

TRUE FOOD SERVICE EQUIPMENT

2001 East Terra Lane • P.O. Box 970 • O'Fallon, Missouri 63366 • (636)240-2400 • FAX (636)272-2408 • (800)325-6152 • www.truemfg.com