



**TRUE FOOD SERVICE EQUIPMENT, INC.**

2001 East Terra Lane • P.O. Box 970 • O'Fallon, Missouri 63366  
 (636)240-2400 • Fax (636)272-2408 • (800)325-6152 • Intl Fax# (001)636-272-7546  
 Parts Dept. (800)424-TRUE • Parts Dept. Fax# (636)272-9471 • www.truemfg.com

Project Name: \_\_\_\_\_

A/A #

Location: \_\_\_\_\_

Item #: \_\_\_\_\_ Qty: \_\_\_\_\_

SIS #

Model #: \_\_\_\_\_

Model:  
**TPP-44**

**Pizza Prep Table:**  
*Soild Door Refrigerator*



**TPP-44**

- ▶ True's pizza prep tables are designed with enduring quality that protects your long term investment.
- ▶ Oversized, environmentally friendly (R134A) forced-air refrigeration system holds 33°F to 41°F (.5°C to 5°C).
- ▶ Complies with and listed under ANSI/NSF-7-1997-6.3.
- ▶ All stainless steel front, top and cabinet ends. Matching aluminum finished back.
- ▶ Stainless steel, patented, foam insulated flat lid keeps pans' temperature colder, locks in freshness, and minimizes condensation.
- ▶ Extra-deep 19½" (496 mm) full length removable cutting board included. Sanitary, high-density, NSF approved white polyethylene provides tough preparation surface.
- ▶ Foamed-in-place, high density polyurethane insulation (CFC free).
- ▶ Heavy duty PVC coated wire shelves.

**ROUGH-IN DATA**

Specifications subject to change without notice.  
 Chart dimensions rounded up to the nearest 1/8" (millimeters rounded up to next whole number).

Model	Doors	Capacity (Cu. Ft.) (liters)	Shelves	Pans (top)	Cabinet Dimensions (inches) (mm)			HP	Voltage	Amps	NEMA Config.	Cord Length (total ft.) (total m)	Crated Weight (lbs.) (kg)
					L**	D†	H*						
TPP-44	1	11.4 323	2	6	44½	32¼	35¾	1/3	115/60/1	8.6	5-15P	9 2.74	305 139
					1131	820	909	1/3	230-240/50/1	3.8			

\*\* Length does not include 1/4" (7 mm) each side for cutting board brackets and thumb screws.

▲ Plug type varies by country.

† Depth does not include 1" (26 mm) for rear bumpers and 3" (77 mm) for cutting board.

\* Height does not include 6¼" (159 mm) for castors or 6" (153 mm) for optional legs.



6/07

Printed in U.S.A.

APPROVALS:

AVAILABLE AT:

Model:  
**TPP-44**

**Pizza Prep Table:**  
Solid Door Refrigerator



**STANDARD FEATURES**

**DESIGN**

- True's commitment to using the highest quality materials and oversized refrigeration systems provides the user with colder product temperatures, lower utility costs, exceptional food safety and the best value in today's food service marketplace.

**REFRIGERATION SYSTEM**

- Factory engineered, self-contained capillary tube system using environmentally friendly (CFC free) R134A refrigerant.
- Oversized, factory balanced refrigeration system with guided airflow to provide uniform temperature in food pan rail and cabinet interior.
- Forced-air design holds 33°F to 41°F (5°C to 5°C) product temperature in food pans and cabinet interior. Complies with and listed under ANSI/NSF-7-1997-6.3.
- Condensing unit accessed from front behind removable panel on right hand side of cabinet, slides out for easy maintenance.

**CABINET CONSTRUCTION**

- Exterior - stainless steel front, top and cabinet ends. Matching aluminum finished back.
- Interior - attractive, NSF approved, white aluminum liner. 300 series stainless floor with coved corners.
- Insulation - entire cabinet structure and solid door are foamed-in-place using high density, CFC free, polyurethane insulation.
- 5" (127 mm) diameter stem castors. 36" (915 mm) work surface height.

**DOOR**

- Stainless steel exterior with white aluminum liner to match cabinet interior.
- Door fitted with 12" (305 mm) long recessed handle that is foamed-in-place with a sheet metal interlock to ensure permanent attachment.
- Positive seal door swings within cabinet dimensions.
- Magnetic door gasket of one piece construction, removable without tools for ease of cleaning.

**SHELVING**

- Two (2) adjustable, heavy duty PVC coated wire shelves 25" L x 27<sup>3</sup>/<sub>4</sub>" D (635 mm x 705 mm). Four (4) chrome plated shelf clips included per shelf.
- Shelf support pilasters made of same material as cabinet interior; shelves are adjustable on 1/2" (13 mm) increments.

**MODEL FEATURES**

- Evaporator is epoxy coated to eliminate the potential of corrosion.
- Extra-deep 19<sup>1</sup>/<sub>2</sub>" (496 mm) full length removable cutting board included. Sanitary, high-density, NSF approved white polyethylene provides tough preparation surface.
- Stainless steel, patented, foam insulated flat lid keeps pan temperatures colder, locks in freshness, and minimizes condensation.
- Refrigerated pan rail comes standard with six (1/3 size) 12<sup>3</sup>/<sub>4</sub>" L x 6<sup>1</sup>/<sub>4</sub>" W x 6" D (324 mm x 159 mm x 153 mm) NSF approved clear polycarbonate insert pans.
- NSF-7 compliant for open food product.

**ELECTRICAL**

- Unit completely pre-wired at factory and ready for final connection to a 115/60/1 phase - 15 amp dedicated outlet. Cord and plug set included.



115/60/1  
NEMA-5-15R

**OPTIONAL FEATURES/ACCESSORIES**

Upcharge and lead times may apply.

- 230 - 240V / 50 Hz.
- 6" (153 mm) standard legs.
- 6" (153 mm) seismic/flanged legs.
- 3" (85 mm) diameter castors.
- Garnish rack.
- Pizza prep service shelf.
- Single utility shelf.
- Double utility shelf.
- 19<sup>1</sup>/<sub>2</sub>" (496 mm) deep, 1/2" (13 mm) thick, white polyethylene cutting board.
- 19<sup>1</sup>/<sub>2</sub>" (496 mm) deep, 1/2" (13 mm) thick, composite cutting board.
- Half bun tray rack. Holds up to eleven 18" L x 26" D (458 mm x 661 mm) sheet pans (sold separately).
- Exterior round digital temperature display (factory installed).
- Remote cabinets (condensing units supplied by others; system comes standard with 404A expansion valve and requires R404A refrigerant). Consult factory technical service department for BTU information.

**PLAN VIEW**

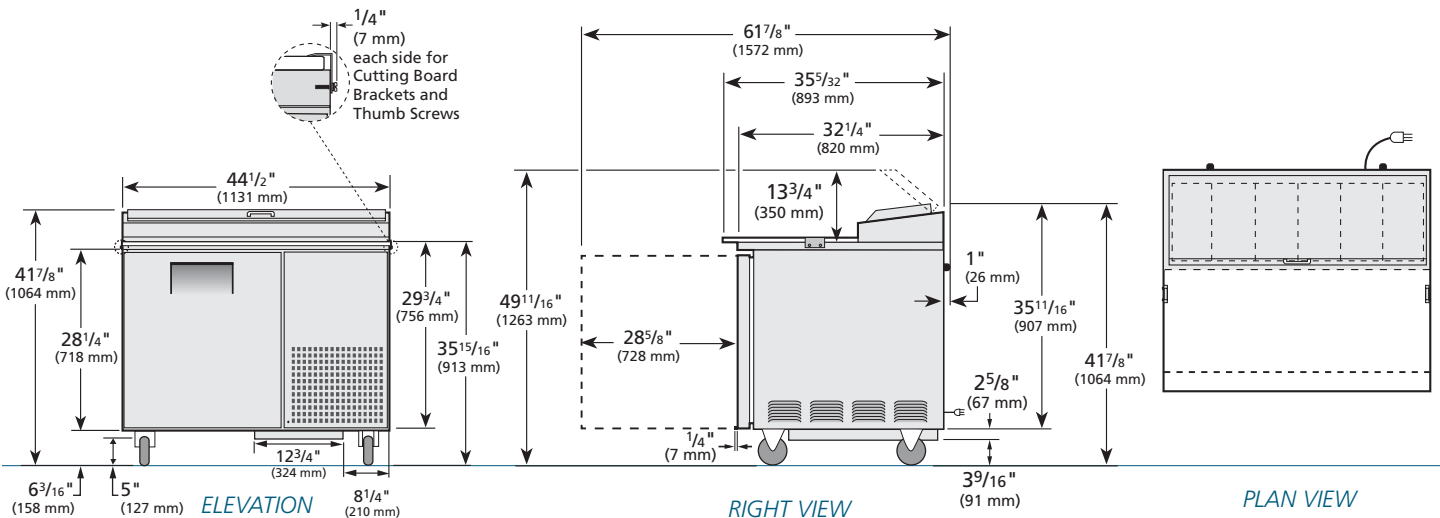

**WARRANTY**  
 One year warranty on all parts and labor and an additional 4 year warranty on compressor. (U.S.A. only)

METRIC DIMENSIONS ROUNDED UP TO THE NEAREST WHOLE MILLIMETER  
 SPECIFICATIONS SUBJECT TO CHANGE WITHOUT NOTICE

	Model	Elevation	Right	Plan	3D
	TPP-44	TFQY10E	TFQY10S	TFQY10P	TFQY1733

**TRUE FOOD SERVICE EQUIPMENT**