



# TRUE FOOD SERVICE EQUIPMENT, INC.

St. Charles Industrial Center • P.O. Box 970 • O'Fallon, Missouri 63366  
(636)240-2400 • FAX (636)272-2408 • (800)325-6152 • www.truemfg.com  
Parts Dept. (800)424-TRUE • Parts Dept. FAX# (636)272-9471

Project Name: \_\_\_\_\_

Location: \_\_\_\_\_

Item #: \_\_\_\_\_ Qty: \_\_\_\_\_

Model #: \_\_\_\_\_

AIA #

SIS #

Model:  
**TMC-49-DS**

## Milk Cooler:

*Dual Sided, White Aluminum Interior / White Vinyl & Stainless Steel Exterior*



## TMC-49-DS

- ▶ True's commitment to using the highest quality materials and oversized refrigeration systems provides the user with colder product temperatures, and lower utility costs in an attractive, durable school milk cooler.
- ▶ Oversized, forced-air refrigeration system maintains milk temperatures of 33°F to 38°F (5°C to 3.3°C). Colder holding temperatures provide better tasting milk, increased sales and less product waste.
- ▶ Exterior - non-peel or chip white laminated vinyl front, sides and back; durable and permanent. Stainless steel top.
- ▶ All stainless steel self-service doors feature convenient drop front and "hold-open" flip-up top. Standard with door locks.
- ▶ Interior - attractive, NSF approved, white aluminum liner with reinforced, 300 series stainless steel floor.
- ▶ Standard with heavy duty floor racks and convenient clean out drain.
- ▶ Designed to hold 12 milk crates.
- ▶ Entire cabinet structure and solid doors are foamed-in-place using high density, CFC free, polyurethane insulation.
- ▶ Dual sided for convenient access to product from both sides of unit.

## ROUGH-IN DATA

Chart dimensions rounded up to the nearest 1/8" (millimeters rounded up to next whole number). Specifications subject to change without notice.

Model	Doors	Capacity (Cu. Ft.) (liters)	Crate Capacity	Floor Racks	Cabinet Dimensions (inches) (mm)			HP	Voltage	Amps	NEMA Config.	Cord Length (total ft.) (total m)	Crated Weight (lbs.) (kg)
					L**	D†	H*						
TMC-49-DS	4	20.9 592	12	3	49 1245	33 <sup>3</sup> / <sub>8</sub> 848	41 <sup>1</sup> / <sub>8</sub> 1045	1/2	115/60/1	9.3	5-15P	9 2.74	445 202

\*\* Length does not include 1/8" (4 mm) each side for lid pins.

† Depth does not include 1" (26 mm) for front bumpers.

\*Height does not include 5 1/8" (131 mm) for castors.



1/06

Printed in U.S.A.

APPROVALS:

AVAILABLE AT:

Model:  
**TMC-49-DS**

**Milk Cooler:**  
*Dual Sided, White Aluminum Interior /  
White Vinyl & Stainless Steel Exterior*



## STANDARD FEATURES

### DESIGN

- True's commitment to using the highest quality materials and oversized refrigeration systems provides the user with colder product temperatures, and lower utility costs in an attractive, durable school milk cooler.

### REFRIGERATION SYSTEM

- Factory engineered, self-contained, capillary tube system using environmentally friendly (CFC free) 134A refrigerant.
- Extra large evaporator coil balanced with higher horsepower compressor and large condenser; maintains milk temperatures of 33°F to 38°F (.5°C to 3.3°C). Colder holding temperatures provide better tasting milk, increased sales and less product waste.
- Sealed, cast iron, self-lubricating evaporator fan motors and larger fan blades give True merchandisers a more efficient, low velocity, high volume airflow design. This unique design insures colder holding temperatures and faster recovery in high use situations.
- Condensing unit accessed from behind back grill, slides out for easy cleaning and maintenance.

### CABINET CONSTRUCTION

- Exterior - non-peel or chip white vinyl front, sides and back; durable and permanent. Stainless steel top.
- Interior - attractive, NSF approved, white aluminum liner with reinforced, 300 series stainless steel floor. Standard with heavy duty floor racks.
- Insulation - entire cabinet structure is foamed-in-place using high density, CFC free, polyurethane insulation.
- Welded, heavy duty galvanized frame rail dipped in rust inhibiting enamel paint for corrosion protection inside and out.
- Frame rail fitted with (4) easy roll, all swivel 4" (102 mm) diameter castors (front castors lock in place).
- Designed to hold 12 milk crates.

### DOORS

- All stainless steel self-service doors feature convenient drop front and "hold-open" flip-up top. Door support bumpers standard.
- Door locks standard.
- Magnetic door gaskets of one piece construction, removable without tools for ease of cleaning.

### MODEL FEATURES

- Evaporator is epoxy coated to eliminate the potential of corrosion.
- Convenient clean out drain with 1/2" (13 mm) NPT-PVC drain plug.
- Listed under NSF-7 for the storage and/or display of packaged or bottled product.

### ELECTRICAL

- Unit completely pre-wired at factory and ready for final connection to a 115/60/1 phase - 15 amp dedicated outlet. Cord and plug set included.



115/60/1  
NEMA-5-15R

### OPTIONAL FEATURES/ACCESSORIES

Upcharge and lead times may apply.

- A variety of exterior color options available, see [www.truemfg.com](http://www.truemfg.com) for latest offerings.
- 6" (153 mm) standard legs (mounting plates required).
- 6" (153 mm) seismic/flanged legs (mounting plates required).
- Corner bumpers.
- See [www.truemfg.com](http://www.truemfg.com) for school milk calculator.
- Remote cabinets (condensing unit supplied by others; system comes standard with 404A expansion valve and requires R404A refrigerant). Consult factory technical service department for BTU information.

## PLAN VIEW

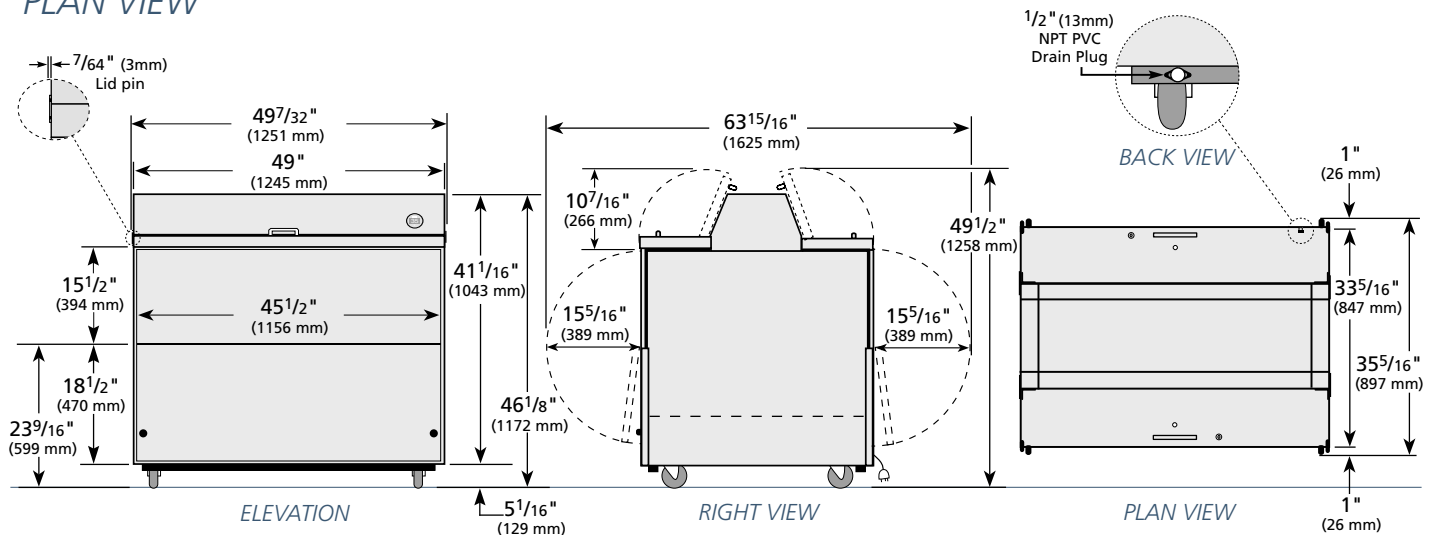

### WARRANTY

One year warranty on all parts & labor and an additional 4 year warranty on compressor. (U.S.A. only)

METRIC DIMENSIONS ROUNDED UP TO THE NEAREST WHOLE MILLIMETER

SPECIFICATIONS SUBJECT TO CHANGE WITHOUT NOTICE



Model	Elevation	Right	Plan	3D
TMC-49-DS	TFQ063E	TFQ062S	TFQ063P	TFQ0633

## TRUE FOOD SERVICE EQUIPMENT

St. Charles Industrial Center • P.O. Box 970 • O'Fallon, Missouri 63366 • (636)240-2400 • FAX (636)272-2408 • (800)325-6152 • [www.truemfg.com](http://www.truemfg.com)