



# TRUE FOOD SERVICE EQUIPMENT, INC.

St. Charles Industrial Center • P.O. Box 970 • O'Fallon, Missouri 63366  
(636)240-2400 • FAX (636)272-2408 • (800)325-6152 • www.truemfg.com  
Parts Dept. (800)424-TRUE • Parts Dept. FAX# (636)272-9471

Project Name: \_\_\_\_\_

A/A #

Location: \_\_\_\_\_

Item #: \_\_\_\_\_ Qty: \_\_\_\_\_

SIS #

Model #: \_\_\_\_\_

Model:  
**THF-41AL**

**Horizontal Freezer:**  
*Glass Angled Lid*



## THF-41AL

- ▶ True's horizontal freezers are uniquely designed to promote high-profit frozen products in high impulse retail traffic areas. Ideal for bolstering incremental sales increases of frozen merchandise and seasonal specialties.
- ▶ Cold wall, environmentally friendly (134A) refrigeration system. Maintains -10°F (-23.3°C), ideal for both ice cream and frozen food.
- ▶ Exterior - non-peel or chip white laminated vinyl with black trim, durable and permanent.
- ▶ Interior - NSF approved, white aluminum with 300 series stainless steel floor.
- ▶ Tempered, hard coated, "Low-E" glass slide lid. Reduces solar heat gain, enhances energy efficiency and minimizes condensation.
- ▶ Locks standard, provide security, prevents theft.
- ▶ Convenient defrost drain.
- ▶ 1 1/2" (39 mm) dual swivel castors.

### ROUGH-IN DATA

Specifications subject to change without notice.

Chart dimensions rounded up to the nearest 1/8" (millimeters rounded up to next whole number).

Model	Doors	Capacity (Cu. Ft.) (liters)	Cabinet Dimensions (inches) (mm)			HP	Voltage	Amps	NEMA Config.	Cord Length (total ft.) (total m)	Crated Weight (lbs.) (kg)
			L	D	H*						
THF-41AL	2 270	9.5	41 1042	25 <sup>3</sup> / <sub>4</sub> 655	33 <sup>7</sup> / <sub>8</sub> 861	1/3	115/60/1	5.6	5-15P	8 2.4	205 93

\* Height does not include 2 1/8" (54 mm) for castors.



7/05

Printed in U.S.A.

#### APPROVALS:

Model:  
**THF-41AL**

**Horizontal Freezer:**  
*Glass Angled Lid*



**STANDARD FEATURES**

**DESIGN**

- True's horizontal freezers are uniquely designed to promote high-profit frozen products in high impulse retail traffic areas. Ideal for bolstering incremental sales increases for frozen merchandise and seasonal specialties.

**REFRIGERATION SYSTEM**

- Factory engineered self-contained, capillary tube system using environmentally friendly (CFC free) 134A refrigerant.
- Cold wall refrigeration system maintains -10°F (-23.3°C) cabinet temperature, ideal for both ice cream and frozen food.
- Condensing unit is accessed from behind grill on right side; slides out for easy maintenance.
- Manual defrost system; convenient drain located on front of cabinet.

**CABINET CONSTRUCTION**

- Exterior - non-peel or chip white laminated vinyl; durable and permanent; with black trim.
- Interior - attractive, NSF approved, white aluminum liner; non-rust, peel or chip. 300 series stainless steel floor.
- Insulation - entire cabinet structure is foamed-in-place using high density, CFC free, polyurethane insulation.
- 1 1/2" (39 mm) diameter dual swivel castors permit easy placement.

**GLASS SLIDE LIDS**

- Tempered, hard coated, "Low-E" Single pane glass slide lid, assemblies reduce solar heat gain and minimize condensation.
- Designed for convenient access, fast service and attractive display.
- Door locks standard.

**MODEL FEATURES**

- Self-contained, portable system. No plumbing required.
- Low profile design permits easier placement, saves aisle space.
- Interior mounted temperature monitor.
- Listed under NSF-7 for the storage and/or display of packaged or bottled product.

**ELECTRICAL**

- Unit completely pre-wired at factory and ready for final connection to a 115/60/1 phase - 15 amp dedicated outlet. Cord and plug set included.



**OPTIONAL FEATURES/ACCESSORIES**

- Upcharge and lead times may apply.
- Black vinyl exterior. See our website [www.truemfg.com](http://www.truemfg.com) for the latest color offerings.
  - Heavy duty novelty baskets (accommodates three).
  - Dividers for novelty baskets.

**PLAN VIEW**

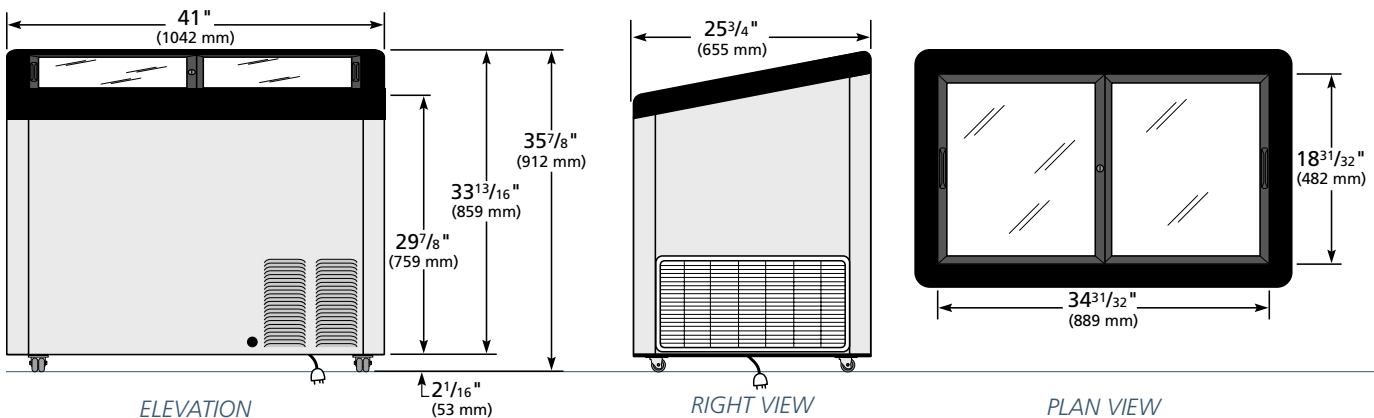

**WARRANTY**  
 One year warranty on all parts & labor and an additional 4 year warranty on compressor. (U.S.A. only)

METRIC DIMENSIONS ROUNDED UP TO THE NEAREST WHOLE MILLIMETER  
 SPECIFICATIONS SUBJECT TO CHANGE WITHOUT NOTICE



Model	Elevation	Right	Plan	3D
THF-41AL	TFEY48E	TFEY48S	TFEY46P	TFEY483

**TRUE FOOD SERVICE EQUIPMENT**