



TRUE FOOD SERVICE EQUIPMENT, INC.

St. Charles Industrial Center • P.O. Box 970 • O'Fallon, Missouri 63366
(636)240-2400 • FAX (636)272-2408 • (800)325-6152 • www.truemfg.com

Project Name: _____

Location: _____

Item #: _____ Qty: _____

Model #: _____

AIA #

SIS #

TH (Heated Cabinet) Series



TH-23

TRUE expands with new strength into the Heated Cabinet market.

Heated Cabinets

TH-23, **TH-23G**

SPECIFICATIONS / FEATURES

CABINET CONSTRUCTION:

- 300 series stainless steel interior and exterior doors and front. Construction of liner in accordance with NSF standards.
- Anodized quality aluminum exterior ends and back.
- Barrel lock standard. Exterior mounted temperature monitor.
- Cabinet mounted on a welded, galvanized frame rail, painted for additional corrosion protection. Frame rail fitted with 4" diameter castors, front castors include brakes).
- Heater is sheathed for maximum corrosion resistance.
- Incandescent interior lighting (fluorescent interior lighting for glass door models).
- Manual humidity control.
- Equipped with 9 foot cord.

DOORS:

- Solid door model feature 300 series stainless steel interior / exterior. Doors extend full width of cabinet shell. Door gaskets of one piece construction.
- Glass door model feature energy efficient "Low-E" thermal glass. Glass assembly within extruded aluminum frame, with reinforcing backing plates in each corner. Glass assembly replaceable without removing the door from hinges. The face of each door fitted with a 15" long handle of same material as door frame.
- Adjustable torsion type closure system with aluminum block supports.

INSULATION:

- Entire cabinet structure and solid doors insulated using foamed-in-place CFC free polyurethane foam.

SHELVING:

- Adjustable, heavy duty chrome plated shelves (3). Shelves capable of supporting up to 250 lbs.
- Full height shelf support pilasters, with double oblong holes on 1/2" centers. Pilasters made of the same material as cabinet interior. Four (4) chrome plated, stainless steel shelf clips to be included for each shelf.

HEATING SYSTEM:

- 850 Watts
- Holds 80°F to 200°F throughout the cabinet for uniform, forced-air convection heating.

ELECTRICAL CHARACTERISTICS:

- Unit completely pre-wired at factory, and ready for final connection to a 115/60/1 phase - 15 amp dedicated outlet. A cord and plug set to be included.
- A sole use circuit is required.



115/60/1
NEMA-5-15R

Printed in U.S.A.



APPROVALS:

Specifications subject to change without notice.

10/03

Exceptions:

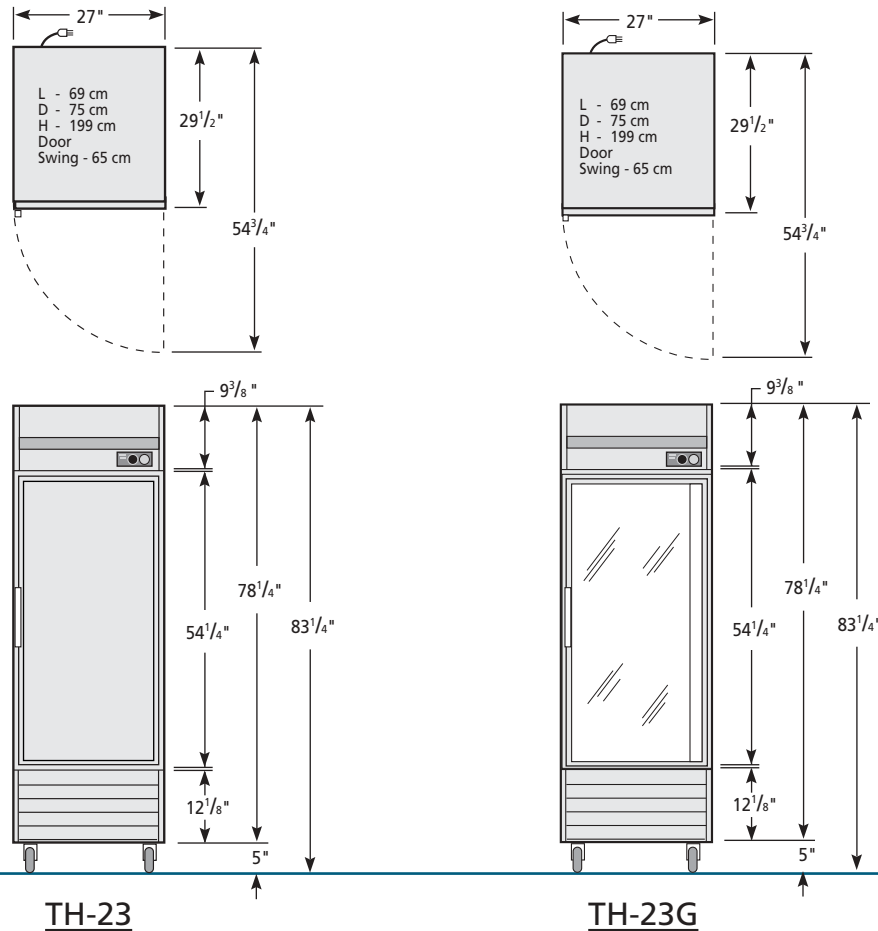

Rough-In Data													
Model	Doors	Capacity (Cu. Ft)	# of Shelves	Dimensions (inches)			Watts	Volts	PH	Amps	NEMA Config.	Cord Length (feet)	Crated Weight
				L	D*	H †							
TH-23	1	23	3	27	29 1/2	78 1/4	850	115	1	7.8	5-15	9	240
TH-23G	1	23	3	27	29 1/2	78 1/4	850	115	1	7.8	5-15	9	276

* Add 1 3/8" for door handle

† Height does not include 5" for castor height or 6" for optional legs.

‡ Height does not include 1 1/4" for ventilator cap.

Specifications subject to change without notice.

Standard Features

- Holds 80°F to 200°F throughout the cabinet for uniform, forced-air heating.
- 300 series stainless steel interior, exterior front and doors.
- .040 anodized quality aluminum ends.
- Heater - sheathed for corrosion resistance.
- Manual humidity control - 12" x 20" water pan standard for contents requiring high humidity.
- Adjustable dial control is a standard feature for low humidity application (turn counterclockwise to ventilate).
- Exterior mounted, color coded, temperature monitor.
- Solid door model features 300 series stainless steel doors. Extruded aluminum door frame on glass door model.
- Energy efficient "Low-E" thermal glass doors. Exterior pane is tempered for safety.
- Magnetic door gaskets.
- Adjustable, heavy duty chrome plated shelves.
- Incandescent interior lighting (fluorescent interior lighting on glass door models).
- Door lock standard.
- 4" diameter swivel castors standard equipment - locking castors provided for front set.
- Equipped with 9 foot cord.
- Foamed-in-place high density polyurethane insulation (CFC free).
- 1 year parts & labor warranty (USA).

Optional Accessories

- 6" stainless steel or optional seismic legs.
- Additional shelves.
- Bun tray racks optional for solid door heated cabinet only.

KCL	Model	Front	Right	Plan	3D
	TH-23	TFEY35E	TFEY06S	TFEY06P	TFEY353
	TH-23G	TFEY36E	TFEY06S	TFEY06P	TFEY363