



TRUE FOOD SERVICE EQUIPMENT, INC.

2001 East Terra Lane • P.O. Box 970 • O'Fallon, Missouri 63366
 (636)240-2400 • Fax (636)272-2408 • (800)325-6152 • Intl Fax# (001)636-272-7546
 Parts Dept. (800)424-TRUE • Parts Dept. Fax# (636)272-9471 • www.truemfg.com

Project Name: _____

A/A #

Location: _____

Item #: _____ Qty: _____

SIS #

Model #: _____

Model:
TDD-2CT-S

Direct Draw Beer Dispenser:
Stainless Steel Solid Door Club Top



TDD-2CT-S

- ▶ True's direct draw beer dispensers are designed with enduring quality and value. Our commitment to using the highest quality materials and oversized refrigeration assures colder product temperatures and years of trouble free service.
- ▶ Easy to reach refrigerated storage area under slide top for chilled product or glasses.
- ▶ Oversized, factory balanced, refrigeration system holds 33°F to 38°F (.5°C to 3.3°C).
- ▶ Exterior - stainless steel doors, front and sides. Matching aluminum back. All stainless steel counter top and lids.
- ▶ Interior - 300 series stainless steel floor with 1/2" (13 mm) reinforced lip and heavy gauge galvanized steel walls. NSF approved for pre-packaged and bottled product.
- ▶ Adjustable, heavy duty PVC coated shelf.
- ▶ 3" (77 mm) diameter stainless steel insulated beer columns. Cold air is directed into beer columns to reduce foaming and maximize draft beer profits.
- ▶ Anodized aluminum glass rail provides convenient storage for glasses on top.
- ▶ Entire cabinet structure and solid doors are foamed-in-place using high density, CFC free, polyurethane insulation.

ROUGH-IN DATA

Specifications subject to change without notice.

Chart dimensions rounded up to the nearest 1/8" (millimeters rounded up to next whole number).

Model	Doors	Capacity 1/2 Barrels	Shelves	Cabinet Dimensions (inches) (mm)			HP	Voltage	Amps	NEMA Config.	Cord Length (total ft.) (total m)	Crated Weight (lbs.) (kg)
				L	D†	H*						
TDD-2CT-S	2	2	1	58 ⁷ / ₈ 1496	27 ¹ / ₈ 689	38 ¹ / ₂ 978	1/3 1/3	115/60/1 230-240/50/1	8.5 4.2	5-15P ▲	7 2.13	330 150

† Depth does not include 1" (26 mm) for rear bumpers.

▲ Plug type varies by country.

* Height does not include 13³/₄" (350 mm) for draft arms.

	APPROVALS: _____ _____	AVAILABLE AT: _____ _____
1/07	Printed in U.S.A.	

Model:
TDD-2CT-S

Direct Draw Beer Dispenser:
Stainless Steel Solid Door Club Top



STANDARD FEATURES

DESIGN

- True's direct draw beer dispensers are designed with enduring quality and value. Our commitment to using the highest quality materials and oversized refrigeration assures colder product temperatures and years of trouble free service.

REFRIGERATION SYSTEM

- Factory engineered, self-contained, capillary tube system using environmentally friendly (CFC free) 134A refrigerant.
- Extra large evaporator coil balanced with higher horsepower compressor and large condenser; maintains cabinet temperatures of 33°F to 38°F (.5°C to 3.3°C).
- Sealed, cast iron, self-lubricating evaporator fan motor(s) and larger fan blades give True beer dispensers a more efficient low velocity, high volume airflow design. This unique design ensures faster temperature pull down of warm product, colder holding temperatures and faster recovery in high use situations.
- Condensing unit accessed from behind front grill, slides out for easy cleaning and maintenance.

CABINET CONSTRUCTION

- Exterior - stainless steel doors, front and sides. Matching aluminum back. All stainless steel counter top and lid.
- Interior - 300 series stainless steel floor with 1/2" (13 mm) reinforced lip and heavy gauge galvanized steel walls.

- Insulation - entire cabinet structure and solid doors are foamed-in-place using high density, CFC free, polyurethane insulation.
- Welded, heavy duty galvanized base rail dipped in rust inhibiting enamel paint for corrosion protection inside and out.
- 3" (77 mm) diameter stainless steel insulated beer columns. Cold air is directed into beer columns to reduce foaming and maximize draft beer profits.
- Anodized aluminum glass rail.

DOORS

- Stainless steel exterior with heavy gauge galvanized steel liner.
- Each door fitted with 12" (305 mm) long recessed handle that is foamed-in-place with a sheet metal interlock to insure permanent attachment.
- Magnetic door gaskets of one piece construction, removable without tools for ease of cleaning.
- Door locks standard.

SHELVING

- One (1) adjustable, heavy duty, black, PVC coated wire shelf 11³/₈" L x 21¹/₄" D (289 mm x 540 mm). Four (4) chrome plated shelf clips included per shelf.
- Aluminum shelf support pilasters; shelves are adjustable on 1/2" (13 mm) increments.

LIGHTING

- Incandescent interior lighting.

MODEL FEATURES

- Evaporator is epoxy coated to eliminate the potential of corrosion.
- Convenient 1/2" (13 mm) barbed T drain fitting located on front of cooler.
- Designed to accommodate all types of beer kegs.
- Listed under NSF-7 for the storage and/or display of packaged or bottled product.

ELECTRICAL

- Unit completely pre-wired at factory and ready for final connection to a 115/60/1 phase - 15 amp dedicated outlet. Cord and plug set included.



115/60/1
NEMA-5-15R

OPTIONAL FEATURES/ACCESSORIES

Upcharge and lead times may apply.

- 230 - 240V / 50 Hz.
- 6" (153 mm) standard legs.
- 6" (153 mm) seismic/flanged legs.
- 2¹/₂" (64 mm) diameter castors.
- 4" (102 mm) diameter castors.
- Double headed draft standard.
- Two-way tapper manifold.
- Three-way tapper manifold.
- Draft cap.
- Remote cabinets (condensing unit supplied by others; system comes standard with 404A expansion valve and requires R404A refrigerant), consult factory technical service department for BTU information.

PLAN VIEW

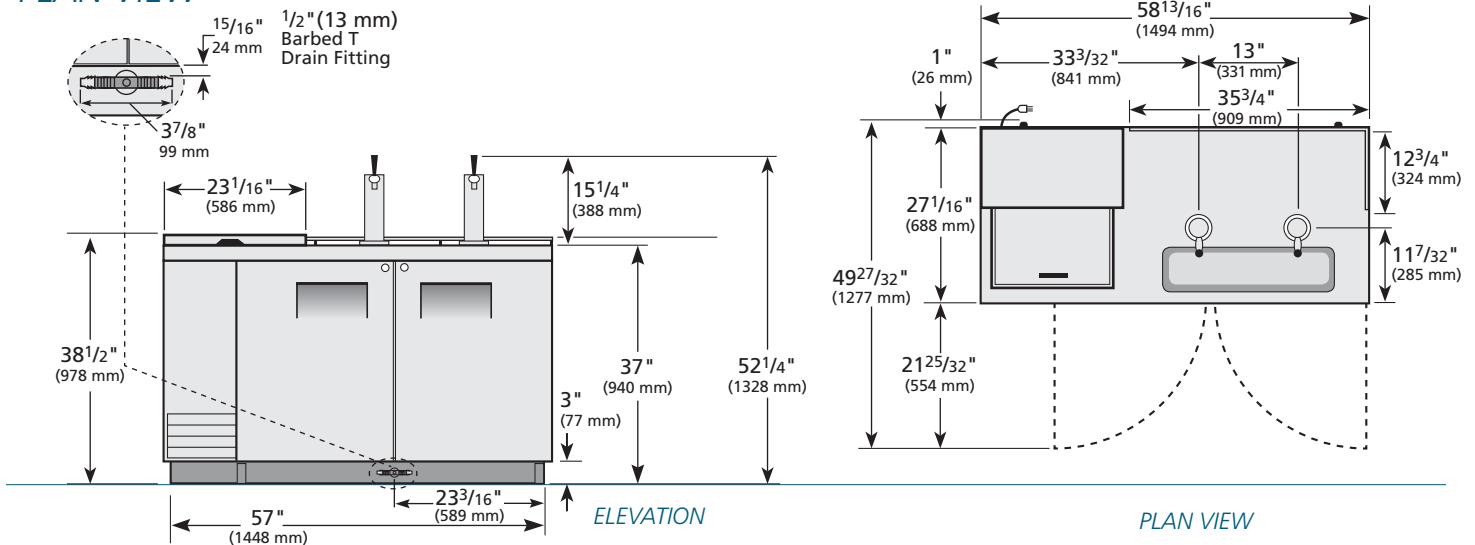

WARRANTY
One year warranty on all parts and labor and an additional 4 year warranty on compressor. (U.S.A. only)

METRIC DIMENSIONS ROUNDED UP TO THE NEAREST WHOLE MILLIMETER
SPECIFICATIONS SUBJECT TO CHANGE WITHOUT NOTICE



Model	Elevation	Right	Plan	3D
TDD-2CT-S	TFSY02E	TFSY02S	TFSY02P	TFSY023

TRUE FOOD SERVICE EQUIPMENT