



TRUE FOOD SERVICE EQUIPMENT, INC.

2001 East Terra Lane • P.O. Box 970 • O'Fallon, Missouri 63366
(636)240-2400 • FAX (636)272-2408 • (800)325-6152 • www.truemfg.com
Parts Dept. (800)424-TRUE • Parts Dept. FAX# (636)272-9471

Project Name: _____

A/A #

Location: _____

Item #: _____ Qty: _____

SIS #

Model #: _____

Model:
TD-50-18-S-LT

Deep Well Horizontal Bottle Cooler: *Low Temperature, Stainless Steel Solid Lid*



TD-50-18-S-LT

- ▶ True's horizontal bottle coolers are designed with enduring quality and value. Our commitment to using the highest quality materials and oversized refrigeration assures colder product temperatures and years of trouble free service.
- ▶ Oversized, factory balanced, refrigeration system holds 20°F (-6.6°C). For applications with high ambient temperatures. Designed for full alcoholic beverages only. Note; some low alcohol products freeze below 32°F (0°C).
- ▶ Forced-air cooling. Positively guided air flow cools bottles on top first. Evaporator coil virtually runs length of cooler for balanced temperatures throughout the cabinet.
- ▶ Exterior - all stainless steel exterior, countertop and lids.
- ▶ Interior - long lasting, heavy duty galvanized steel.
- ▶ Evaporator is epoxy coated to eliminate the potential of corrosion.
- ▶ Entire cabinet structure is foamed-in-place using high density, CFC free, polyurethane insulation.
- ▶ Heavy duty, 10 mil thick pure grade PVC coated adjustable bin dividers.
- ▶ Removable, bottle cap opener and cap catcher.

ROUGH-IN DATA

Specifications subject to change without notice.

Chart dimensions rounded up to the nearest 1/8" (millimeters rounded up to next whole number).

Model	Lids	Capacity		Bin Dividers	Cabinet Dimensions (inches) (mm)			HP	Voltage	Amps	NEMA Config.	Cord Length (total ft.) (total m)	Crated Weight (lbs.) (kg)
		12oz. Btls.	12oz. Cans		L	D [†]	H						
TD-50-18-S-LT	2	16 1/2 cases	24 cases	3	49 5/8 1261	26 5/8 677	33 3/8 848	1/3	115/60/1	8.2	5-15P	7 2.13	255 116

† Depth does not include 1 1/2" (39 mm) for cap catcher and 1" (26 mm) for rear bumpers.

Note: 12 oz. bottles refers to 12 oz. longneck bottles.



9/06

Printed in U.S.A.

APPROVALS:

AVAILABLE AT:

Model:
TD-50-18-S-LT

Deep Well Horizontal Bottle Cooler:

Low Temperature, Stainless Steel Solid Lid



STANDARD FEATURES

DESIGN

- True's horizontal bottle coolers are designed with enduring quality and value. Our commitment to using the highest quality materials and oversized refrigeration assures colder product temperatures and years of trouble free service.

REFRIGERATION SYSTEM

- Factory engineered, self-contained, capillary tube system using environmentally friendly (CFC free) R404A refrigerant.
- Extra large evaporator coil balanced with higher horsepower compressor and large condenser.
- Maintains 20°F (-6.6°C) for applications with high ambient temperatures. Designed for full alcoholic beverages only. Note; some low alcohol products freeze below 32°F (0°C).
- Sealed, cast iron, self-lubricating evaporator fan motor(s) and larger fan blades give True merchandisers a more efficient low velocity, high volume airflow design. This unique design ensures colder standard temperatures and faster recovery in high use situations.
- Condensing unit accessed from behind front grill, slides out for easy maintenance.

- Automatic defrost system time-initiated, time-terminated
- Forced-air cooling. Positively guided air flow cools bottles on top first. Evaporator coil virtually runs length of cooler for balanced temperatures throughout the cabinet.

CABINET CONSTRUCTION

- Exterior - all stainless steel exterior, countertop and lids.
- Interior - long lasting, heavy duty galvanized steel.
- Insulation - entire cabinet structure is foamed-in-place using high density, CFC free, polyurethane insulation.
- Welded heavy gauge galvanized steel base rail dipped in rust inhibiting enamel paint for corrosion protection inside and out.
- Removable, bottle cap opener and cap catcher.

BIN DIVIDERS

- Three (3) heavy duty, 10 mil thick pure grade PVC coated adjustable bin dividers to maximize storage.

MODEL FEATURES

- Evaporator is epoxy coated to eliminate the potential of corrosion.

ELECTRICAL

- Unit completely pre-wired at factory and ready for final connection to a 115/60/1 phase - 15 amp dedicated outlet. Cord and plug set included.



115/60/1
NEMA-5-15R

OPTIONAL FEATURES/ACCESSORIES

Upcharge and lead times may apply.

- 6" (153 mm) standard legs.
- 6" (153 mm) seismic/flanged legs.
- 2 1/2" (64 mm) diameter rail castors.
- 3" (77 mm) diameter rail castors.
- Ratchet locks and handles. Requires one per lid.
- Remote cabinets (condensing unit supplied by others; system comes standard with 404A expansion valve and requires R404A refrigerant). Consult factory technical service department for BTU information.

PLAN VIEW

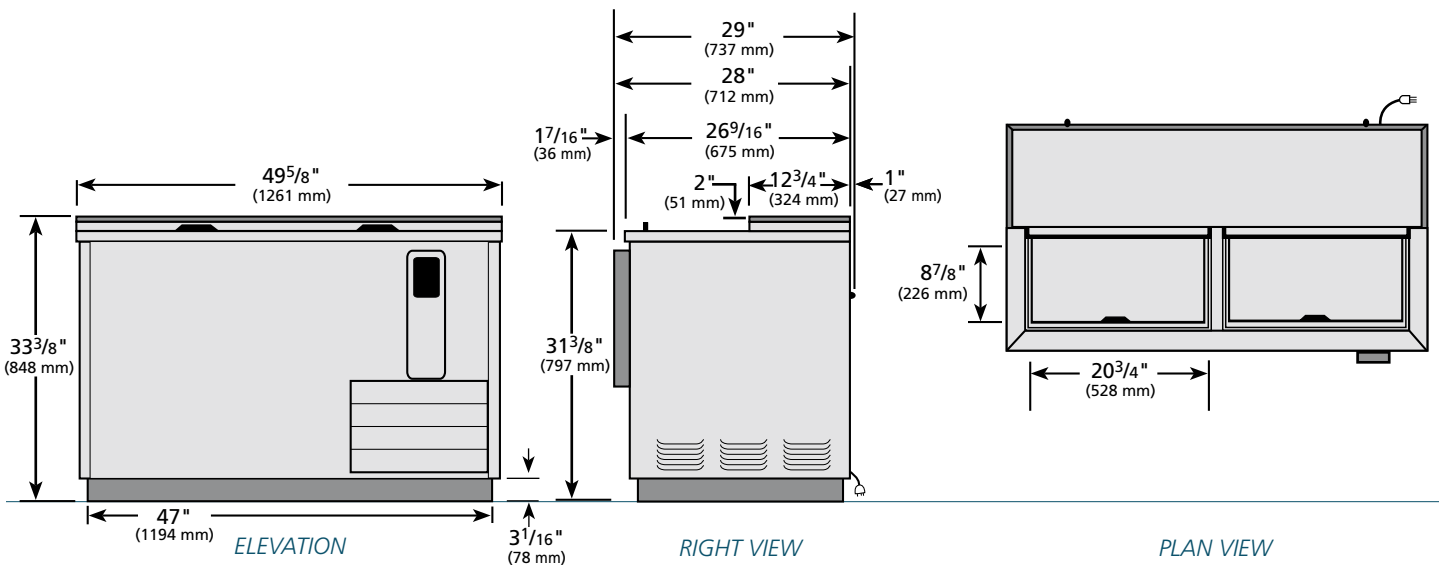

WARRANTY

One year warranty on all parts and labor and an additional 4 year warranty on compressor. (U.S.A. only)

METRIC DIMENSIONS ROUNDED UP TO THE NEAREST WHOLE MILLIMETER

SPECIFICATIONS SUBJECT TO CHANGE WITHOUT NOTICE



Model	Elevation	Right	Plan	3D
TD-50-18-S-LT	TFKY03E	TFKY01S	TFKY03P	TFKY033

TRUE FOOD SERVICE EQUIPMENT

2001 East Terra Lane • P.O. Box 970 • O'Fallon, Missouri 63366 • (636)240-2400 • FAX (636)272-2408 • (800)325-6152 • www.truemfg.com