



**TRUE FOOD SERVICE EQUIPMENT, INC.**

St. Charles Industrial Center • P.O. Box 970 • O'Fallon, Missouri 63366  
 (636)240-2400 • FAX (636)272-2408 • (800)325-6152 • www.truemfg.com  
 Parts Dept. (800)424-TRUE • Parts Dept. FAX# (636)272-9471

Project Name: \_\_\_\_\_

Location: \_\_\_\_\_

Item #: \_\_\_\_\_ Qty: \_\_\_\_\_

Model #: \_\_\_\_\_

A/A #

SIS #

Model:  
**TCGR-50-CD**

**Display Case:**  
*Curved Glass Refrigerated Cold Deli Case*



**TCGR-50-CD**

- ▶ True's refrigerated cold deli case combines efficient, high volume merchandising and exceptional refrigeration with an elegant curved glass front for sophisticated presentation of deli products.
- ▶ Self-contained, environmentally friendly (CFC free) 134A refrigeration system.
- ▶ More efficient low velocity, high volume airflow design maintains 36°F to 38°F (2.2°C to 3.3°C) without drying out product. Ideally suited for deli meats and cheeses.
- ▶ Cabinet is NSF-7 certified to hold open food product.
- ▶ Insulated, double pane curved glass front and side glass panels provide extra large viewing area to maximize deli product presentation. Front glass tilts forward for easy cleaning.
- ▶ One (1) adjustable, cantilevered, lighted, stainless mezzanine shelf.
- ▶ Low UV emitting fluorescent lighting system.
- ▶ Front and sides standard with white laminate panels, five additional color options available at no charge. Stainless steel top and interior walls.

**ROUGH-IN DATA**

Specifications subject to change without notice.  
 Chart dimensions rounded up to the nearest 1/8" (millimeters rounded up to next whole number).

Model	Doors	Capacity (Cu. Ft.) (liters)	Shelves	Cabinet Dimensions (inches) (mm)			HP	Voltage	Amps	NEMA Config.	Cord Length (total ft.) (total m)	Crated Weight (lbs.) (kg)
				L	D	H						
TCGR-50-CD	2	27.4 776	1	50 <sup>7</sup> / <sub>8</sub> 1293	35 <sup>1</sup> / <sub>2</sub> 902	47 <sup>7</sup> / <sub>8</sub> 1217	1/2	115/60/1	15.2	5-20P	9 2.74	580 264



12/05 Printed in U.S.A.

**APPROVALS:**  
 \_\_\_\_\_  
 \_\_\_\_\_

**AVAILABLE AT:**  
 \_\_\_\_\_  
 \_\_\_\_\_

Model:  
**TCGR-50-CD**

**Display Case:**  
*Curved Glass Refrigerated Cold Deli Case*



**STANDARD FEATURES**

**DESIGN**

- True's refrigerated cold deli case combines efficient, high volume merchandising and exceptional refrigeration with an elegant curved glass front for sophisticated presentation of deli products.
- Designed to provide an attractive companion to our "refrigerated" and "dry" display cases.

**REFRIGERATION SYSTEM**

- Factory engineered, self-contained, capillary tube system using environmentally friendly (CFC free) 134A refrigerant.
- Extra large evaporator coil balanced with higher horsepower compressor and large condenser maintains 36°F to 38°F (2.2°C to 3.3°C), ideally suited for deli meats and cheeses.
- Forced-air refrigeration system; sealed, cast iron, self-lubricating evaporator fan motor and larger fan blades give True refrigerated display cases a more efficient low velocity, high volume airflow design.
- Condensing unit located behind removable panel in back of unit; slides out for easy cleaning and maintenance.

**CABINET CONSTRUCTION**

- Exterior - white laminate front and side panels. Color options available at no charge:



Walnut | Teak | Oak | Beige | Black | White  
All laminate ships separately from unit and is field installed. Stainless steel top.

- Interior - 300 series stainless steel sides and top, high impact plastic floor with coved corners.

- Insulation - entire cabinet structure is foamed-in-place using high density, CFC free, polyurethane insulation.
- Welded, heavy duty galvanized frame rail dipped in rust inhibiting enamel paint for corrosion protection inside and out.
- Frame rail fitted with leg levelers.

**CURVED FRONT DISPLAY GLASS**

- Insulated, double pane curved glass front and side panels provide extra large viewing area to maximize product presentation. Exterior pane is tempered for safety.
- Front glass tilts forward for easy cleaning.

**REAR DOORS**

- "Low-E", double pane thermal glass inserts.
- Each door fitted with 12" (305 mm) long molded plastic handle.
- Self-closing doors, efficient counter balanced weight system for smooth, even, positive closure. Sliding doors ride on stainless steel V-channel with stainless steel bearings. Doors fit within plastic channel frame.

**SHELVING**

- One (1) adjustable, cantilevered, lighted, stainless mezzanine shelf 46<sup>11/16</sup>" L x 14<sup>3/16</sup>" D (1186 mm x 361 mm).
- Shelf supports a maximum weight of 150 lbs. (69 kg).

**LIGHTING**

- Case is equipped with two (2) light sources for product display; one (1) shelf mounted and one (1) cabinet mounted. Fluorescent lamps are low UV emitting to enhance product appearance and increase shelf life.
- Safety shielded lighting tube assure longer, brighter, shadow-free product illumination.

**MODEL FEATURES**

- Evaporator is epoxy coated to eliminate the potential of corrosion.
- 5 amp exterior scale receptacle.
- Recessed exterior light switch and thermostat control.
- NSF-7 compliant for open food product.

**ELECTRICAL**

- Unit completely pre-wired at factory and ready for final connection to a 115/60/1 phase - 20 amp dedicated outlet. Cord and plug set included.



115/60/1  
NEMA-5-20R

**RECOMMENDED OPERATION CONDITIONS**

- TCGR models are designed to operate in an environment where temperature and humidity do not exceed 75°F (24°C) and 55% relative humidity.

**OPTIONAL FEATURES/ACCESSORIES**

Upcharge and lead times may apply.

- 6" (153 mm) standard legs.
- 6" (153 mm) seismic/flanged legs.
- 2 1/2" (64 mm) diameter castors.
- Custom exterior laminates, contact factory for details. See our website: [www.truemfg.com](http://www.truemfg.com) for the latest color offerings.
- Additional lighted stainless mezzanine shelves.
- Non-lighted stainless mezzanine shelves.
- Lighted white wire shelves.
- Non-lighted white wire shelves.
- Remote cabinets (condensing unit supplied by others; system comes standard with 404A expansion valve and requires R404A refrigerant). Consult factory technical service department for BTU information.

**PLAN VIEW**

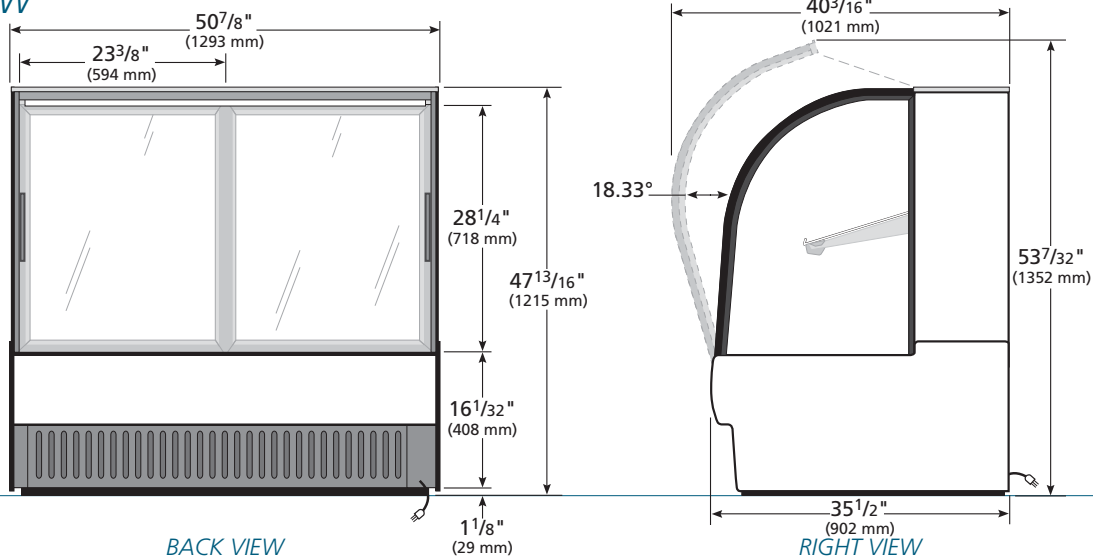

**WARRANTY**  
One year warranty on all parts & labor and an additional 4 year warranty on compressor. (U.S.A. only)

METRIC DIMENSIONS ROUNDED UP TO THE NEAREST WHOLE MILLIMETER  
SPECIFICATIONS SUBJECT TO CHANGE WITHOUT NOTICE

	Model	Elevation	Right	Plan	3D	Back
	TCGR-50-CD	TFD065E	TFD065S	TFD065P	TFD653	TFD055B

**TRUE FOOD SERVICE EQUIPMENT**