



TRUE FOOD SERVICE EQUIPMENT, INC.

2001 East Terra Lane • P.O. Box 970 • O'Fallon, Missouri 63366
 (636)240-2400 • Fax (636)272-2408 • (800)325-6152 • Intl Fax# (001)636-272-7546
 Parts Dept. (800)424-TRUE • Parts Dept. Fax# (636)272-9471 • www.truemfg.com

Project Name: _____

Location: _____

Item #: _____ Qty: _____

Model #: _____

A/A #

SIS #

Model:
TCGG-72-S

Display Case:
Curved Glass Deli Case



TCGG-72-S

- ▶ True's curved glass deli display case combines efficient, high volume merchandising and exceptional refrigeration with an elegant curved glass front for sophisticated presentation of deli products.
- ▶ High humidity gravity coil refrigeration system maintains 38°F to 40°F (3.3°C to 4.4°C) for the freshest display of meats, cheeses and deli products.
- ▶ Self-contained, environmentally friendly (CFC free) 134A refrigeration system.
- ▶ Cabinet is NSF-7 certified to hold open food product.
- ▶ Insulated double pane glass provides maximum insulation value for greater efficiency and energy savings. Both panes are tempered for safety.
- ▶ Two (2) adjustable, lighted, cantilevered PVC coated shelves.
- ▶ Low UV emitting fluorescent lighting system.
- ▶ All stainless steel interior and exterior.

ROUGH-IN DATA

Specifications subject to change without notice.
 Chart dimensions rounded up to the nearest 1/8" (millimeters rounded up to next whole number).

Model	Doors	Capacity (Cu. Ft.) (liters)	Shelves	Cabinet Dimensions (inches) (mm)			HP	Voltage	Amps	NEMA Config.	Cord Length (total ft.) (total m)	Crated Weight (lbs.) (kg)
				L	D†	H						
TCGG-72-S	2	37.1 1051	1	72 ¹ / ₈ 1832	35 ¹ / ₄ 896	47 ³ / ₄ 1213	3/4	115/60/1	16.0	5-20P	9 2.74	705 320

† Depth does not include 7/8" (23 mm) for rear door handles.



APPROVALS:

AVAILABLE AT:

Model:
TCGG-72-S

Display Case:
Curved Glass Deli Case



STANDARD FEATURES

DESIGN

- True's curved glass deli display case combines efficient, high volume merchandising and exceptional refrigeration with an elegant curved glass front for sophisticated presentation of deli products.
- Gravity coil refrigeration system guarantees the freshest display of meats, cheeses and deli products.

REFRIGERATION SYSTEM

- Factory engineered self-contained, capillary tube system using environmentally friendly (CFC free) 134A refrigerant.
- Extra large evaporator coil balanced with higher horsepower compressor and large condenser maintains 38°F to 40°F (3.3°C to 4.4°C).
- High humidity gravity coil refrigeration system. Ideally suited for deli meats, cheeses and salads.
- Condensing unit located behind panel in back of unit. Entire system slides out for easy cleaning and maintenance.
- Automatic defrost system; time-initiated, time terminated.

CABINET CONSTRUCTION

- Exterior - all stainless steel front, sides, back and top.
- Interior - all stainless steel sides and 300 series stainless steel floor with coved corners.
- Insulation - entire cabinet structure is foamed-in-place using high density, CFC free, polyurethane insulation.

- Welded, heavy duty galvanized frame rail. Dipped in rust inhibiting enamel paint for corrosion protection inside and out.
- Rail fitted with leg levelers.

CURVED FRONT DISPLAY GLASS

- Insulated double pane glass provides maximum insulation value for greater efficiency and energy savings. Both panes are tempered for safety.

DOORS

- "Low-E", double pane thermal glass insert with mitered plastic channel frame.
- Each door fitted with 12" (305 mm) long molded plastic handle.
- Self-closing doors, efficient counter balanced weight system for smooth, even, positive closure. Sliding doors ride on stainless steel V-Channel with stainless steel bearings. Doors fit within plastic channel frame.

SHELVING

- Two (2) adjustable, lighted, white heavy duty PVC coated wire shelves 66⁷/₈" L x 22⁵/₃₂" D (1699 mm x 563 mm). Shelving is cantilevered and angle can be adjusted to maximize presentation.

LIGHTING

- Cabinet is equipped with Three (3) light sources for maximum product display; Two (2) shelf mounted and One (1) cabinet mounted. Fluorescent lamps are low UV emitting to enhance product appearance and increase shelf life.

MODEL FEATURES

- Four (4) amp exterior scale receptacle.
- Evaporator is epoxy coated to eliminate the potential of corrosion.
- NSF compliant for open food product.

ELECTRICAL

- Unit completely pre-wired at factory and ready for final connection to a 115/60/1 phase - 20 amp dedicated outlet. Cord and plug set included.



115/60/1
NEMA-5-20R

RECOMMENDED OPERATION CONDITIONS

- TCGG models are designed to operate in an environment where temperature and humidity do not exceed 75°F (23.89°C) and 55% relative humidity.

OPTIONAL FEATURES/ACCESSORIES

Upcharge and lead times may apply.

- 6" (153 mm) standard legs.
- 6" (153 mm) seismic/flanged legs.
- 2¹/₂" (64 mm) diameter castors.
- Ratchet locks.
- Additional lighted shelves.
- Non-lighted shelves.
- Lighted stainless steel mezzanine shelves.
- Non-lighted stainless steel mezzanine shelves.
- Remote cabinets (condensing unit supplied by others; system comes standard with 404A expansion valve and requires R404A refrigerant). Consult factory technical service department for BTU information.

PLAN VIEW

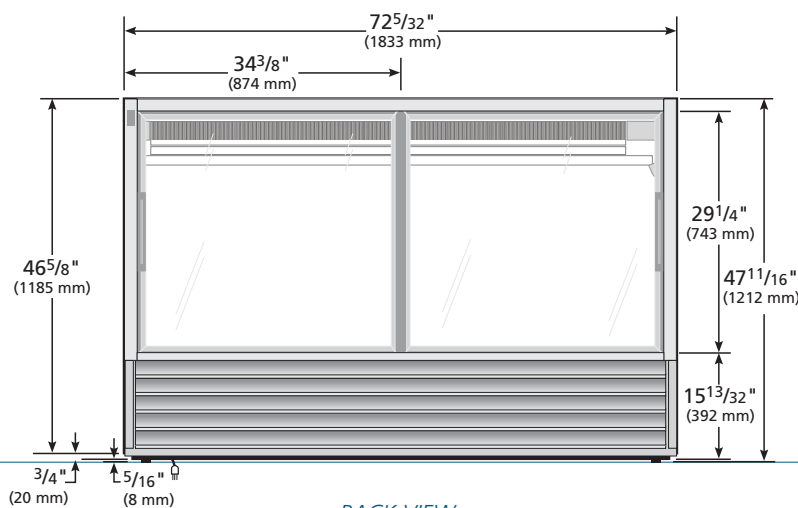

BACK VIEW

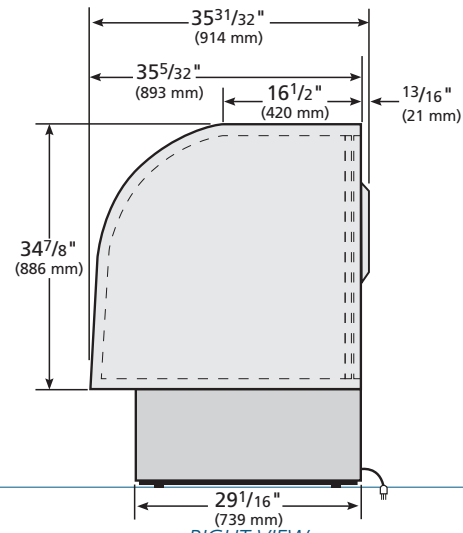

RIGHT VIEW

WARRANTY

One year warranty on all parts and labor and an additional 4 year warranty on compressor. (U.S.A. only)

METRIC DIMENSIONS ROUNDED UP TO THE NEAREST WHOLE MILLIMETER

SPECIFICATIONS SUBJECT TO CHANGE WITHOUT NOTICE



Model	Elevation	Right	Plan	3D	Back
TCGG-72-S	TFD057E	TFD057S	TFD057P	TFD0573	TFD057B

TRUE FOOD SERVICE EQUIPMENT

2001 East Terra Lane • P.O. Box 970 • O'Fallon, Missouri 63366 • (636)240-2400 • Fax (636)272-2408 • (800)325-6152 • Intl. Fax# (001)636-272-7546 • www.truemfg.com