



**TRUE FOOD SERVICE EQUIPMENT, INC.**

2001 East Terra Lane • P.O. Box 970 • O'Fallon, Missouri 63366  
 (636)240-2400 • Fax (636)272-2408 • (800)325-6152 • Intl Fax# (001)636-272-7546  
 Parts Dept. (800)424-TRUE • Parts Dept. Fax# (636)272-9471 • www.truemfg.com

Project Name: \_\_\_\_\_

A/A #

Location: \_\_\_\_\_

Item #: \_\_\_\_\_ Qty: \_\_\_\_\_

S/S #

Model #: \_\_\_\_\_

Model:  
**TCGD-50**

**Display Case:**  
*Curved Glass, Non-Refrigerated, "Dry" Bakery Case*



**TCGD-50**

- ▶ True's non-refrigerated "dry" bakery case combines efficient, high volume merchandising with an elegant curved glass front for sophisticated presentation of breads, desserts and pastries.
- ▶ Cabinet is NSF-2 certified to hold open food product.
- ▶ Single pane curved glass front and side panels provide extra large viewing area to maximize bakery product presentation. Front glass tilts forward for easy cleaning.
- ▶ Three (3) adjustable PVC coated shelves.
- ▶ Special "brown bulb" lighting provides balanced color spectrum that enhances the appearance of bakery products.
- ▶ Exterior front and sides standard with white laminated panels, five additional color options available at no charge. Stainless steel top.
- ▶ White aluminum interior sides and top. High impact plastic floor with coved corners.

**ROUGH-IN DATA**

Specifications subject to change without notice.  
 Chart dimensions rounded up to the nearest 1/8" (millimeters rounded up to next whole number).

Model	Doors	Capacity (Cu. Ft.) (liters)	Shelves	Cabinet Dimensions (inches) (mm)			Voltage	Amps	Crated Weight (lbs.) (kg)
				L	D†	H			
TCGD-50	2	23.8 674	3	50 <sup>7</sup> / <sub>8</sub> 1293	35 <sup>1</sup> / <sub>2</sub> 902	47 <sup>7</sup> / <sub>8</sub> 1217	115/60/1 230-240/50/1	6.0 0.5	445 202

† Depth does not include 3/4" (18mm) for rear door handles.



APPROVALS:

AVAILABLE AT:

Model:  
**TCGD-50**

**Display Case:**  
Curved Glass, Non-Refrigerated, "Dry" Bakery Case



## STANDARD FEATURES

### DESIGN

- True's "dry" display case combines efficient, high volume merchandising with an elegant curved glass front for sophisticated presentation of breads, desserts and pastries.
- Designed to provide an attractive companion to our forced-air refrigerated display case.

### CABINET CONSTRUCTION

- Exterior - white laminate front and side panels. Color options available at no charge:

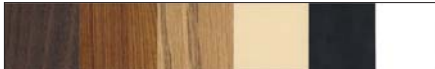

Walnut | Teak | Oak | Beige | Black | White  
All laminates and stainless option ship separately from unit and are field installed. Stainless steel top. Black front grill and trim. Template kit available for field customization of laminate.

- Interior - NSF approved white aluminum sides and top; high impact plastic floor with coved corners.
- Welded, heavy duty galvanized frame rail dipped in rust inhibiting enamel paint for corrosion protection inside and out.
- Frame rail fitted with leg levelers.

### CURVED FRONT DISPLAY GLASS

- Single pane curved glass front and side panels provide extra large viewing area to maximize bakery product presentation. Glass is tempered for safety.

- Front glass tilts forward for easy cleaning.

### REAR DOORS

- "Low-E", double pane thermal glass rear door inserts with mitered plastic channel frame.
- Each door fitted with 12" (305 mm) long molded plastic handle.
- Self-closing doors, efficient counter balanced weight system for smooth, even, positive closure. Sliding doors ride on stainless steel V-Channel with stainless steel bearings. Doors fit within plastic channel frame.

### SHELVING

- Three (3) adjustable, heavy duty PVC coated wire shelves 44<sup>3</sup>/<sub>8</sub>" L x 22<sup>5</sup>/<sub>32</sub>" D (1128 mm x 563 mm). Shelving system is cantilevered and angle can be adjusted to maximize presentation.
- Each shelf supports a maximum weight of 150 lbs. (69 kg).

### PAN CAPACITY

- Cabinet holds eight (8) 18" L x 26" D (458 mm x 661 mm) display pans (2 per level) and four (4) 9" L x 26" D (229 mm x 661 mm) display pans (1 per level). Pans supplied by others.

### LIGHTING

- Case is equipped with four (4) light sources for maximum product display; three (3) shelf mounted and one (1) cabinet mounted. Special "brown bulb" lighting provides balanced color spectrum that enhances the appearance of bakery products.

- Safety shielded lighting tubes assure longer, brighter, shadow-free product illumination.

### MODEL FEATURES

- 5 Amp exterior scale receptacle.
- Recessed exterior light switch.
- NSF-2 compliant for open food product.

### ELECTRICAL

- Unit comes with 4 feed wires (including ground) to be hardwired at installation site to a 115/60/1 phase, 15 amp dedicated outlet.

### OPTIONAL FEATURES/ACCESSORIES

Upcharge and lead times may apply.

- 230 - 240V / 50 Hz.
- 6" (153 mm) standard legs.
- 6" (153 mm) seismic/flanged legs.
- 2<sup>1</sup>/<sub>2</sub>" (64 mm) diameter castors [note: castors can not be installed on units that are hard wired, optional 12" (305mm) power cord must be factory installed].
- 12" (305 mm) cord set (factory installed). Exterior scale receptacle will not be included with this option.
- Custom exterior laminates, contact factory for details. See our website: [www.truemfg.com](http://www.truemfg.com) for the latest color offerings.
- Stainless steel exterior (field installed).
- Mirrored interior ends with laminate exterior.
- Additional lighted shelves.
- Additional non-lighted shelves.

## PLAN VIEW

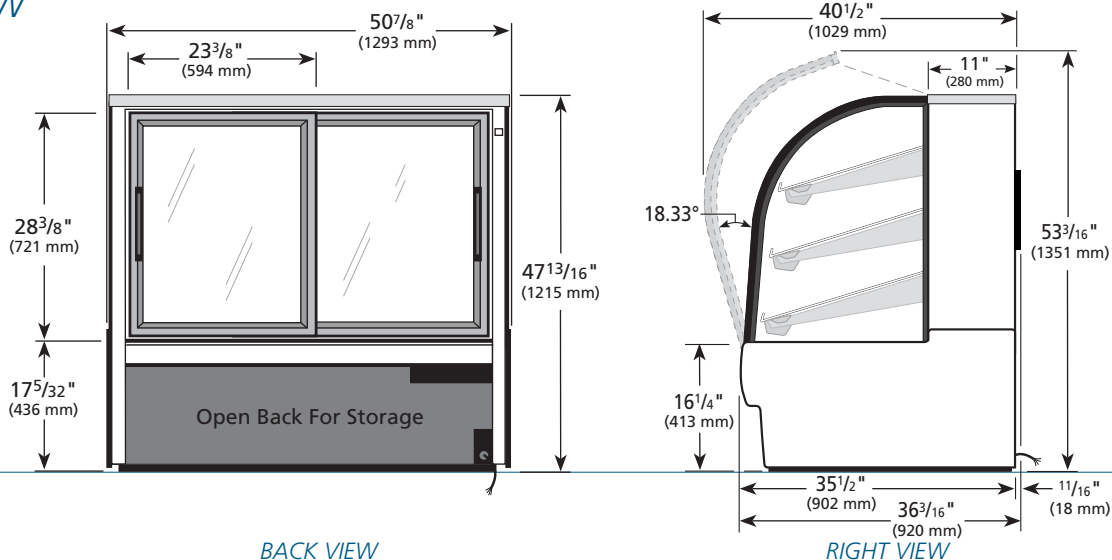

**WARRANTY**  
One year warranty on all parts & labor.

METRIC DIMENSIONS ROUNDED UP TO THE NEAREST WHOLE MILLIMETER  
SPECIFICATIONS SUBJECT TO CHANGE WITHOUT NOTICE



Model	Elevation	Right	Plan	3D	Back
TCGD-50	TFD056E	TFD055S	TFD056P	TFD0563	TFD056B

## TRUE FOOD SERVICE EQUIPMENT