



TRUE FOOD SERVICE EQUIPMENT, INC.

2001 East Terra Lane • P.O. Box 970 • O'Fallon, Missouri 63366
 (636)240-2400 • Fax (636)272-2408 • (800)325-6152 • Intl Fax# (001)636-272-7546
 Parts Dept. (800)424-TRUE • Parts Dept. Fax# (636)272-9471 • www.truemfg.com

Project Name: _____

A/A #

Location: _____

Item #: _____ Qty: _____

SIS #

Model #: _____

Model:
TCGD-31

Display Case:
Curved Glass Non-Refrigerated "Dry" Bakery Display Case



TCGD-31

- ▶ True's non-refrigerated "dry" bakery display case combines efficient, high volume merchandising with an elegant curved glass front for sophisticated presentation of breads, desserts and pastries.
- ▶ Cabinet is NDF-2 certified to hold open food product.
- ▶ Single pane curved glass front and side panels provide extra large viewing area to maximize bakery product presentation. Front glass tilts forward for easy cleaning.
- ▶ Three (3) adjustable PVC coated shelves.
- ▶ Special "brown bulb" lighting provides balanced color spectrum that enhances the appearance of bakery products.
- ▶ Exterior front and sides standard with white laminated panels, five additional color options available at no charge. Stainless steel top.
- ▶ White aluminum interior sides and top. High impact plastic floor with coved corners.

ROUGH-IN DATA

Specifications subject to change without notice.
 Chart dimensions rounded up to the nearest 1/8" (millimeters rounded up to next whole number).

Model	Rear Doors	Capacity (Cu. Ft.) (liters)	Shelves	Cabinet Dimensions (inches) (mm)			Voltage	Amps	Crated Weight (lbs.) (kg)
				L	D†	H			
TCGD-31	2	14 397	3	31 7/8 810	38 1/8 969	47 7/8 1217	115/60/1	0.4	340 155

† Depth does not include 1 3/8" (35mm) for rear door handles.

	<p>APPROVALS:</p>	<p>AVAILABLE AT:</p>
<p>3/07 Printed in U.S.A.</p>		

Model:

TCGD-31

Display Case:

Curved Glass Non-Refrigeated "Dry" Bakery Display Case



STANDARD FEATURES

DESIGN

- True's non-refrigerated "dry" bakery display case combines efficient, high volume merchandising with an elegant curved glass front for sophisticated presentation of breads, desserts and pastries.
- Designed to provide an attractive companion to our forced-air refrigerated display case.

CABINET CONSTRUCTION

- Exterior - white laminate front and side panels. Color options available at no charge:

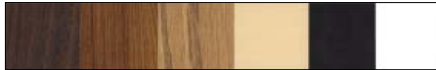

Walnut | Teak | Oak | Beige | Black | White

All laminate ships separately from unit and is field installed. Stainless steel top. Black front grill and trim. Template kit available at no charge for field customization of laminate.

- Interior - NSF approved white aluminum sides and top; high impact plastic floor with coved corners.
- Welded, heavy duty galvanized frame rail dipped in rust inhibiting enamel paint for corrosion protection inside and out.
- Frame rail fitted with leg levelers.

CURVED FRONT DISPLAY GLASS

- Single pane curved glass front and side panels provide extra large viewing area to maximize bakery product presentation. Glass is tempered for safety.

- Front glass tilts forward for easy cleaning.

REAR DOORS

- "Low-E", double pane thermal glass door assembly with extruded aluminum frame.
- Each door fitted with 12" (305 mm) extruded handle.
- Self-closing doors. Positive seal, torsion type closing system.
- Magnetic door gasket of one piece construction, removable without tools for ease of cleaning.

SHELVING

- Three (3) adjustable, heavy duty PVC coated wire shelves 24³/₈" L x 22⁵/₃₂" D (620 mm x 563 mm). Shelving system is cantilevered and angle can be adjusted to maximize presentation.
- Shelf supports a maximum weight of 150 lbs. (69 kg).

PAN CAPACITY

- Cabinet holds four (4) 18" L x 26" D (458 mm x 661 mm) display pans (1 per level) and four (4) 9" L x 26" D (229 mm x 661 mm) display pans (1 per level). Pans supplied by others.

LIGHTING

- Cabinet is equipped with four (4) light sources for maximum product display; three (3) shelf mounted and one (1) cabinet mounted. Special "brown bulb" lighting provides balanced color spectrum that enhances the appearance of bakery products.

- Safety shielded lighting tube assure longer, brighter, shadow-free product illumination.

MODEL FEATURES

- Recessed exterior light switch.
- NSF-2 compliant for open food product.

ELECTRICAL

- Unit comes with 4 feed wires (including ground) to be hardwired at installation site to a 115/60/1 phase - 15 amp dedicated outlet.

OPTIONAL FEATURES/ACCESSORIES

Upcharge and lead times may apply.

- 6" (153 mm) standard legs.
- 6" (153 mm) seismic/flanged legs.
- 2¹/₂" (64 mm) diameter castors [NOTE: castors can not be installed on units that are hardwired, optional 12" (305 mm) power cord must be factory installed].
- 12" (305 mm) cord set (factory installed).
- Custom exterior laminates, contact factory for details. See our website: www.truemfg.com for the latest color offerings.
- Stainless steel exterior.
- Mirrored interior ends with laminate exterior.
- Additional lighted shelves.
- Additional non-lighted shelves.

PLAN VIEW

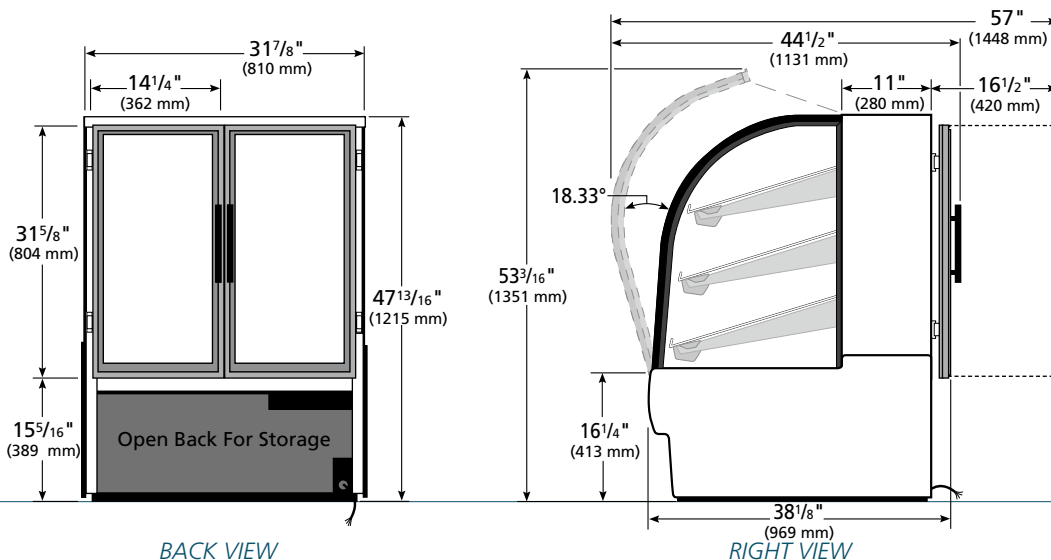

WARRANTY
One year warranty on all parts & labor.

METRIC DIMENSIONS ROUNDED UP TO THE NEAREST WHOLE MILLIMETER
SPECIFICATIONS SUBJECT TO CHANGE WITHOUT NOTICE



Model	Elevation	Right	Plan	3D	Back
TCGD-31	TFD075E	TFD075S	TFD080P	TFD0803	TFD080B

TRUE FOOD SERVICE EQUIPMENT