



TRUE FOOD SERVICE EQUIPMENT, INC.

2001 East Terra Lane • P.O. Box 970 • O'Fallon, Missouri 63366
(636)240-2400 • Fax (636)272-2408 • (800)325-6152 • Intl Fax# (001)636-272-7546
Parts Dept. (800)424-TRUE • Parts Dept. Fax# (636)272-9471 • www.truemfg.com

Project Name: _____

A/A #

Location: _____

Item #: _____ Qty: _____

SIS #

Model #: _____

Model:
TAC-48

Vertical Air Curtain: Refrigerator



TAC-48

- ▶ True's air curtain merchandisers are designed with enduring quality that protects your long term investment.
- ▶ Designed using the highest quality materials and components to provide the user with colder product temperatures and lower utility costs in an attractive merchandiser that brilliantly displays pre-packaged food and beverages.
- ▶ Large, open front allows easy access to display levels and places maximum attention on merchandising.
- ▶ Oversized, factory balanced, refrigeration system holds 33°F to 38°F (.5°C to 3.3°C).
- ▶ Exclusive, reversing condenser fan motor(s) reduce maintenance costs and optimize cabinet performance.
- ▶ Durable and permanent non-peel or chip white vinyl exterior with white aluminum interior and 300 series stainless steel floor and deck pans.
- ▶ Adjustable, heavy duty PVC coated shelves.
- ▶ Entire cabinet structure is foamed-in-place using high density, CFC free, polyurethane insulation.

ROUGH-IN DATA

Specifications subject to change without notice.

Chart dimensions rounded up to the nearest 1/8" (millimeters rounded up to next whole number).

Model	Capacity (Cu. Ft.) (liters)	Shelves	Cabinet Dimensions (inches) (mm)			HP	Voltage	Amps	NEMA Config.	Cord Length (total ft.) (total m)	Crated Weight (lbs.) (kg)
			L	D	H						
TAC-48	34	4	48	30 ¹ / ₈	80 ⁵ / ₈	1	208-230/60/1	12.0	6-15P ▲	6.5	475
	963		1220	766	2048	1	230-240/50/1	9.0		1.98	216

▲ Plug type varies by country.



APPROVALS:

AVAILABLE AT:

Model:
TAC-48

Vertical Air Curtain: Refrigerator



STANDARD FEATURES

DESIGN

- Designed using the highest quality materials and components to provide the user with colder product temperatures and lower utility costs in an attractive merchandiser that brilliantly displays pre-packaged food and beverages.

REFRIGERATION SYSTEM

- Factory engineered, self-contained, capillary tube system using environmentally friendly (CFC free) R404A refrigerant.
- Time-initiated, time-terminated off cycle defrost system.
- Extra large evaporator coil and condenser balanced with higher horsepower compressor; maintains cabinet temperatures of 33°F to 38°F (.5°C to 3.3°C) for the best in food preservation.
- Sealed, cast iron, self-lubricating evaporator fan motor(s).
- Bottom mounted condensing unit positioned for easy maintenance.
- Exclusive reversing condenser fan motor(s). Fan motor(s) reverse during defrost off cycles to help keep condenser coil free from dirt, dust and debris. Keeping coils clean optimizes the unit's performance providing colder holding temperatures and increased energy efficiency. Regularly scheduled thorough cleaning of coils still recommended.

CABINET CONSTRUCTION

- Exterior - durable and permanent non-peel or chip white vinyl front and sides with matching white aluminum back.
- Plexiglass lower front panel; durable and break resistant.
- Interior - attractive, NSF approved, white aluminum liner. 300 series stainless steel interior floor and deck pans.
- Insulation - entire cabinet structure is foamed-in-place using high density, CFC free, polyurethane insulation.
- Welded, heavy duty galvanized frame rail dipped in rust inhibiting enamel paint for corrosion protection inside and out.

- Frame rail fitted with leg levelers.
- Illuminated exterior sign panel. Variety of sign options available.

SHELVING

- Four (4) adjustable, heavy duty PVC coated wire shelves 44"L x 16³/₄"D (1118 mm x 426 mm). Four (4) chrome plated shelf clips included per shelf.
- Shelf support pilasters made of same material as cabinet interior; shelves are adjustable on 1/2" (13 mm) increments.

LIGHTING

- Fluorescent interior lighting, safety shielded.
- T8 bulbs and electronic ballast; provides better illumination of product and increased energy efficiency.

MODEL FEATURES

- Perforated interior back wall for more efficient airflow.
- Listed under NSF-7 for the storage and/or display of packaged or bottled product.

ELECTRICAL

- Unit completely pre-wired at factory and ready for final connection to a 208-230V / 60 Hz single phase 15 amp dedicated outlet. Cord and plug set included.



208-230/60/1
NEMA-6-15R

RECOMMENDED OPERATION CONDITIONS

- Designed to operate in an environment where temperature and humidity do not exceed 75°F (24°C) and 55% relative humidity.
- Unit **should not be installed** near HVAC vents, fans or doorways that will disrupt the air curtain and compromise the function of the cabinet. Unit should not be installed in direct sunlight.

- Model will run most efficiently when completely loaded with product.
- Drain plumbing hookup recommended. Condensate pan heater kit available if there is no access to drain plumbing. Condensate pan heater must be field installed and requires a separate 15 amp, 120V circuit.
- Please be advised air curtain models are substantially louder than standard refrigeration models.

OPTIONAL FEATURES/ACCESSORIES

Upcharge and lead times may apply.

- 230 - 240V / 50 Hz.
- 2 1/2" (64mm) diameter castors.
- Variety of sign panels - see our website for the latest color and sign offerings.
- Black exterior.
- Stainless steel exterior.
- Black interior liner with black shelves.
- Additional shelves.
- White cantilevered shelves.
- Stainless steel cantilevered shelves.
- Pricing strips.
- Night shade.
- Night cover.
- Vandal cover.
- White locking security cover. Standard with flat sign panel.
- Silver locking security cover. Standard with flat sign panel.
- Black/bronze locking security cover. Standard with flat sign panel.
- Condensate pan heater/brackets kit. Requires separate 15 amp, 120V dedicated circuit. Cannot be hard wired into cabinet.
- Condensate pump kit.
- Remote cabinets (condensing unit supplied by others; system comes standard with 404A expansion valve and requires R404A refrigerant). Consult factory technical service department for BTU information.

PLAN VIEW

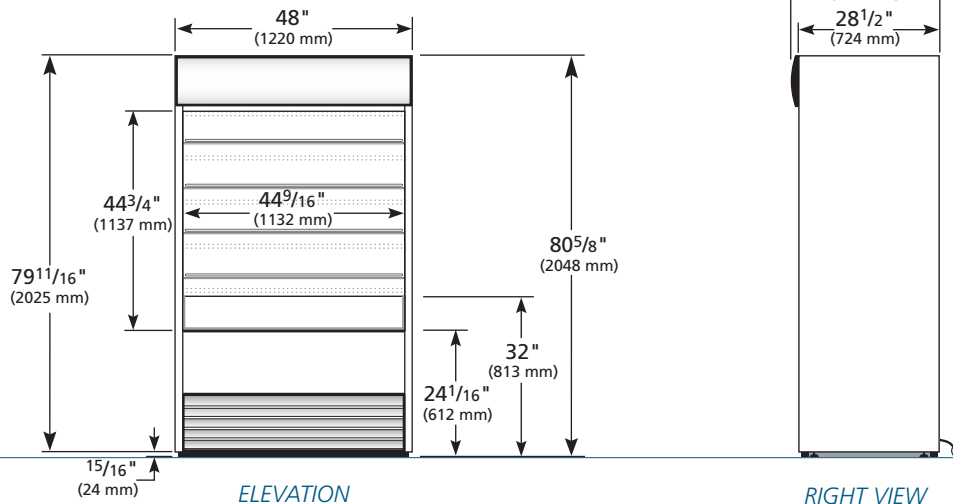

WARRANTY

One year warranty on all parts & labor and an additional 4 year warranty on compressor. (U.S.A. only)

METRIC DIMENSIONS ROUNDED UP TO THE NEAREST WHOLE MILLIMETER
SPECIFICATIONS SUBJECT TO CHANGE WITHOUT NOTICE



Model	Elevation	Right	Plan	3D
TAC-48	TFD025E	TFD025S	TFD025P	TFD0253

TRUE FOOD SERVICE EQUIPMENT

2001 East Terra Lane • P.O. Box 970 • O'Fallon, Missouri 63366 • (636)240-2400 • Fax (636)272-2408 • (800)325-6152 • Intl. Fax# (001)636-272-7546 • www.truemfg.com