



**TRUE FOOD SERVICE  
EQUIPMENT, INC.**

2001 East Terra Lane • P.O. Box 970 • O'Fallon, Missouri 63366  
(636)240-2400 • Fax (636)272-2408 • (800)325-6152 • Intl Fax# (001)636-272-7546  
Parts Dept. (800)424-TRUE • Parts Dept. Fax# (636)272-9471 • www.truemfg.com

Project Name: \_\_\_\_\_

Location: \_\_\_\_\_

Item #: \_\_\_\_\_ Qty: \_\_\_\_\_

Model #: \_\_\_\_\_

AIA #

SIS #

Model:  
**TAC-14GS**

**Vertical Air Curtain:**  
*Glass Sided Refrigerator*



## TAC-14GS

- ▶ True's air curtain merchandisers are designed with enduring quality that protects your long term investment.
- ▶ Designed using the highest quality materials and components to provide the user with colder product temperatures and lower utility costs in an attractive merchandiser that brilliantly displays pre-packaged food and beverages.
- ▶ Large, open front allows easy access to display levels and places maximum attention on merchandising.
- ▶ Oversized, factory balanced, refrigeration system holds 33°F to 38°F (.5°C to 3.3°C).
- ▶ Exclusive, reversing condenser fan motor(s) reduces maintenance costs and optimize cabinet performance.
- ▶ Durable and permanent non-peel or chip black vinyl exterior with white aluminum interior and 300 series stainless steel floor and deck pans.
- ▶ Adjustable, heavy duty PVC coated shelves.
- ▶ Entire cabinet structure is foamed-in-place using high density, CFC free, polyurethane insulation.

## ROUGH-IN DATA

Specifications subject to change without notice.  
Chart dimensions rounded up to the nearest 1/8" (millimeters rounded up to next whole number).

Model	Capacity (Cu. Ft.) (liters)	Shelves	Cabinet Dimensions (inches) (mm)			HP	Voltage	Amps	NEMA Config.	Cord Length (total ft.) (total m)	Crated Weight (lbs.) (kg)
			L	D	H						
TAC-14GS	16.2	3	30 <sup>1</sup> / <sub>4</sub>	30 <sup>3</sup> / <sub>8</sub>	56 <sup>3</sup> / <sub>8</sub>	1/2	115/60/1	10.9	5-15P	6 <sup>1</sup> / <sub>2</sub>	280
	459		769	772	1432	1/2	230-240/50/1	4.5			

▲ Plug type varies by country.



7/07

Printed in U.S.A.

APPROVALS:

AVAILABLE AT:

Model:  
**TAC-14GS**

**Vertical Air Curtain:**  
*Glass Sided Refrigerator*



**STANDARD FEATURES**

**DESIGN**

- Designed using the highest quality materials and components to provide the user with colder product temperatures and lower utility costs in an attractive merchandiser that brilliantly displays pre-packaged food and beverages.

**REFRIGERATION SYSTEM**

- Factory engineered, self-contained, capillary tube system using environmentally friendly (CFC free) R134A refrigerant.
- Time initiated, time terminated off cycle defrost system.
- Extra large evaporator coil and condenser balanced with higher horsepower compressor; maintains cabinet temperatures of 33°F to 38°F (.5°C to 3.3°C) for the best in food preservation.
- Sealed, cast iron, self-lubricating evaporator fan motor(s).
- Bottom mounted condensing unit positioned for easy maintenance.
- Exclusive reversing condenser fan motor(s). Fan motor(s) reverse during defrost off cycles to help keep condenser coil free from dirt, dust and debris. Keeping coils clean optimizes the unit's performance providing colder holding temperatures and increased energy efficiency. Regularly scheduled thorough cleaning of coils still recommended.

**CABINET CONSTRUCTION**

- Exterior - durable and permanent non-peel or chip black vinyl front and sides with matching black aluminum back. Attractive, stainless steel contoured front accent panel.
- Plexiglass lower front and side panels. Durable and break resistant maximizes product visibility.

- Interior - attractive, NSF approved, white aluminum liner. 300 series stainless steel interior floor and deck pans.
- Insulation - entire cabinet structure is foamed-in-place using high density, CFC free, polyurethane insulation.
- Welded, heavy duty galvanized frame rail dipped in rust inhibiting enamel paint for corrosion protection inside and out.
- Frame rail fitted with leg levelers.
- Illuminated exterior sign panel. Variety of sign options available.

**SHELVING**

- Three (3) adjustable, heavy duty PVC coated wire shelves 25<sup>11</sup>/<sub>16</sub>" L x 15<sup>3</sup>/<sub>8</sub>" D (653 mm x 391 mm). Four (4) chrome plated shelf clips included per shelf.
- Shelf support pilasters made of same material as cabinet interior; shelves are adjustable on <sup>1</sup>/<sub>2</sub>" (13 mm) increments.

**LIGHTING**

- Fluorescent interior lighting, safety shielded.
- T8 bulbs and electronic ballast; provides better illumination of product and increased energy efficiency.

**MODEL FEATURES**

- Perforated interior back wall for exceptional airflow.
- Listed under NSF-7 for the storage and/or display of packaged or bottled product.

**ELECTRICAL**

- Unit completely pre-wired at factory and ready for final connection to a 115V / 60 Hz single phase 15 amp dedicated outlet. Cord and plug set included.



115/60/1  
NEMA-5-15R

**RECOMMENDED OPERATION CONDITIONS**

- Designed to operate in an environment where temperature and humidity do not exceed 75°F (24°C) and 55% relative humidity.
- Unit **should not be installed** near HVAC vents, fans or doorways that will disrupt the air curtain and compromise the function of the cabinet. Unit should not be installed in direct sunlight.
- Model will run most efficiently when completely loaded with product.
- Drain plumbing hookup recommended.

**OPTIONAL FEATURES/ACCESSORIES**

- Upcharge and lead time may apply.
- 230 - 240V / 50 Hz.
  - 4" (102 mm) diameter castors (set of 4)
  - Variety of sign panels - see our website for the latest color and sign offerings.
  - White exterior.
  - Stainless steel exterior.
  - Black interior liner with black shelves.
  - Additional shelves.
  - TrueTrac 20 oz. (592 mL) organizers.
  - TrueTrac 8 oz. (237 mL) and 10 oz. (296 mL) milk organizers.
  - Pricing strips.
  - Remote cabinets (condensing unit supplied by others; system comes standard with 404A expansion valve and requires R404A refrigerant), consult factory technical service department for BTU information.

**PLAN VIEW**

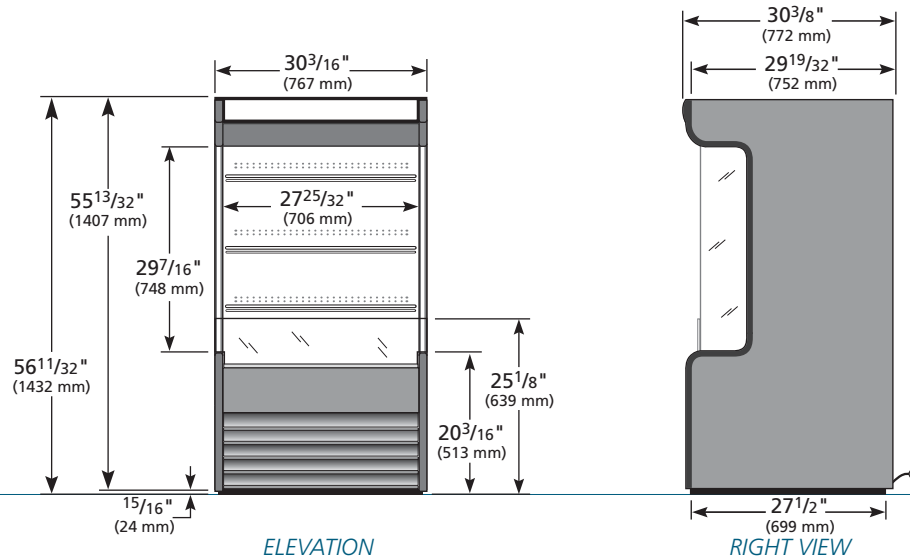

**WARRANTY**

One year warranty on all parts and labor and an additional 4 year warranty on compressor. (U.S.A. only)

METRIC DIMENSIONS ROUNDED UP TO THE NEAREST WHOLE MILLIMETER

SPECIFICATIONS SUBJECT TO CHANGE WITHOUT NOTICE



Model	Elevation	Right	Plan	3D
TAC-14GS				

**TRUE FOOD SERVICE EQUIPMENT**