



**TRUE FOOD SERVICE EQUIPMENT, INC.**

2001 East Terra Lane • P.O. Box 970 • O'Fallon, Missouri 63366  
 (636)240-2400 • Fax (636)272-2408 • (800)325-6152 • Intl Fax# (001)636-272-7546  
 Parts Dept. (800)424-TRUE • Parts Dept. Fax# (636)272-9471 • www.truemfg.com

Project Name: \_\_\_\_\_

Location: \_\_\_\_\_

Item #: \_\_\_\_\_ Qty: \_\_\_\_\_

Model #: \_\_\_\_\_

AIA #

SIS #

Model:  
**TA1RRI89-1S**

**TA Series:**  
*Roll-In Solid Door Refrigerator*



**TA1RRI89-1S**

- ▶ Designed using the highest quality materials and components to provide the user with colder product temperatures, lower utility costs and exceptional food safety.
- ▶ Oversized, factory balanced, refrigeration system holds 33°F to 38°F (.5°C to 3.3°C) for the best in food preservation.
- ▶ 300 series stainless steel exterior front, sides, back and bottom. The very finest stainless with higher tensile strength for fewer dents and scratches.
- ▶ NSF approved, white aluminum interior sides and back liner. 300 series stainless steel door liner and floor with coved corners.
- ▶ Designed to accept roll-in racks (inboard castors) with a maximum dimension of 27" L x 29" D x 72" H (686 mm x 737 mm x 1829 mm)(supplied by others). One (1) heavy gauge stainless steel ramp standard.
- ▶ Three (3) lifetime guaranteed, cam-lift hinges. Full 180° open capability with a stay open feature at 120°.
- ▶ Lifetime guaranteed recessed door handle.
- ▶ Entire cabinet structure and solid door are foamed-in-place using high density, CFC free, polyurethane insulation.

**ROUGH-IN DATA**

Specifications subject to change without notice.

Chart dimensions rounded up to the nearest 1/8" (millimeters rounded up to next whole number).

Model	Doors	Capacity (Cu. Ft.) (liters)	Cabinet Dimensions (inches) (mm)			HP	Voltage	Amps	NEMA Config.	Cord Length (total ft.) (total m)	Crated Weight (lbs.) (kg)
			L	D <sup>†</sup>	H*						
TA1RRI89-1S	1	38 1076	35 889	34 1/2 877	88 3/4 2255	1/3	115/60/1	8.9	5-15P	9 2.74	485 220

† Depth does not include 4 1/4" (108 mm) for ramp.

\* Height does not include 1" (26 mm) for system mechanical components.

8/07 Printed in U.S.A.

APPROVALS:

AVAILABLE AT:

Model:

**TA1RRI89-1S**

**TA Series:**

*Roll-In Solid Door  
Refrigerator*



## STANDARD FEATURES

### DESIGN

- True's solid door roll-in's are designed with enduring quality that protects your long term investment.
- Designed using the highest quality materials and components to provide the user with colder product temperatures, lower utility costs and exceptional food safety.

### REFRIGERATION SYSTEM

- Factory engineered, self-contained, capillary tube system using environmentally friendly (CFC free) 134A refrigerant.
- Extra large evaporator coil balanced with higher horsepower compressor and large condenser maintains cabinet temperatures of 33°F to 38°F (.5°C to 3.3°C) for the best in food preservation.
- Sealed, cast iron, self-lubricating evaporator fan motor(s) and larger fan blades give True roll-in's a more efficient low velocity, high volume airflow design. This unique design ensures faster temperature recovery and shorter run times in the busiest of foodservice environments.
- Top mounted refrigeration system with evaporator positioned out of food zone to maximize capacity.
- Hot gas condensate for energy efficiency.

### CABINET CONSTRUCTION

- Exterior - 300 series stainless steel door, front, sides, back and bottom.
- Interior - NSF approved white aluminum side walls and back liner. 300 series stainless steel floor with coved corners.
- Insulation - entire cabinet structure and solid door are foamed-in-place using high density, CFC free, polyurethane insulation.
- One (1) heavy gauge stainless steel ramp.
- Designed to accept roll-in racks (inboard castors) with a maximum dimension of 27"L x 29"D x 72"H (686 mm x 737 mm x 1829 mm).

### DOOR

- 300 series stainless steel exterior and liner. Door opens within cabinet dimension.
- Door lock standard.
- Lifetime guaranteed recessed door handle. Door fitted with 12" (305 mm) long recessed handle that is foamed-in-place with a sheet metal interlock to ensure permanent attachment.
- Wiper gasket for positive seal, reversible.
- Three (3) lifetime guaranteed, cam-lift hinges. Full 180° open capability with a stay open feature at 120°.
- Magnetic door gasket of one piece construction, removable without tools for ease of cleaning.
- Door is field reversible.

### LIGHTING

- Incandescent interior lighting, safety shielded.

### MODEL FEATURES

- Exterior digital temperature display, available with either °F or °C.
- Evaporator is epoxy coated to eliminate the potential of corrosion.
- Interior bumpers protect cabinet walls from abuse caused by roll-in carts.
- NSF-7 compliant for open food product.

### ELECTRICAL

- Unit completely pre-wired at factory and ready for final connection to a 115/60/1 phase - 15 amp dedicated outlet. Cord and plug set included.



115/60/1  
NEMA-5-15R

### OPTIONAL FEATURES/ACCESSORIES

Upcharge and lead times may apply.

- Metal door handle (factory installed).
- Electronic temperature control (factory installed).
- Correctional facilities options.
- Remote cabinets (condensing unit supplied by others; system comes standard with 404A expansion valve and requires R404A refrigerant). Consult factory technical service department for BTU information.

## PLAN VIEW

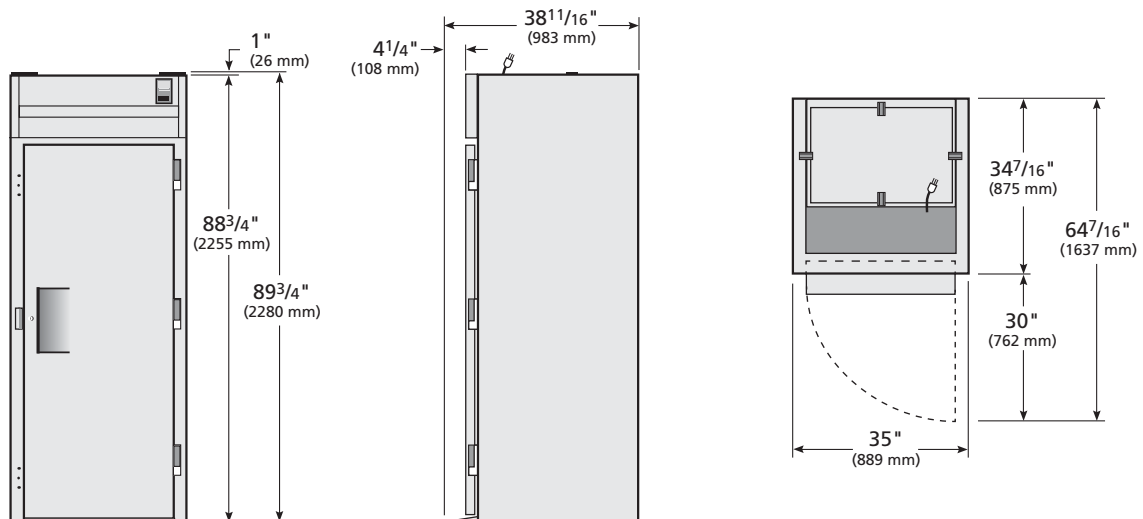

ELEVATION

RIGHT VIEW

PLAN VIEW

### WARRANTY

One year warranty on all parts and labor and an additional 4 year warranty on compressor. (U.S.A. only)

METRIC DIMENSIONS ROUNDED UP TO THE NEAREST WHOLE MILLIMETER

SPECIFICATIONS SUBJECT TO CHANGE WITHOUT NOTICE



Model	Elevation	Right	Plan	3D
TA1RRI89-1S	TFQY91E	TFQY83S	TFQY51P	TFQX513

## TRUE FOOD SERVICE EQUIPMENT

2001 East Terra Lane • P.O. Box 970 • O'Fallon, Missouri 63366 • (636)240-2400 • Fax (636)272-2408 • (800)325-6152 • Intl. Fax# (001)636-272-7546 • www.truemfg.com