



# TRUE FOOD SERVICE EQUIPMENT, INC.

St. Charles Industrial Center • P.O. Box 970 • O'Fallon, Missouri 63366  
(636)240-2400 • FAX (636)272-2408 • (800)325-6152 • www.truemfg.com  
Parts Dept. (800)424-TRUE • Parts Dept. FAX# (636)272-9471

Project Name: \_\_\_\_\_

Location: \_\_\_\_\_

Item #: \_\_\_\_\_ Qty: \_\_\_\_\_

Model #: \_\_\_\_\_

A/A #

SIS #

Model:  
**TA1HRI-1S**

## TA Specification Series: *Roll-In Solid Door Heated Cabinet*



### TA1HRI-1S

- ▶ Provides cabinet holding temperature of 80°F to 180°F (26.67°C to 82.22°C).
- ▶ Internal fan provides low velocity, forced-air heat distribution to assure even temperatures throughout the cabinet.
- ▶ (2) stainless steel 1000 watt finned tube heating elements per section for uniform generation of electric heat. Cabinet comes with a total of 2000 watts.
- ▶ 300 series stainless steel exterior front, sides, back and bottom. The very finest stainless; higher tensile strength for fewer dents and scratches.
- ▶ Anodized aluminum interior cabinet liner. 300 series stainless steel door liner and floor with coved corners.
- ▶ (3) lifetime guaranteed, cam-lift hinges per door. Full 180 degree open capability with a stay open feature at 120 degrees.
- ▶ Designed to accept roll-in racks (inboard castors) with a maximum dimensions of 27" L x 29"D x 66"H (686 mm x 737 mm x 1677 mm). (1) heavy gauge stainless steel ramp standard per door.
- ▶ Entire cabinet structure and solid door is foamed-in-place using high density, CFC free, polyurethane insulation.

### ROUGH-IN DATA

Specifications subject to change without notice.  
Chart dimensions rounded up to the nearest 1/8" (millimeters rounded up to next whole number).

Model	Solid Doors	Capacity (Cu. Ft.) (liters)	Cabinet Dimensions (inches) (mm)			Watts	Volts	Amps	NEMA Config.	Cord Length (total ft.) (total m)	Crated Weight (lbs.) (kg)
			L	D	H*						
TA1HRI-1S	1	37 1048	35 889	34 1/2 877	83 3/4 2128	2000	115/208-240/1	8.3	14-20P ▲	9 2.74	325 148

\* Height does not include 1" (26 mm) for system mechanical components.  
Requires 115/208 -240/60 Hz, single phase, 3 pole, 4 wire circuit.

▲ Plug type varies by country.



#### APPROVALS:

Model:  
**TA1HRI-1S**

**TA Specification Series:**  
*Roll-In Solid Door Heated Cabinet*



**STANDARD FEATURES**

**DESIGN**

- True's solid door roll-in heated cabinets are designed with enduring quality that protects your long term investment.

**HEATER SYSTEM**

- Cabinet is designed to provide holding temperatures of 80°F to 180°F (26.67°C to 82.22°C). Heating system controlled by exterior on/off switch and temperature control dial.
- (2) stainless steel, finned tube heating elements (1000 watts each) per section for uniform generation of electric heat. Cabinet comes with a total of 2000 watts.
- Cabinet equipped with low-velocity fan to assure even temperature distribution throughout the cabinet. Fans are controllable by exterior on/off switch.
- Manually controlled vent located on top of the cabinet for positive humidity control.
- Exterior dial thermometer; accurate direct reading of internal cabinet temperature.

**CABINET CONSTRUCTION**

- Exterior - 300 series stainless steel door, front, back and bottom. Stainless steel sides.
- Interior- anodized aluminum liner. 300 series stainless steel floor with coved corners.
- Stainless steel breaker cap.
- Insulation - entire cabinet structure and solid door is foamed-in-place using

high density, CFC free, polyurethane insulation.

- (1) heavy gauge stainless steel ramp standard per door.
- Designed to accept roll-in racks (inboard castors) with a maximum dimensions of 27"L x 29"D x 66"H (686 mm x 737 mm x 1677 mm).

**DOORS**

- 300 series stainless steel door liner. Door opens within cabinet dimension. Door lock standard.
- (3) lifetime guaranteed, cam-lift hinges per door. Full 180 degree open capability with a stay open feature at 120 degrees.
- Lifetime guaranteed recessed door handle. Each door fitted with 12" (305 mm) long recessed handle that is foamed-in-place with a sheet metal interlock to insure permanent attachment.
- Magnetic door gasket of one piece construction, removable without tools for ease of cleaning.
- Door is field reversible.

**LIGHTING**

- Incandescent interior lighting; safety shielded.

**MODEL FEATURES**

- True heated cabinets are designed to hold warm baked or cooked food. Cabinets are not designed to heat ambient or cold product.

**ELECTRICAL**

- Unit completely pre-wired at factory and ready for final connection to a 115/208-240/60 Hz. Single phase - 20 amp dedicated outlet.
- Cord and plug set included.



115/208-240/1  
NEMA-14-20R

**OPTIONAL FEATURES/ACCESSORIES**

- Metal door handle.
- Export units - consult factory.
- Prison package options - consult factory.
- Remote cabinets (condensing units supplied by others), consult factory technical service department for BTU information.

**PLAN VIEW**

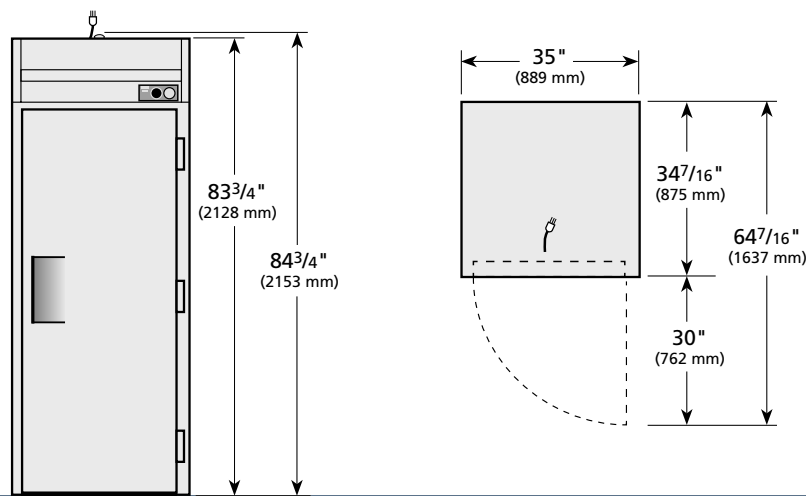

FRONT VIEW

TOP VIEW

**WARRANTY**

One year warranty on all parts & labor (U.S.A. only)

METRIC DIMENSIONS ROUNDED UP TO THE NEAREST WHOLE MILLIMETER

SPECIFICATIONS SUBJECT TO CHANGE WITHOUT NOTICE



Model	Front	Side	Plan	3D
TA1HRI-1S	TFQY82E	TFQY51S	TFQY51P	TFQY823

**TRUE FOOD SERVICE EQUIPMENT**