



TRUE FOOD SERVICE EQUIPMENT, INC.

2001 East Terra Lane • P.O. Box 970 • O'Fallon, Missouri 63366
 (636)240-2400 • Fax (636)272-2408 • (800)325-6152 • Intl Fax# (001)636-272-7546
 Parts Dept. (800)424-TRUE • Parts Dept. Fax# (636)272-9471 • www.truemfg.com

Project Name: _____

Location: _____

Item #: _____ Qty: _____

Model #: _____

A/A #

SIS #

Model:
TA1H-2HS

TA Specification Series:
Reach-In Solid Half Door Heated Cabinet



TA1H-2HS

- ▶ Provides cabinet holding temperature of 80°F to 180°F (26.6°C to 82.2°C).
- ▶ Equipped with low-velocity fans to assure even temperature distribution throughout the cabinet. Fans are controlled by exterior on/off switch.
- ▶ Two (2) stainless steel (for corrosion resistance), finned tube heating elements (1000 watts each) for uniform generation of electric heat. Cabinet comes with a total of 2000 watts.
- ▶ 300 series stainless steel exterior front, sides, back and bottom. The very finest stainless with higher tensile strength for fewer dents and scratches.
- ▶ Anodized aluminum interior cabinet liner. 300 series stainless steel door liners and floor with coved corners.
- ▶ Three (3) adjustable, heavy duty chrome plated wire shelves.
- ▶ Positive seal self-closing doors with 120° stay open feature. Lifetime guaranteed door hinges and recessed door handles.
- ▶ Entire cabinet structure and solid doors are foamed-in-place using high density, CFC free, polyurethane insulation.

ROUGH-IN DATA

Specifications subject to change without notice.
 Chart dimensions rounded up to the nearest 1/8" (millimeters rounded up to next whole number).

Model	Doors	Capacity (Cu. Ft.) (liters)	Cabinet Dimensions (inches) (mm)			Watts	Voltage	NEMA Config.	Cord Length (total ft.) (total m)	Crated Weight (lbs.) (kg)
			L	D†	H*					
TA1H-2HS	2	31 878	29 737	34 ⁵ / ₈ 880	78 ¹ / ₄ 1988	2000	115/208-240/60/1	14-20P	9 2.74	n/a n/a

† Depth does not include 1 1/8" (29 mm) system mechanical components.

* Height does not include 6 1/8" (156 mm) for legs, 5" (127 mm) for optional castors and 1" (26 mm) for system mechanical components.

Requires 115/208 -240/60 Hz, single phase, 3 pole, 4 wire circuit.



5/07

Printed in U.S.A.

APPROVALS:

AVAILABLE AT:

Model:
TA1H-2HS

TA Specification Series:
Reach-In Solid Half Door Heated Cabinet



STANDARD FEATURES

DESIGN

- True's solid door reach-in heated cabinets are designed with enduring quality that protects your long term investment.

HEATER SYSTEM

- Cabinet designed to provide holding temperatures of 80°F to 180°F (26.6°C to 82.2°C). Heating system controlled by exterior on/off switch and temperature control dial.
- Two (2) stainless steel (for corrosion resistance), finned tube heating elements (1000 watts each) for uniform generation of electric heat. Cabinet comes with a total of 2000 watts.
- Equipped with low-velocity fans to assure even temperature distribution throughout the cabinet. Fans are controlled by exterior on/off switch.
- Manually controlled vent located on top of the cabinet for positive humidity control.
- 12" x 20" (305 mm x 508 mm) pan for water included, if additional humidity required.

CABINET CONSTRUCTION

- Exterior - 300 series stainless steel doors, front, sides, back and bottom.
- Interior - NSF approved anodized aluminum side walls and back liner. 300 series stainless floor with coved corners.
- Insulation - entire cabinet structure and solid doors are foamed-in-place using high density, CFC free, polyurethane insulation.
- Welded, heavy duty galvanized frame rail dipped in rust inhibiting enamel paint for corrosion protection inside and out.
- Frame rail fitted with 6" (153 mm) stainless steel legs.

DOORS

- 300 series stainless steel exterior and liners. Doors open within cabinet dimension.
- Door locks standard.
- Lifetime guaranteed recessed door handles. Each door fitted with 12" (305 mm) long recessed handle that is foamed-in-place with a sheet metal interlock to ensure permanent attachment.

- Positive seal self-closing doors with 120° stay open feature. Lifetime guaranteed door hinges.
- Magnetic door gaskets of one piece construction, removable without tools for ease of cleaning.

SHELVING

- Three (3) chrome shelves 25" x 27³/₄" (635 mm x 705 mm) with shelf clips and wall mounted pilasters (field installed). 1¹/₁₆" (27 mm) standoff ensures optimum airflow.
- Aluminum shelf support pilasters. Shelves are adjustable on 1/2" (13 mm) increments.
- Three (3) different interior kits available (see Kit Options). Pilasters and tray slides require field installation.

LIGHTING

- Incandescent interior lighting - lights activated by exterior on/off switch, safety shielded.

MODEL FEATURES

- Exterior, color coded, dial thermometer; accurate direct reading of internal cabinet temperature.
- Designed to hold warm baked or cooked food. Cabinet is not designed to heat ambient or cold product.
- NSF-4 compliant for open food product.

ELECTRICAL

- True requires that a sole use circuit be dedicated for the unit.
- Unit completely pre-wired at factory and ready for final connection to a 115/208-240/60 Hz. single phase, 20 amp dedicated outlet. Cord and plug set included.



115/208-240/1
NEMA-14-20R

OPTIONAL FEATURES/ACCESSORIES

Upcharge and lead times may apply.

- Seismic/flanged legs.
- 4" (102 mm) diameter stem castors.
- Stainless steel rail skirt for use with legs (field installed).
- Additional shelves.
- Stainless steel (electro polished) shelves.
- Metal door handles (factory installed).
- Electronic temperature control (factory installed).
- Curb mountable units.

KIT OPTIONS

Upcharge applies. Lead times may apply.

- Kit #1: Nine (9) sets of #1 type tray slides and pilasters (field installed), bottom support of one (1) 18"L x 26"D (458 mm x 661 mm) pan or two (2) 14"L x 18"D (356 mm x 458 mm) pans.
- Kit #2: One (1) set half-section #2 steel rod tray slides and pilasters (field installed), rim support of one (1) 18"L x 26"D (458 mm x 661 mm) pan.
- Kit #3: Six (6) sets of universal type tray slides and pilasters (field installed), bottom support of one (1) 18"L x 26"D (458 mm x 661 mm) pan, two (2) 14"L x 18"D (356 mm x 458 mm) pans or two (2) 12"L x 20"D (305 mm x 508 mm) pans.
- Additional kit option components available individually.

PLAN VIEW

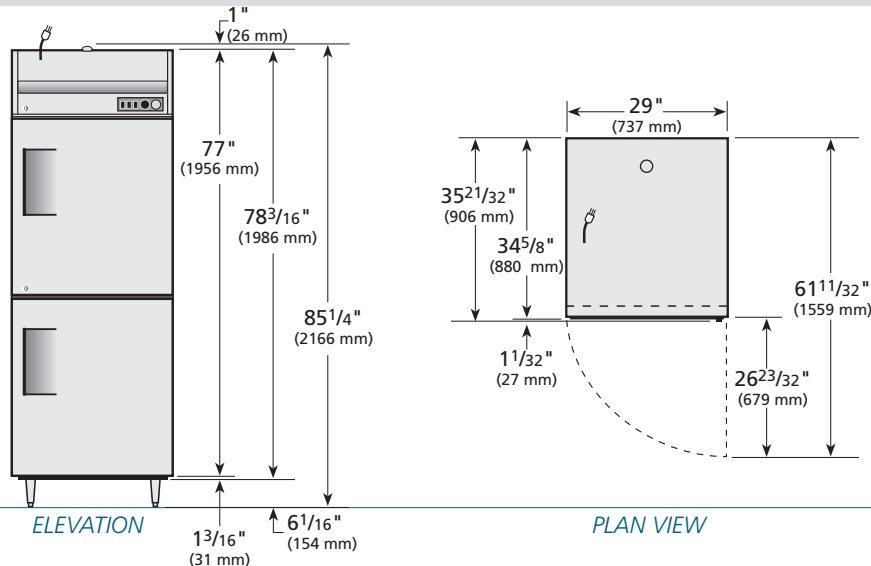

WARRANTY
One year warranty on all parts and labor (U.S.A. only)

METRIC DIMENSIONS ROUNDED UP TO THE NEAREST WHOLE MILLIMETER
SPECIFICATIONS SUBJECT TO CHANGE WITHOUT NOTICE

	Model	Elevation	Right	Plan	3D
	TA1H-2HS	TFQX179E	TFQX179S	TFQX60P	TFQX1793

TRUE FOOD SERVICE EQUIPMENT