



# TRUE FOOD SERVICE EQUIPMENT, INC.

St. Charles Industrial Center • P.O. Box 970 • O'Fallon, Missouri 63366  
(636)240-2400 • FAX (636)272-2408 • (800)325-6152 • www.truemfg.com  
Parts Dept. (800)424-TRUE • Parts Dept. FAX# (636)272-9471

Project Name: \_\_\_\_\_

Location: \_\_\_\_\_

Item #: \_\_\_\_\_ Qty: \_\_\_\_\_

Model #: \_\_\_\_\_

A/A #

SIS #

Model:  
**TA1H-1S**

## TA Specification Series: *Reach-In Solid Door Heated Cabinet*



### TA1H-1S

- ▶ Provides cabinet holding temperature of 80°F to 180°F (26.67°C to 82.22°C).
- ▶ Internal fan provides low velocity, forced-air heat distribution to assure even temperatures throughout the cabinet.
- ▶ (2) stainless steel 1000 watt finned tube heating elements per section for uniform generation of electric heat. Cabinet comes with a total of 2000 watts.
- ▶ 300 series stainless steel exterior front, back, and bottom. The very finest stainless; higher tensile strength for fewer dents and scratches.
- ▶ Anodized aluminum interior cabinet liner. 300 series stainless steel door liner and floor with coved corners.
- ▶ Three (3) adjustable, heavy duty chrome plated wire shelves 25" L x 27 3/4" D (635 mm x 705 mm) with 1" (26 mm) standoff. Four (4) chrome plated shelf clips to be included per shelf.
- ▶ Entire cabinet structure and solid doors are foamed-in-place using high density, CFC free, polyurethane insulation.
- ▶ Positive seal self-closing doors with 120 degrees stay open feature. Lifetime guaranteed door hinges and recessed door handles.

### ROUGH-IN DATA

Specifications subject to change without notice.  
Chart dimensions rounded up to the nearest 1/8" (millimeters rounded up to next whole number).

Model	Solid Doors	Capacity (Cu. Ft.) (liters)	Cabinet Dimensions (inches) (mm)			Watts	Voltage	Amps	NEMA Config.	Cord Length (total ft.) (total m)	Crated Weight (lbs.) (kg)
			L	D	H*						
TA1H-1S	1	31 878	29 737	34 5/8 880	78 1/4 1988	2000	115/208-240/1	8.3	14-20P ▲	9 2.74	350 159

\* Height does not include 6" (153 mm) for legs and 1" (26 mm) for system mechanical components.  
Requires 115/208 -240/60 Hz, single phase, 3 pole, 4 wire circuit.

▲ Plug type varies by country.



#### APPROVALS:

Model:  
**TA1H-1S**

## TA Specification Series: Reach-In Solid Door Heated Cabinet



### STANDARD FEATURES

#### DESIGN

- True's solid door reach-in heated cabinets are designed with enduring quality that protects your long term investment.

#### HEATER SYSTEM

- Cabinet is designed to provide holding temperatures of 80°F to 180°F (27°C to 83°C). Heating system controlled by exterior on/off switch and temperature control dial.
- Two stainless steel, finned tube heating elements (1000 watts each) per section for uniform generation of electric heat. Cabinet comes with a total of 2000 watts.
- Cabinet equipped with low-velocity fan to assure even temperature distribution throughout the cabinet. Fans are controllable by exterior on/off switch.
- Manually controlled vent located on top of the cabinet for positive humidity control.
- Exterior dial thermometer; accurate direct reading of internal cabinet temperature.

#### CABINET CONSTRUCTION

- Exterior - 300 series stainless steel door, front, sides, back and bottom.
- Interior- anodized aluminum liner. 300 series stainless floor with coved corners.
- Stainless steel breaker cap.
- Insulation - entire cabinet structure and solid door are foamed-in-place using high density, CFC free, polyurethane insulation.
- Cabinet mounted on a welded, heavy duty galvanized frame rail. Rail dipped in rust inhibiting enamel paint for corrosion protection inside and out.
- Frame rail fitted with 6" (153 mm) adjustable legs.

#### DOORS

- 300 series stainless steel exterior and door liner. Door opens within cabinet dimension.

- Door lock standard.
- Lifetime guaranteed recessed door handle. Door fitted with 12" (305 mm) long recessed handle that is foamed-in-place with a sheet metal interlock to insure permanent attachment.
- Magnetic door gasket of one piece construction, removable without tools for ease of cleaning.

#### SHELVING

- Three (3) adjustable, heavy duty chrome plated wire shelves 25"L x 27 3/4"D (635 mm x 705 mm) with 1" (26 mm) standoff. Four (4) chrome plated shelf clips to be included per shelf.
- Additional tray slide options available.
- Shelf support pilasters made of same material as cabinet interior; shelves are adjustable on 1/2" (13 mm) increments.

#### LIGHTING

- Incandescent interior lighting; safety shielded.

#### MODEL FEATURES

- True heated cabinets are designed to hold warm baked or cooked food. Cabinets are not designed to heat ambient or cold product.

#### ELECTRICAL

- Unit completely pre-wired at factory and ready for final connection to a 115/208-240/60 Hz. Single phase - 20 amp dedicated outlet.
- Cord and plug set included.



115/208-240/1  
NEMA-14-20R

#### OPTIONAL FEATURES/ACCESSORIES

- 4" (102 mm) diameter swivel castors.
- Seismic/flanged legs.
- Stainless steel (electro polished) shelves.
- All stainless steel legs.
- Chrome shelves.
- Universal pan slides.
- #1 pan slides.
- #2 rod style pan slides.
- Curb mountable units.
- Export units - consult factory.
- Prison package options - consult factory.
- Metal door handle.
- Remote cabinets (condensing units supplied by others), consult factory technical service department for BTU information.

#### KIT OPTIONS

- Kit #1: Nine sets of #1 type tray slides, bottom support of one 18" x 26" (456 mm x 661 mm) pan or two 14" x 18" (356 mm x 456 mm) pans.
- Kit #2: One set half-section #2 steel rod tray slides, rim support of one 18" x 26" (456 mm x 661 mm) pan.
- Kit #3: Six sets of universal type tray slides, bottom support of one 18" x 26" (456 mm x 661 mm) pan, two 14" x 18" (356 mm x 456 mm) pans or two 12" x 20" (305 mm x 508 mm) pans.
- Kit #4: Three chrome shelves 25" x 27 3/4" with 1" (26 mm) standoff (635 mm x 705 mm) and chrome plated shelf supports.

### PLAN VIEW

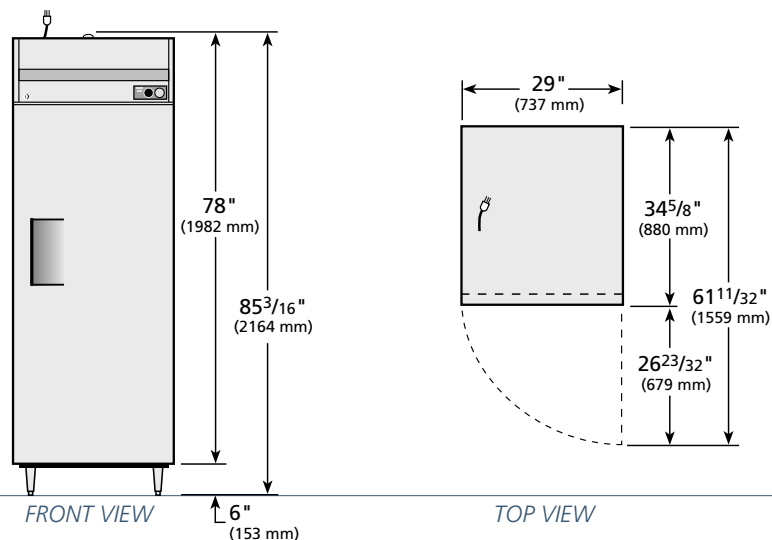

#### WARRANTY

One year warranty on all parts & labor (U.S.A. only)

METRIC DIMENSIONS ROUNDED UP TO THE NEAREST WHOLE MILLIMETER

SPECIFICATIONS SUBJECT TO CHANGE WITHOUT NOTICE



Model	Front	Side	Plan	3D
TA1H-1S	TFQY79E	TFQX72S	TFQX60P	TFQY793

### TRUE FOOD SERVICE EQUIPMENT