



# TRUE FOOD SERVICE EQUIPMENT, INC.

2001 East Terra Lane • P.O. Box 970 • O'Fallon, Missouri 63366  
(636)240-2400 • Fax (636)272-2408 • (800)325-6152 • Intl Fax# (001)636-272-7546  
Parts Dept. (800)424-TRUE • Parts Dept. Fax# (636)272-9471 • www.truemfg.com

Project Name: \_\_\_\_\_

A/A #

Location: \_\_\_\_\_

Item #: \_\_\_\_\_ Qty: \_\_\_\_\_

SIS #

Model #: \_\_\_\_\_

Model:  
**T-24-GC-S**

## Glass and Plate Chiller/Froster: *Solid Lid, Stainless Steel Exterior*



### T-24-GC-S

- ▶ True's glass and plate chiller/frosters are designed with enduring quality and value. Our commitment to using the highest quality materials and oversized refrigeration assures colder product temperatures and years of trouble free service.
- ▶ Large storage capacity to meet the supply and demand requirements during peak hours.
- ▶ Oversized, factory balanced, refrigeration system holds 0°F (-17.7°C) and below.
- ▶ Forced-air cooling, positively guided airflow provide efficient balanced temperatures throughout the cabinet. This unique design ensures fast frosting of dry glasses and plates.
- ▶ Exterior - all stainless steel countertop, lid, front and sides. Matching aluminum back.
- ▶ Interior - long lasting, heavy duty galvanized steel.
- ▶ Evaporator - epoxy coated at the time of manufacture to eliminate the potential of corrosion.
- ▶ Entire cabinet structure and lid are foamed-in-place using high density, CFC free, polyurethane insulation.
- ▶ Heavy duty, 10 mil thick pure grade PVC coated adjustable shelves.

### ROUGH-IN DATA

Specifications subject to change without notice.

Chart dimensions rounded up to the nearest 1/8" (millimeters rounded up to next whole number).

Model	Lids	Capacity		Shelves	Cabinet Dimensions (inches)			HP	Voltage	Amps	NEMA Config.	Cord Length (total ft.)	Crated Weight (lbs.)
		8" (204 mm) Mugs	10 oz. Steins		L	D†	H						
T-24-GC-S	1	90	85	2	24 <sup>3</sup> / <sub>4</sub> 629	26 <sup>5</sup> / <sub>8</sub> 677	33 <sup>3</sup> / <sub>8</sub> 848	1/4 1/3	115/60/1 230-240/50/1	5.8 2.7	5-15P ▲	9 2.74	180 82

† Depth does not include 1" (26 mm) for rear bumpers.

▲ Plug type varies by country.



APPROVALS:

AVAILABLE AT:

Model:  
**T-24-GC-S**

**Glass & Plate Chiller/Froster:**  
*Solid Lid, Stainless Steel Exterior*



**STANDARD FEATURES**

**DESIGN**

- True's glass and plate chiller/frosters are designed with enduring quality and value. Our commitment to using the highest quality materials and oversized refrigeration assures colder product temperatures and years of trouble free service.

**REFRIGERATION SYSTEM**

- Factory engineered, self-contained, capillary tube system using environmentally friendly (CFC free) 404A refrigerant.
- Extra large evaporator coil balanced with higher horsepower compressor and large condenser; maintains cabinet temperatures of 0°F (-17.7°C) and below.
- Sealed, cast iron, self-lubricating evaporator fan motor(s) and larger fan blades give True chiller/frosters a more efficient low velocity, high volume airflow design. This unique design ensures fast frosting of dry glasses and plates.
- Automatic defrost system time-initiated, time-terminated.
- Condensing unit accessed from behind front grill, slides out for easy maintenance.
- Forced-air cooling, positively guided airflow provide efficient balanced temperatures throughout the cabinet.

**CABINET CONSTRUCTION**

- Exterior - all stainless steel countertop, lid, cabinet front and sides, matching aluminum back.
- Interior - long lasting, heavy duty galvanized steel.
- Insulation - entire cabinet structure is foamed-in-place using high density, CFC free, polyurethane insulation.
- Welded, heavy duty galvanized base rail dipped in rust inhibiting enamel paint for corrosion protection inside and out.

**SHELVING**

- Two (2) adjustable, heavy duty PVC coated wire shelves 10<sup>1</sup>/<sub>4</sub>" L x 19<sup>5</sup>/<sub>16</sub>" D (261 mm x 491 mm). Split shelf design allows for effective rotation of chilled smallware, working with already chilled plates and glasses on one side while chilling dry product on other side.

**MODEL FEATURES**

- Evaporator is epoxy coated to eliminate the potential of corrosion.
- Listed under NSF-7 for the storage and/or display of packaged or bottled product.

**ELECTRICAL**

- Unit completely pre-wired at factory and ready for final connection to a 115/60/1 phase - 15 amp dedicated outlet. Cord and plug set included.



115/60/1  
NEMA-5-15R

**OPTIONAL FEATURES/ACCESSORIES**

- Upcharge and lead times may apply.
- 230-240V / 50 Hz.
  - 6" (153 mm) standard legs.
  - 6" (153 mm) seismic/flanged legs.
  - 2<sup>1</sup>/<sub>2</sub>" (64 mm) diameter castors.
  - 3" (77 mm) diameter castors.
  - Ratchet lock and handle.
  - Floor racks.
  - Additional shelves.
  - Remote cabinets (condensing unit supplied by others; system comes standard with 404A expansion valve and requires R404A refrigerant). Consult factory technical service department for BTU information.

**PLAN VIEW**

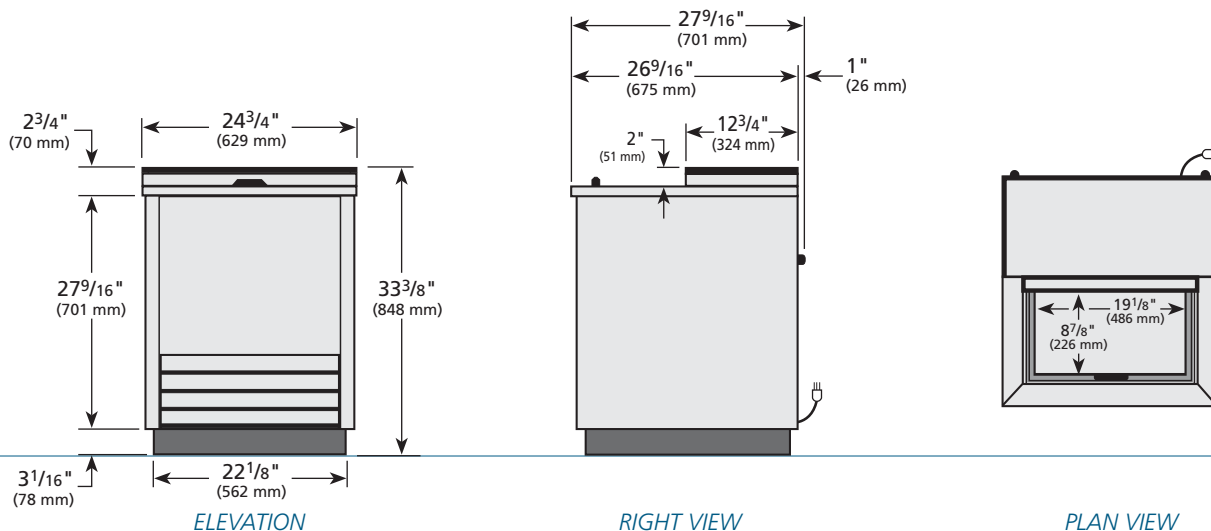

**WARRANTY**  
 One year warranty on all parts and labor and an additional 4 year warranty on compressor. (U.S.A. only)

METRIC DIMENSIONS ROUNDED UP TO THE NEAREST WHOLE MILLIMETER  
 SPECIFICATIONS SUBJECT TO CHANGE WITHOUT NOTICE



Model	Elevation	Right	Plan	3D
T-24-GC-S	TFLY03E	TFLY01S	TFLY03P	TFLY033

**TRUE FOOD SERVICE EQUIPMENT**