



TRUE FOOD SERVICE EQUIPMENT, INC.

2001 East Terra Lane • P.O. Box 970 • O'Fallon, Missouri 63366
(636)240-2400 • Fax (636)272-2408 • (800)325-6152 • Intl Fax# (001)636-272-7546
Parts Dept. (800)424-TRUE • Parts Dept. Fax# (636)272-9471 • www.truemfg.com

Project Name: _____

Location: _____

Item #: _____ Qty: _____

Model #: _____

A/A #

SIS #

Model:
T-23DT

DT Series:

Reach-In Solid Door, Dual Temperature Refrigerator/Freezer



T-23DT

- ▶ Designed using the highest quality materials and components to provide the user with colder product temperatures, lower utility costs, exceptional food safety and the best value in today's food service marketplace.
 - ▶ Refrigerator located in top section; freezer on bottom.
 - ▶ Equipped with two, self-contained, independent refrigeration systems. Oversized and factory balanced; refrigerator section holds 33°F to 38°F (.5°C to 3.3°C); freezer holds -10°F (-23.3°C).
 - ▶ 300 series stainless steel solid doors and front. The very finest stainless with higher tensile strength for fewer dents and scratches.
 - ▶ Adjustable, heavy duty PVC coated shelves.
 - ▶ Positive seal self-closing doors. Lifetime guaranteed door hinges and torsion type closure system.
- Bottom mounted units feature:**
- ▶ "No stoop" lower shelf.
 - ▶ Storage on top of cabinet.
 - ▶ Compressor performs in coolest, most grease free area of kitchen.
 - ▶ Easily accessible condenser coil for cleaning.

ROUGH-IN DATA

Specifications subject to change without notice.
Chart dimensions rounded up to the nearest 1/8" (millimeters rounded up to next whole number).

Model	Doors	Capacity (Cu. Ft.) (liters)		Shelves	Cabinet Dimensions (inches) (mm)			HP		Voltage	Total Amps	NEMA Config.	Cord Length (total ft.) (total m)	Crated Weight (lbs.) (kg)
		Ref.	Frz.		L	D	H*	Ref.	Frz.					
T-23DT	2	11 312	8 227	3	27 686	29 1/2 750	78 3/8 1991	1/5 1/5	1/3 1/3	115/60/1 230-240/50/1	12.0 6.5	5-15P ▲	9 2.74	320 146

* Height does not include 5" (127 mm) for castors or 6" (153 mm) for optional legs.

▲ Plug type varies by country.



8/07

Printed in U.S.A.

APPROVALS:

AVAILABLE AT:

Model:
T-23DT

DT Series:
Reach-In Solid Door, Dual Temperature
Refrigerator/Freezer



STANDARD FEATURES

DESIGN

- True's solid door reach-in's are designed with enduring quality that protects your long term investment.
- True's commitment to using the highest quality materials and oversized refrigeration systems provides the user with colder product temperatures, lower utility costs, exceptional food safety and the best value in today's food service marketplace.

REFRIGERATION SYSTEM

- Equipped with two, independent, factory engineered, self-contained, capillary tube refrigeration systems using environmentally friendly (CFC free) refrigerant. Refrigerator uses 134A and freezer uses R404A.
- Refrigerator located in top section; freezer on bottom.
- Extra large evaporator coils balanced with higher horsepower compressors and large condensers; maintain colder standard temperatures for the best in food preservation. Refrigerator holds 33°F to 38°F (.5°C to 3.3°C); freezers holds -10°F (-23.3°C).
- Sealed, cast iron, self-lubricating evaporator fan motors and larger fan blades give True reach-in's a more efficient low velocity, high volume airflow design. This unique design ensures faster temperature recovery and shorter run times in the busiest of foodservice environments.
- Bottom mounted condensing unit positioned for easy cleaning. Compressor runs in coolest and most grease free area of the kitchen. Allows for storage area on top of unit.
- Automatic freezer defrost system is time-initiated, time-terminated.

CABINET CONSTRUCTION

- Exterior - 300 series stainless steel front. Anodized quality aluminum exterior ends, back and top.

- Interior - attractive, NSF approved, white aluminum liner. 300 series stainless floor with coved corners.
- Insulation - entire cabinet structure and solid doors are foamed-in-place using high density, CFC free, polyurethane insulation.
- Welded, heavy duty galvanized frame rail dipped in rust inhibiting enamel paint for corrosion protection inside and out.
- Frame rail fitted with 4" (102 mm) diameter stem castors - locks provided on front set.

DOORS

- 300 series stainless steel exterior with white aluminum liners to match cabinet interior. Doors extend full width of cabinet shell. Door locks standard.
- Lifetime guaranteed recessed door handles. Each door fitted with 12" (305 mm) long recessed handle that is foamed-in-place with a sheet metal interlock to ensure permanent attachment.
- Positive seal self-closing doors. Lifetime guaranteed door hinges and torsion type closure system.
- Magnetic door gaskets of one piece construction, removable without tools for ease of cleaning.

SHELVING

- Three (3) adjustable, heavy duty PVC coated wire shelves 22⁷/₈" L x 23¹/₄" D (582 mm x 591 mm). Four (4) chrome plated shelf clips included per shelf.
- Shelf support pilasters made of same material as cabinet interior; shelves are adjustable on 1/2" (13 mm) increments.

LIGHTING

- Compartmentalized, incandescent interior lighting (one per section) - safety shielded. Lights activated by rocker switch mounted above top door.

MODEL FEATURES

- Two (2) exterior mounted digital temperature displays. One for refrigerator section and one for freezer section.
- Evaporator is epoxy coated to eliminate the potential of corrosion.
- Minimum wattage heater in cabinet frame and freezer door.
- NSF-7 compliant for open food products.

ELECTRICAL

- Unit completely pre-wired at factory and ready for final connection to a 115/60/1 phase, 15 amp dedicated outlet. Cord and plug set included.



115/60/1
NEMA-5-15R

OPTIONAL FEATURES/ACCESSORIES

Upcharge and lead times may apply.

- 230-240V/50Hz.
- 6" (153 mm) standard legs.
- 6" (153 mm) seismic/flanged legs.
- Additional shelves.
- Novelty baskets.
- Half door bun tray rack (refrigerator section only). Each holds up to eleven 18" L x 26" D (458 mm x 661 mm) sheet pans (sold separately).
- Remote cabinets (condensing unit supplied by others; system comes standard with 404A expansion valve and requires R404A refrigerant). Consult factory technical service department for BTU information.

PLAN VIEW

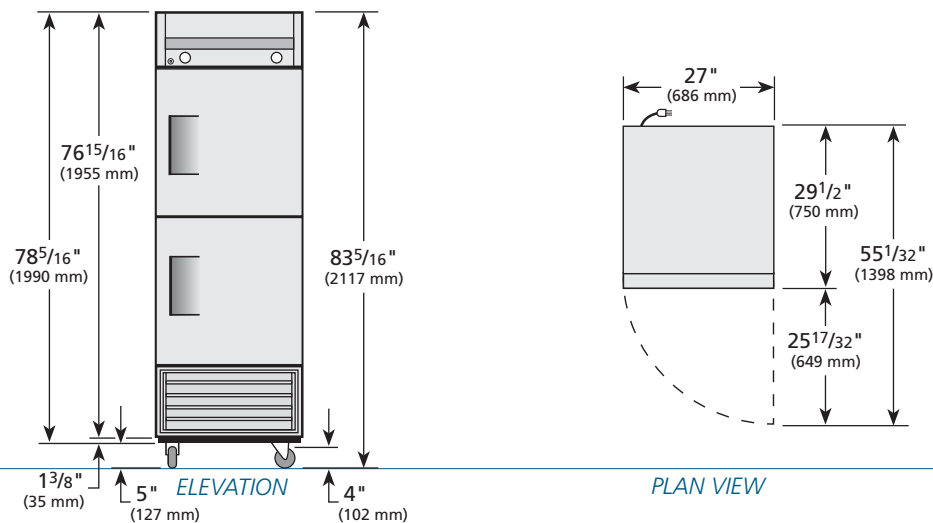

WARRANTY
One year warranty on all parts & labor and an additional 4 year warranty on compressor. (U.S.A. only)

METRIC DIMENSIONS ROUNDED UP TO THE NEAREST WHOLE MILLIMETER
SPECIFICATIONS SUBJECT TO CHANGE WITHOUT NOTICE



Model	Elevation	Right	Plan	3D
T-23DT	TFEY55E	TFGY07S	TFEY03P	TFEY553

TRUE FOOD SERVICE EQUIPMENT