



TRUE FOOD SERVICE EQUIPMENT, INC.

St. Charles Industrial Center • P.O. Box 970 • O'Fallon, Missouri 63366
(636)240-2400 • FAX (636)272-2408 • (800)325-6152 • www.truemfg.com

Project Name: _____

AIA #

Location: _____

S/S #

Item #: _____ Qty: _____

Model #: _____

T-Series Reach-In Freezers



T-23F

TRUE, rated the #1 brand in America.

Solid Door Reach-In Freezers

- T-12F**, **T-19F**, **T-19FZ**, **T-23F**
- (single door models)**

SPECIFICATIONS / FEATURES

DOORS:

- 300 series stainless steel exterior with white aluminum interior to match cabinet liner. Doors extend full width of cabinet shell. Door gaskets of one piece construction.
- Lifetime guaranteed adjustable torsion type closure system with aluminum block supports. The face of each door fitted with a 12" long recessed handle with sheetmetal interlock. Handles are foamed-in-place to insure permanent attachment.

INSULATION:

- Entire cabinet structure and doors insulated using foamed-in-place CFC free polyurethane foam.

SHELVING:

- Adjustable vinyl coated wire shelves (3 per section). Shelves capable of supporting up to 250 lbs.
- Full height shelf support pilasters, with double oblong holes on 1/2" centers. Pilasters made of the same material as cabinet interior. Four (4) chrome plated, stainless steel shelf clips to be included for each shelf.

LIGHTING:

- Incandescent interior lighting. Light(s) activated by rocker switch mounted above door(s).

REFRIGERATION SYSTEM:

- Refrigeration system factory balanced using CFC free R404A refrigerant.
- Bottom mounted condensing unit - easy access for maintenance.
- Factory pre-engineered capillary tube system with oversized condenser (excluding T-19FZ) and evaporator to reduce product pull down time and to consistently maintain -10°F (T-19FZ holds 0°F) interior cabinet temperature. (non-adjustable capillary tube system superior to problematic expansion valve)
- Defrost system time initiated, temperature terminated.
- Automatic evaporator fan motor delay during defrost cycle.
- Large evaporator and coil heater permit short defrost cycle.
- Evaporator - epoxy coated at the time of manufacture to eliminate the potential of corrosion.

ELECTRICAL CHARACTERISTICS:

- Unit completely pre-wired at factory, and ready for final connection to appropriate outlet (see diagram below and NEMA listing next page. A cord and plug set to be included.
- A sole use circuit is required.



115/60/1
NEMA-5-15R

SPECIFICATIONS / FEATURES

CABINET CONSTRUCTION:

- 300 series stainless steel front grill, shroud and doors. Anodized quality aluminum exterior ends and back.
- NSF approved, white vinyl coated aluminum and 300 series stainless floor with coved corners.
- Barrel lock standard for each door (excluding T-12F). Dial exterior mounted temperature monitor.
- Cabinet mounted on a welded, galvanized frame rail, painted for additional corrosion protection. Frame rail fitted with 4" diameter castors, front castors include brakes (castors not available for the T-12F; 2 1/2" castors standard for T-19F & -FZ).
- Rear wall airflow guard prevents frozen product from blocking optimal airflow.

Also available:

- **Two and Three Door Models**
- **Refrigerators**
- **All Stainless Steel In / Out**
- **Dual Temperature Models**
- **Top Mounts**
- **Glass Door Models**
- **Half Door Models**

Remote cabinets and condensing units available for models T-23F, T-49F, and T-72F. For other models remote cabinets available 14% off list (condensing units supplied by others). Consult factory technical service dept. for BTU information.

Specifications subject to change without notice.

Printed in U.S.A.



APPROVALS:



T-Series: Single Solid Door Reach-In Freezers

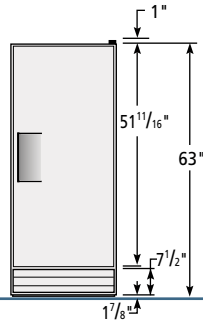
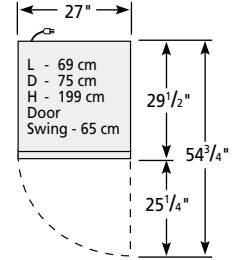
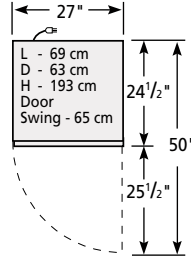
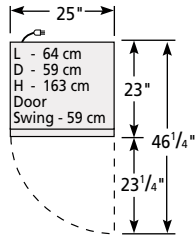

T-12F

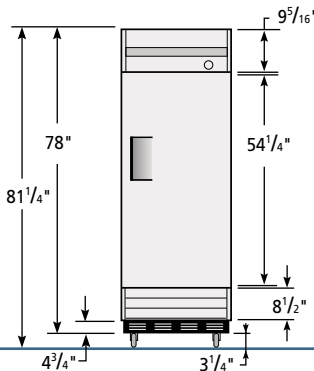

T-19F & T-19FZ

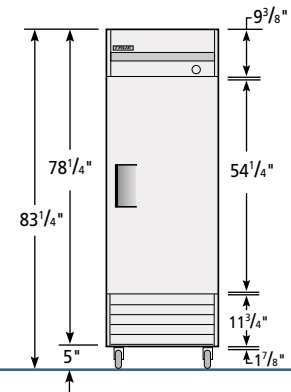

T-23F

Rough-In Data

Model	Doors	Capacity (Cu. Ft)	# of Shelves	Dimensions (inches)			HP	Volts	PH	Amps	NEMA Config.	Cord Length (feet)	Crated Weight
				L	D	H*							
T-12F (1)	1	12	3	25	23	64	1/3	115	1	6.2	5-15	6	195
T-19F (1)	1	19	3	27	24 1/2	78	1/2	115	1	7.3	5-15	9	268
T-19FZ 0°	1	19	3	27	24 1/2	78	1/3	115	1	8.4	5-15	9	268
T-23F (1, 2)	1	23	3	27	29 1/2	78 1/4	1/2	115	1	10.1	5-15	9	290

Specifications subject to change without notice.

(1) Available with full glass doors

(2) Available with solid half doors

* Height does not include 5" for castor height or 6" for optional legs on T-23F;

3 1/4" for castors on T-19F & T-19FZ, legs available;

T-12F standard with leg levelers, available with optional 2 1/2" diameter castors, legs not available.

Standard Features

- Oversized and balanced, environmentally friendly (R404A) refrigeration system holds -10°F (T-19FZ holds 0°F).
- 300 series stainless steel doors & front.
- Interior - NSF approved, white vinyl coated aluminum sides and top, 300 series stainless steel floor with coved corners.
- Anodized quality aluminum top, sides and back.
- Airflow backguard provided for improved airflow.
- Recessed handles (lifetime guaranteed).
- Exterior mounted temperature monitor. (not available for T-12F).
- Door locks (not available for T-12F).
- Large evaporator and coil heater permit short defrost cycle.
- Magnetic door gaskets.
- Adjustable vinyl coated wire shelves.
- Epoxy coated evaporator.
- Incandescent interior lighting (fluorescent interior lighting for glass door models).
- Foamed-in-place high density polyurethane insulation (CFC free).
- T-23F: 4" diameter swivel castors standard equipment - locking castors provided for front set.
- T-19F & T-19FZ: 2 1/2" diameter castors standard equipment.
- T-12F: leg levelers standard.
- Slide out compressor can be serviced easily and accessed by a single repairman.
- Defrost system time initiated, temperature terminated.
- Automatic evaporator fan motor delay during defrost cycle.
- 1 year parts & labor warranty (USA).
- 5 year compressor warranty.

Optional Accessories

- T-23F available with 6" stainless steel or optional seismic legs
- Additional shelves available.
- Optional novelty baskets available.

Clearance Required For Coolers (USA)		
Sides Inches/mm	Top* Inches/mm	Rear Inches/mm
0 / 0	1 / 26	3 / 77

* T-12F, T-19F & -FZ only.



TRUE FOOD SERVICE EQUIPMENT