



**TRUE FOOD SERVICE EQUIPMENT, INC.**

2001 East Terra Lane • O'Fallon, Missouri 63366  
 (636)240-2400 • Fax (636)272-2408 • (800)325-6152 • Intl Fax# (001)636-272-7546  
 Parts Dept. (800)424-TRUE • Parts Dept. Fax# (636)272-9471 • www.truemfg.com

Project Name: \_\_\_\_\_

Location: \_\_\_\_\_

Item #: \_\_\_\_\_ Qty: \_\_\_\_\_

Model #: \_\_\_\_\_

A/A #

SIS #

Model:  
**GDM-49W-RF**

**Glass Door Wine Merchandiser:**  
*Swing Door Radius Front Refrigerator*



**GDM-49W-RF**

- ▶ The world's #1 manufacturer of glass door merchandisers.
- ▶ Oversized, factory balanced, refrigeration system holds 33°F to 38°F (.5°C to 3.3°C).
- ▶ Exterior - non-peel or chip black laminated vinyl; durable and permanent.
- ▶ Interior - attractive, NSF approved, black aluminum interior sides and top liner with 300 series stainless steel floor. Mirrored back wall.
- ▶ Self closing doors. Positive seal, torsion type closure system.
- ▶ "Low-E", double pane thermal insulated glass door assemblies with mitered plastic channel frames. The latest in energy efficient technology.
- ▶ Patented integrated door light (IDL) system for brighter, shadow free illumination.
- ▶ Entire cabinet structure is foamed-in-place using Ecomate. A new, innovative, high density, polyurethane insulation that has zero ozone depletion potential (ODP) and zero global warming potential (GWP).
- ▶ Eight (8) adjustable wine racks and two (2) adjustable, heavy duty PVC coated wire shelves.

**Bottom mounted units feature**

- ▶ "No stoop" lower shelf to maximize product visibility.
- ▶ Storage on top of cabinet.
- ▶ Easily accessible condenser coil for cleaning.

**ROUGH-IN DATA**

Specifications subject to change without notice.  
 Chart dimensions rounded up to the nearest 1/8" (millimeters rounded up to next whole number).

Model	Doors	Shelves		Cabinet Dimensions (inches) (mm)			HP	Voltage	Amps	NEMA Config.	Cord Length (total ft.) (total m)	Crated Weight (lbs.) (kg)
		Wire	Wine	L	D†	H						
GDM-49W-RF	2	2	8	54 1/8	34 3/4	78 5/8	1/2	115/60/1	7.3	5-15P	9	495
				1375	883	1998	1/2	230-240/50/1	5.4	▲	2.74	225

† Depth does not include 1 1/8" (29 mm) for door handles.

▲ Plug type varies by country.

	<b>APPROVALS:</b>  	<b>AVAILABLE AT:</b>  
3/11	Printed in U.S.A.	

Model:  
**GDM-49W-RF**

## Glass Door Wine Merchandiser: Swing Door Radius Front Refrigerator



### STANDARD FEATURES

#### DESIGN

- True's commitment to using the highest quality materials and oversized refrigeration systems provides the user with colder product temperatures, and lower utility costs in an attractive merchandiser that brilliantly displays wine and alcohol products.

#### REFRIGERATION SYSTEM

- Factory engineered, self-contained, capillary tube system using environmentally friendly (CFC free) 134A refrigerant.
- Extra large evaporator coil balanced with higher horsepower compressor and large condenser; maintains cabinet temperature of 33°F to 38°F (5°C to 3.3°C).
- Sealed, cast iron, self-lubricating evaporator fan motor(s) and larger fan blades give True merchandisers a more efficient low velocity, high volume airflow design. This unique design ensures faster temperature pull down of warm product, colder holding temperatures and faster recovery in high use situations.
- Bottom mounted condensing unit positioned for easy maintenance. "No stoop" lower shelf maximizes visibility by raising merchandised product to higher level.

#### CABINET CONSTRUCTION

- Exterior - non-peel or chip black laminated vinyl; durable and permanent.
- Interior - attractive, NSF approved, black aluminum sides and top liner with 300 series stainless steel floor. Mirrored interior back.
- Insulation - entire cabinet structure is foamed-in-place using Ecomate. A high density, polyurethane insulation that has zero ozone depletion potential (ODP) and zero global warming potential (GWP).
- Welded, heavy duty steel frame rail, black powder coated for corrosion protection.

- Frame rail fitted with leg levelers.
- Illuminated exterior sign panel. Variety of sign options available.

#### DOORS

- "Low-E", double pane thermal insulated glass door assemblies with mitered plastic channel frames. The latest in energy efficient technology.
- Each door fitted with 12" (305 mm) long extruded handle.
- Self closing doors. Positive seal, torsion type closure system.
- Magnetic door gaskets of one piece construction, removable without tools for ease of cleaning.

#### SHELVING

- Eight (8) adjustable wine racks 24½"L x 21⅙"D (623 mm x 535 mm) and two (2) adjustable, heavy duty PVC coated wire shelves 24⅞"L x 22⅞"D (624 mm x 562 mm). Four (4) chrome plated shelf clips included per rack and shelf.
- Shelf support pilasters made of same material as cabinet interior; shelves are adjustable on ½" (13 mm) increments.

#### LIGHTING

- Low UV emitting fluorescent interior lighting. Door utilizes full-length, patented, integrated door light (IDL) system. Safety shielded.
- Cabinet lighting utilizes electronic ballast and T-8 bulbs for brighter illumination, longer bulb life and increased energy efficiency.

#### MODEL FEATURES

- Evaporator is epoxy coated to eliminate the potential of corrosion.
- See our website [www.truemfg.com](http://www.truemfg.com) for latest color and sign offerings.
- Convenient clean-out drain built in cabinet floor.

#### ELECTRICAL

- Unit completely pre-wired at factory and ready for final connection to a 115/60/1 phase, 15 amp dedicated outlet. Cord and plug set included.



115/60/1  
NEMA-5-15R

#### OPTIONAL FEATURES/ACCESSORIES

Upcharge and lead times may apply.

- 230 - 240V / 50 Hz.
- White exterior.
- Rosewood exterior.
- 6" (153 mm) standard legs.
- 6" (153 mm) seismic/flanged legs.
- 2½" (64 mm) diameter castors.
- Red wine thermostat.
- White wine thermostat.
- Chocolate thermostat.
- Padlock.
- Additional black wine racks.
- Additional black wire shelves.
- 1¼" (32 mm) pricing strips.
- Remote cabinets (condensing unit supplied by others; system comes standard with 404A expansion valve and requires R404A refrigerant). Consult factory technical service department for BTU information. All remote units must be hard wired during installation.

### PLAN VIEW

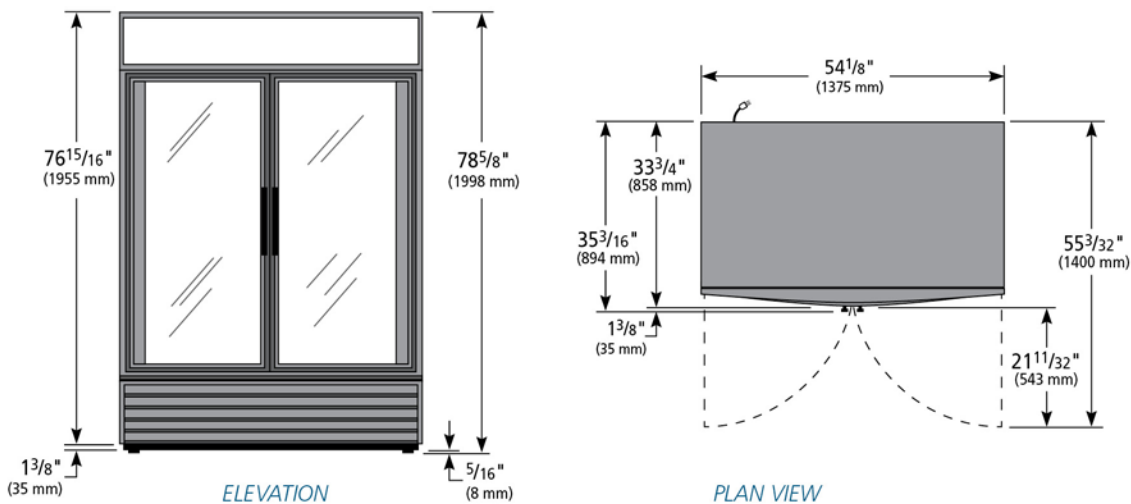

#### WARRANTY

One year warranty on all parts and labor and an additional 4 year warranty on compressor. (U.S.A. only)

METRIC DIMENSIONS ROUNDED UP TO THE NEAREST WHOLE MILLIMETER

SPECIFICATIONS SUBJECT TO CHANGE WITHOUT NOTICE



Model	Elevation	Right	Plan	3D	Back
GDM-49W-RF	TFD031E	TFD031S	TFD031P	TFD0313	

### TRUE FOOD SERVICE EQUIPMENT

2001 East Terra Lane • O'Fallon, Missouri 63366 • (636)240-2400 • Fax (636)272-2408 • (800)325-6152 • Intl. Fax# (001)636-272-7546 • [www.truemfg.com](http://www.truemfg.com)

KaTom Restaurant Supply, Inc.