



**TRUE FOOD SERVICE EQUIPMENT, INC.**

2001 East Terra Lane • P.O. Box 970 • O'Fallon, Missouri 63366  
 (636)240-2400 • Fax (636)272-2408 • (800)325-6152 • Intl Fax# (001)636-272-7546  
 Parts Dept. (800)424-TRUE • Parts Dept. Fax# (636)272-9471 • www.truemfg.com

Project Name: \_\_\_\_\_

Location: \_\_\_\_\_

Item #: \_\_\_\_\_ Qty: \_\_\_\_\_

Model #: \_\_\_\_\_

AIA #

SIS #

Model:  
**GDM-3**

**Glass Door Merchandiser:**  
Swing Door Counter-top Refrigerator



**GDM-3**

- ▶ The world's #1 manufacturer of glass door merchandisers.
- ▶ True's commitment to using the highest quality materials provides the user with colder product temperatures, and lower utility costs in an attractive merchandiser that brilliantly displays packaged food and beverages.
- ▶ Factory balanced, refrigeration system holds 38°F to 40°F (3.3°C to 4.4°C).
- ▶ Exterior - non-peel or chip black laminated vinyl; durable and permanent.
- ▶ Interior - attractive, NSF approved, white aluminum interior liner.
- ▶ Positive seal door.
- ▶ "Low-E", double pane thermal glass door assembly with mitered plastic channel frame. The latest in energy efficient technology.
- ▶ Entire cabinet structure is foamed-in-place using high density, CFC free, polyurethane insulation.
- ▶ Safety shielded fluorescent interior lighting for longer, brighter, shadow-free illumination.

**ROUGH-IN DATA**

Specifications subject to change without notice.  
 Chart dimensions rounded up to the nearest 1/8" (millimeters rounded up to next whole number).

Model	Doors	Capacity (Cu. Ft.) (liters)	Shelves	Cabinet Dimensions (inches) (mm)			HP	Voltage	Amps	NEMA Config.	Cord Length (total ft.) (total m)	Crated Weight (lbs.) (kg)
				L	D <sup>†</sup>	H						
GDM-3	1	4.4 125	2	19 483	19 <sup>7</sup> / <sub>8</sub> 505	33 <sup>7</sup> / <sub>8</sub> 861	1/8	115/60/1	2.5	5-15P	9 2.74	120 55

† Depth does not include 2<sup>1</sup>/<sub>8</sub>" (54 mm) for mechanical components and 1<sup>3</sup>/<sub>8</sub>" (35 mm) for door handle.

12/07 Printed in U.S.A.

APPROVALS:

AVAILABLE AT:

Model:  
**GDM-3**

**Glass Door Merchandiser:**  
Swing Door Counter-top Refrigerator



**STANDARD FEATURES**

**DESIGN**

- True's commitment to using the highest quality materials provides the user with colder product temperatures, and lower utility costs in an attractive merchandiser that brilliantly displays packaged food and beverages.

**REFRIGERATION SYSTEM**

- Factory engineered self-contained, capillary tube system using environmentally friendly (CFC free) 134A refrigerant.
- Designed to maintain cabinet temperatures of 38°F to 40°F (3.3°C to 4.4°C).

**CABINET CONSTRUCTION**

- Exterior - non-peel or chip black laminated vinyl; durable and permanent.
- Interior - attractive, NSF approved, white aluminum liner.
- Insulation - entire cabinet structure is foamed-in-place using high density, CFC free, polyurethane insulation.
- Cabinet fitted with 1 1/4" H (32 mm) rubber footed legs.
- Door sign decal. Variety of decal options available.

**DOOR**

- "Low-E", double pane thermal glass door assembly with mitered plastic channel frame. The latest in energy efficient technology.
- Positive seal door.
- Magnetic door gasket of one piece construction, removable without tools for ease of cleaning.

**SHELVING**

- Two (2) adjustable, PVC coated wire shelves 16" L x 14 13/16" D (407 mm x 377 mm). Four (4) chrome plated shelf clips included per shelf.
- Shelf support pilasters made of same material as cabinet interior; shelves are adjustable on 1/2" (13 mm) increments.

**LIGHTING**

- Safety shielded fluorescent interior lighting.
- Cabinet lighting utilizes electronic ballast and T-8 bulbs for brighter illumination, longer bulb life and increased energy efficiency.

**MODEL FEATURES**

- Evaporator is coated to eliminate the potential of corrosion.
- See our website [www.truemfg.com](http://www.truemfg.com) for latest color and sign offerings.
- Listed under NSF-7 for the storage and/or display of packaged or bottled product.

**ELECTRICAL**

- Unit completely pre-wired at factory and ready for final connection to a 115/60/1 phase, 15 amp dedicated outlet. Cord and plug set included.



115/60/1  
NEMA-5-15R

**RECOMMENDED OPERATION CONDITIONS**

- Designed to operate in an air conditioned environment where temperatures do not exceed 75°F and 55% relative humidity.
- Unit should be installed away from direct sunlight, rapid air movement and extreme temperature change.

**OPTIONAL FEATURES/ACCESSORIES**

Upcharge and lead times may apply.

- White exterior.
- Additional bottom shelf.
- Barrel lock (factory installed).

**PLAN VIEW**

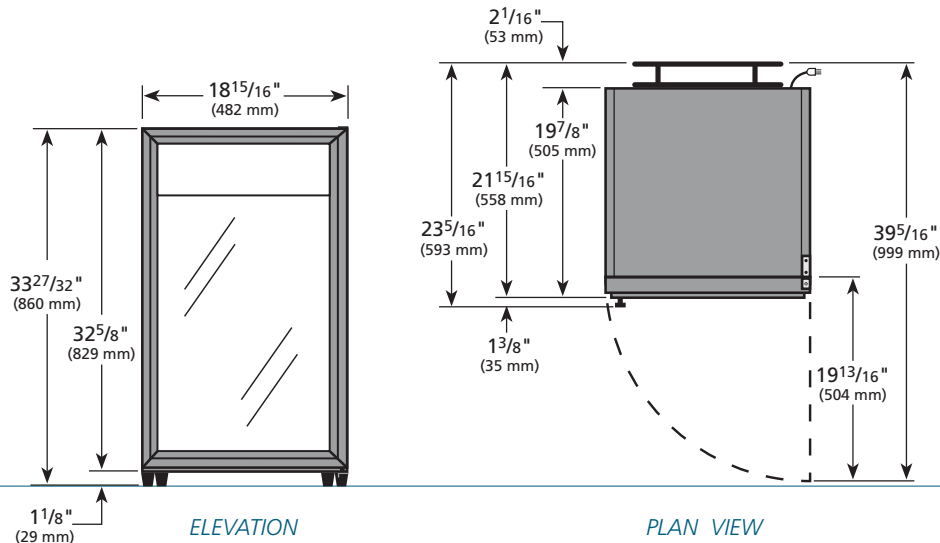

**WARRANTY**

One year warranty on all parts and labor and an additional 4 year warranty on compressor. (U.S.A. only)

METRIC DIMENSIONS ROUNDED UP TO THE NEAREST WHOLE MILLIMETER

SPECIFICATIONS SUBJECT TO CHANGE WITHOUT NOTICE



Model	Elevation	Right	Plan	3D
GDM-3				

**TRUE FOOD SERVICE EQUIPMENT**