



TRUE FOOD SERVICE EQUIPMENT, INC.

2001 East Terra Lane • P.O. Box 970 • O'Fallon, Missouri 63366
 (636)240-2400 • Fax (636)272-2408 • (800)325-6152 • Intl Fax# (001)636-272-7546
 Parts Dept. (800)424-TRUE • Parts Dept. Fax# (636)272-9471 • www.truemfg.com

Project Name: _____

Location: _____

Item #: _____ Qty: _____

Model #: _____

A/A #

S/S #

Model:
GDM-23W-RF

Glass Door Merchandiser:
Swing Door Radius Front Wine Refrigerator



GDM-23W-RF

- ▶ The world's #1 manufacturer of glass door merchandisers.
 - ▶ Oversized, factory balanced, refrigeration system holds 33°F to 38°F (5°C to 3.3°C).
 - ▶ Exterior - non-peel or chip black laminated vinyl; durable and permanent.
 - ▶ Interior - attractive, NSF approved, black aluminum interior sides and top liner with 300 series stainless steel floor. Mirrored back wall.
 - ▶ Self closing door. Positive seal, torsion type closure system. Door lock standard.
 - ▶ "Low-E", double pane thermal insulated glass door assembly with mitered plastic channel frame. The latest in energy efficient technology.
 - ▶ Patented integrated door light (IDL) system for brighter, shadow free illumination.
 - ▶ Entire cabinet structure is foamed-in-place using high density, CFC free, polyurethane insulation.
 - ▶ Four (4) adjustable wine racks and one (1) adjustable, heavy duty, black PVC coated wire shelf.
- Bottom mounted units feature**
- ▶ "No stoop" lower shelf to maximize product visibility.
 - ▶ Storage on top of cabinet.
 - ▶ Easily accessible condenser coil for cleaning.

Pictured with one additional (optional) wine rack, in lieu of one standard wire shelf.

ROUGH-IN DATA

Specifications subject to change without notice.
 Chart dimensions rounded up to the nearest 1/8" (millimeters rounded up to next whole number).

Model	Doors	Capacity (Cu. Ft.) (liters)	Shelves		Cabinet Dimensions (inches) (mm)			HP	Voltage	Amps	NEMA Config.	Cord Length (total ft.) (total m)	Crated Weight (lbs.) (kg)
			Wire	Wine	L	D	H						
GDM-23W-RF	1	23 651	1	4	27 686	31 1/4 794	78 5/8 1998	1/3 1/3	115/60/1 230-240/50/1	7.2 3.0	5-15P ▲	9 2.74	315 143

▲ Plug type varies by country.



APPROVALS:

AVAILABLE AT:

Model:
GDM-23W-RF

Glass Door Wine Merchandiser:
Swing Door Radius Front Refrigerator



STANDARD FEATURES

DESIGN

- True's commitment to using the highest quality materials and oversized refrigeration systems provides the user with colder product temperatures, and lower utility costs in an attractive merchandiser that brilliantly displays wine and alcohol products.

REFRIGERATION SYSTEM

- Factory engineered, self-contained, capillary tube system using environmentally friendly (CFC free) 134A refrigerant.
- Extra large evaporator coil balanced with higher horsepower compressor and large condenser; maintains cabinet temperature of 33°F to 38°F (.5°C to 3.3°C).
- Sealed, cast iron, self-lubricating evaporator fan motor(s) and larger fan blades give True merchandisers a more efficient low velocity, high volume airflow design. This unique design ensures faster temperature pull down of warm product, colder holding temperatures and faster recovery in high use situations.
- Bottom mounted condensing unit positioned for easy maintenance. "No stoop" lower shelf maximizes visibility by raising merchandised product to higher level.

CABINET CONSTRUCTION

- Exterior - non-peel or chip black laminated vinyl; durable and permanent.
- Interior - attractive, NSF approved, black aluminum sides and top liner with 300 series stainless steel floor. Mirrored interior back.
- Insulation - entire cabinet structure is foamed-in-place using high density, CFC free, polyurethane insulation.
- Welded, heavy duty galvanized frame rail dipped in rust inhibiting enamel paint for corrosion protection inside and out.

- Frame rail fitted with leg levelers.
- Illuminated exterior sign panel. Variety of sign options available.

DOOR

- "Low-E", double pane thermal insulated glass door assembly with mitered plastic channel frame. The latest in energy efficient technology. Door lock standard.
- Door fitted with 12" (305 mm) long extruded handle.
- Self closing door. Positive seal, torsion type closure system.
- Magnetic door gasket of one piece construction, removable without tools for ease of cleaning.

SHELVING

- Four (4) adjustable wine racks 22⁹/₁₆" L x 21¹/₈" D (574 mm x 537 mm) and one (1) adjustable, heavy duty, black PVC coated wire shelf 22⁹/₁₆" L x 23¹/₄" D (574 mm x 591 mm). Four (4) chrome plated shelf clips included per rack and shelf.
- Shelf support pilasters made of same material as cabinet interior; shelves are adjustable on 1/2" (13 mm) increments.

LIGHTING

- Safety shielded fluorescent interior lighting. Door utilizes full-length, patented, integrated door light (IDL) system.
- Cabinet lighting utilizes electronic ballast and T-8 bulbs for brighter illumination, longer bulb life and increased energy efficiency.

MODEL FEATURES

- Evaporator is epoxy coated to eliminate the potential of corrosion.
- See our website www.truemfg.com for latest color and sign offerings.

- Convenient clean-out drain built in cabinet floor.

ELECTRICAL

- Unit completely pre-wired at factory and ready for final connection to a 115/60/1 phase - 15 amp dedicated outlet. Cord and plug set included.



115/60/1
NEMA-5-15R

OPTIONAL FEATURES / ACCESSORIES

Upcharge and lead times may apply.

- 230-240V / 50 Hz.
- White exterior.
- Rosewood exterior.
- 6" (153 mm) standard legs.
- 6" (153 mm) seismic/flanged legs.
- 2¹/₂" (64 mm) diameter castors.
- Red wine thermostat.
- White wine thermostat.
- Chocolate thermostat.
- Sliding wine racks.
- Additional black wine racks.
- Additional black wire shelves.
- TrueTrac4 gravity feed organizers.
- 1¹/₄" (32 mm) pricing strips.
- Remote cabinets (condensing unit supplied by others; system comes standard with 404A expansion valve and requires R404A refrigerant). Consult factory technical service department for BTU information.

PLAN VIEW

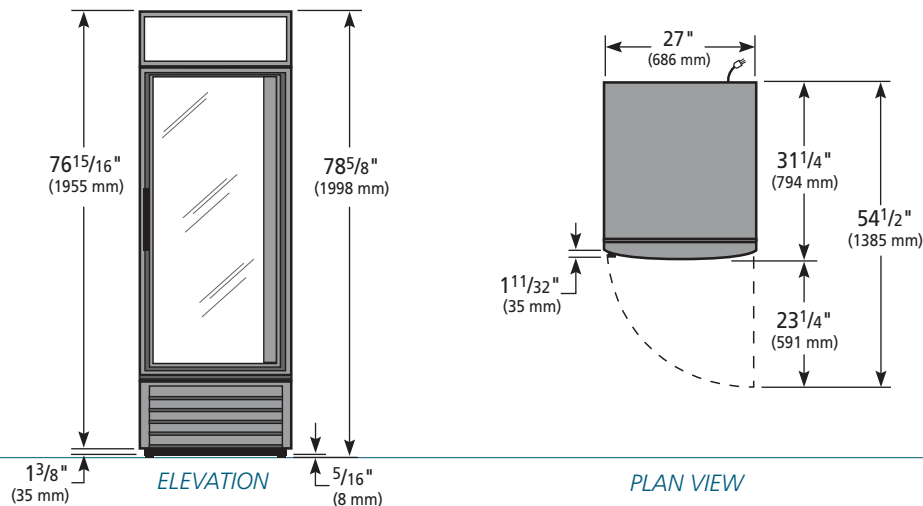

WARRANTY
One year warranty on all parts and labor and an additional 4 year warranty on compressor. (U.S.A. only)

METRIC DIMENSIONS ROUNDED UP TO THE NEAREST WHOLE MILLIMETER
SPECIFICATIONS SUBJECT TO CHANGE WITHOUT NOTICE



Model	Elevation	Right	Plan	3D
GDM-23W-RF	TFAY28E	TFAY28S	TFAY28P	TFAX283

TRUE FOOD SERVICE EQUIPMENT