



TRUE FOOD SERVICE EQUIPMENT, INC.

2001 East Terra Lane • P.O. Box 970 • O'Fallon, Missouri 63366
(636)240-2400 • Fax (636)272-2408 • (800)325-6152 • Intl Fax# (001)636-272-7546
Parts Dept. (800)424-TRUE • Parts Dept. Fax# (636)272-9471 • www.truemfg.com

Project Name: _____

A/A #

Location: _____

Item #: _____ Qty: _____

SIS #

Model #: _____

Model:
GDM-14RF

Glass Door Merchandiser: Radius Front Refrigerator



GDM-14RF

- ▶ The world's #1 manufacturer of glass door merchandisers.
 - ▶ Oversized, factory balanced, refrigeration system holds 33°F to 38°F (.5°C to 3.3°C).
 - ▶ Exterior - non-peel or chip white laminated vinyl; durable and permanent.
 - ▶ Interior - attractive, NSF approved, white aluminum interior liner with 300 series stainless steel floor.
 - ▶ Self closing doors. Positive seal, torsion type closing system.
 - ▶ "Low-E", double pane thermal insulated glass door assemblies with mitered plastic channel frames. The latest in energy efficient technology.
 - ▶ Fluorescent interior lighting for brighter, shadow free illumination.
 - ▶ Entire cabinet structure is foamed-in-place using high density, CFC free, polyurethane insulation.
- Bottom mounted units feature**
- ▶ "No stoop" lower shelf to maximize product visibility.
 - ▶ Storage on top of cabinet.
 - ▶ Easily accessible condenser coil for cleaning.

ROUGH-IN DATA

Specifications subject to change without notice.
Chart dimensions rounded up to the nearest 1/8" (millimeters rounded up to next whole number).

Model	Doors	Capacity (Cu. Ft.) (liters)	Shelves	Cabinet Dimensions (inches) (mm)			HP	Voltage	Amps	NEMA Config.	Cord Length (total ft.) (total m)	Crated Weight (lbs.) (kg)
				L	D†	H*						
GDM-14RF	2	14 396	3	30 ³ / ₈ 772	29 ¹ / ₄ 743	58 1474	1/3 1/3	115/60/1 230-240/50/1	7.9 4.0	5-15P ▲	9 2.74	295 134

† Depth does not include 1³/₈" (35 mm) for door handles.

* Height does not include 5/8" (16 mm) for appliance rollers.

▲ Plug type varies by country.



APPROVALS:

AVAILABLE AT:

Model:
GDM-14RF

Glass Door Merchandiser:
Radius Front Refrigerator



STANDARD FEATURES

DESIGN

- True's commitment to using the highest quality materials and oversized refrigeration systems provides the user with colder product temperatures, and lower utility costs in an attractive merchandiser that brilliantly displays packaged food and beverages.

REFRIGERATION SYSTEM

- Factory engineered, self-contained, capillary tube system using environmentally friendly (CFC free) 134A refrigerant.
- Extra large evaporator coil balanced with higher horsepower compressor and large condenser; maintains cabinet temperatures of 33°F to 38°F (.5°C to 3.3°C).
- Sealed, cast iron, self-lubricating evaporator fan motor(s) and larger fan blades give True merchandisers a more efficient low velocity, high volume airflow design. This unique design ensures faster temperature pull down of warm product, colder holding temperatures and faster recovery in high use situations.
- Bottom mounted condensing unit positioned for easy maintenance. "No stoop" lower shelf maximizes visibility by raising merchandised product to higher level.

CABINET CONSTRUCTION

- Exterior - non-peel or chip white laminated vinyl; durable and permanent.
- Interior - attractive, NSF approved, white aluminum liner with 300 series stainless steel floor.
- Insulation - entire cabinet structure is foamed-in-place using high density, CFC free, polyurethane insulation.

- Welded, heavy duty galvanized frame rail dipped in rust inhibiting enamel paint for corrosion protection inside and out.
- Frame rail fitted with 5/8" (16mm) appliance rollers.
- Illuminated exterior sign panel. Variety of sign options available.

DOORS

- "Low-E", double pane thermal insulated glass door assemblies with mitered plastic channel frames. The latest in energy efficient technology.
- Each door fitted with 12" (305 mm) long extruded handle.
- Self closing doors. Positive seal, torsion type closure system.
- Magnetic door gaskets of one piece construction, removable without tools for ease of cleaning.

SHELVING

- Three (3) adjustable, heavy duty PVC coated wire shelves 25^{11/16}" L x 20^{1/2}" D (574 mm x 521 mm). Four (4) chrome plated shelf clips included per shelf.
- Shelf support pilasters made of same material as cabinet interior; shelves are adjustable on 1/2" (13 mm) increments.

LIGHTING

- Safety shielded fluorescent interior lighting.
- Cabinet lighting utilizes electronic ballast and T-8 bulbs for brighter illumination, longer bulb life and increased energy efficiency.

MODEL FEATURES

- Evaporator is epoxy coated to eliminate the potential of corrosion.

- See our website www.truemfg.com for latest color and sign offerings.
- Convenient clean-out drain built in cabinet floor.
- Listed under NSF-7 for the storage and/or display of packaged or bottled product.

ELECTRICAL

- Unit completely pre-wired at factory and ready for final connection to a 115/60/1 phase - 15 amp dedicated outlet. Cord and plug set included.



115/60/1
NEMA-5-15R

OPTIONAL FEATURES/ACCESSORIES

Upcharge and lead times may apply.

- 230-240V / 50 Hz.
- Black exterior.
- Rosewood exterior.
- Black aluminum interior liner with black shelving.
- Red wine thermostat.
- White wine thermostat.
- Chocolate thermostat.
- Padlock.
- Additional shelves.
- TrueTrac4 gravity feed organizers.
- 1 1/4" (32 mm) pricing strips.
- Remote cabinets (condensing unit supplied by others; system comes standard with 404A expansion valve and requires R404A refrigerant). Consult factory technical service department for BTU information.

PLAN VIEW

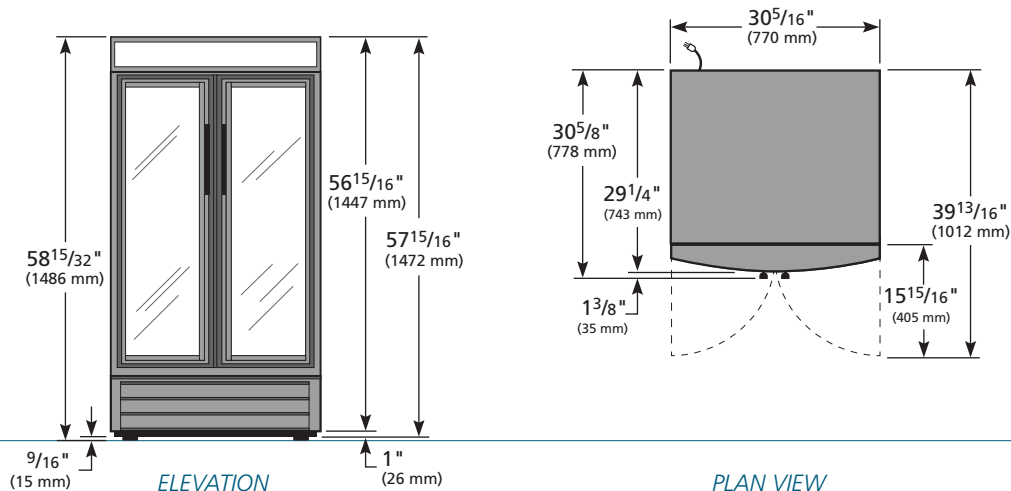

WARRANTY
One year warranty on all parts and labor and an additional 4 year warranty on compressor. (U.S.A. only)

METRIC DIMENSIONS ROUNDED UP TO THE NEAREST WHOLE MILLIMETER
SPECIFICATIONS SUBJECT TO CHANGE WITHOUT NOTICE

	Model	Elevation	Right	Plan	3D
	GDM-14RF	TFD028E	TFD028S	TFD028P	TFD0283

TRUE FOOD SERVICE EQUIPMENT