



THE TORNADO®



PERFORMANCE

- The Tornado® evenly and consistently toasts, browns and crisps food up to 12X faster than traditional cooking methods, resulting in a high level of throughput without compromising quality

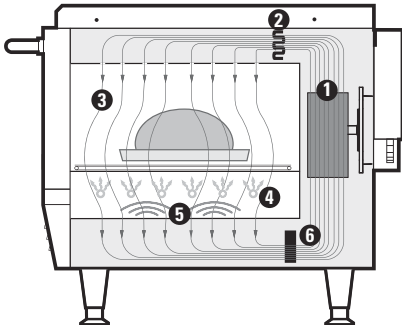

1. Blower Motor
2. Impingement Heater
3. Impinged Air
4. Bottom Browning Element
5. Microwave Bursts
6. Catalytic Converter

Project _____

Item No. _____

Quantity _____

EXTERIOR CONSTRUCTION

- 430 stainless steel front, top, sides and back
- 4" (102 mm) adjustable legs
- Cool to the touch pull down door with microwave seal

INTERIOR CONSTRUCTION

- 304 stainless steel interior
- Fully insulated cook chamber
- Removable / variable cooking surfaces
- Exposed bottom browning element

STANDARD FEATURES

- Integral recirculating catalytic converter for UL listed ventless operation (UL KNLZ)
- Variable-speed High h recirculating impingement airflow system
- Variable cooking surfaces (racks, stones and platters)
- Independently-controlled bottom browning element
- Smart Voltage Sensor Technology* (U.S. only)
- Smart menu system capable of storing up to 128 recipes
- Built-in self-diagnostics for monitoring oven components and performance
- Stackable design (requires stacking kit)
- Manual snooze mode
- Includes plug and cord (5 ft.)
- Warranty – 1 year parts and labor

COMES WITH STANDARD ACCESSORIES

- 1 Aluminum Paddle
- 1 Bottle Oven Cleaner
- 1 Bottle Oven Guard
- 2 Trigger Sprayers
- 2 Teflon Baskets
- 2 Teflon Sheets (International Only)
- 1 Standard Oven Rack



*Smart Voltage Sensor Technology does not compensate for lack of or over voltage situations. It is the responsibility of the owner to supply voltage to the unit according to the specifications on the back of this sheet. This product conforms to the ventilation recommendations set forth by NFPA96 using EPA202 test method.

If you have questions regarding ventless certifications or local codes please email ventless.help@turbochef.com. TurboChef reserves the right to make substitutions of components or change specifications without prior notice.

TurboChef Global Operations

4240 International Pkwy, Suite 105
 Carrollton, Texas 75007 USA
 US: 800.90TURBO (800.908.8726)
 International: +1 214.379.6000
 Fax: +1 214.379.6073
turbochef.com

NGC-1299/Revision F/
 March 2007

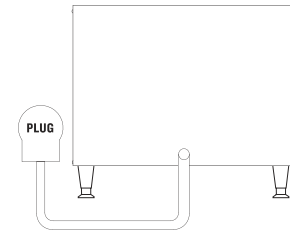
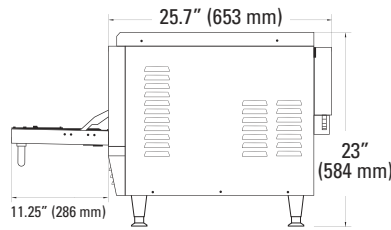
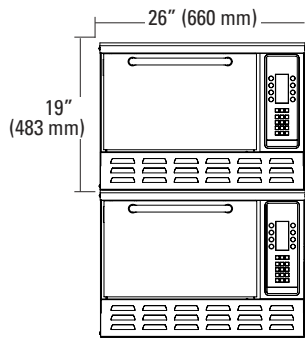

DIMENSIONS		
Single Units		
Height	19"	(483 mm)
on legs	23"	(584 mm)
Width	26"	(660 mm)
Depth	25.7"	(653 mm)
with handle	28.2"	(716 mm)
Weight	190 lbs.	(86 kg)
Stacked Units (Stacking Kit Required)		
Height	38"	(965 mm)
Width	26"	(660 mm)
Depth	25.7"	(653 mm)
with handle	28.2"	(716 mm)
Weight	380 lbs.	(172 kg)
Cook Chamber		
Height	8"	(203 mm)
Width	15.5"	(394 mm)
Depth	14.7"	(373 mm)
Volume	1.05 cu.ft.	(29.9 liters)
Wall Clearance (Oven not intended for built-in installation)		
Top	4"	(102 mm)
Sides	2"	(51 mm)
ELECTRICAL SPECIFICATIONS		
NORTH AMERICA		
NGC (NGC-1180-1)		
Phase	1 Phase	
Voltage	208/240 VAC	
Frequency	60 Hz	
Current	30 amp	
Plug/Cord	NEMA 6-30P; 1.5m, H07RN-F	
Max Input	5990/6675 watts	
Microwave Input Power	3500 watts	
NGCBK (NGC-1180-1K-2020)		
Phase	1 Phase	
Voltage	220 VAC	
Frequency	60 Hz	
Current	30 amp	
Plug	IEC 309, 3-pin, 32 amp	
Max Input	6700 watts	
Microwave Input Power	3500 watts	
EUROPE/ASIA-PACIFIC		
NGCEW (NGC-1180-1W for standard) NGCEW (NGC-1180-1W-2024 for Australia/New Zealand)* NGCKW (NGC-1180-1W-2004 for South Korea)**		
Phase	3 Phase	
Voltage	400 VAC	
Frequency	50 Hz or 60 Hz**	
Current	16 amp	

Plug	IEC 309, 5-pin, 32 amp		
Max Input	10500 watts		
Microwave Input Power	3500 watts		
NGCED (NGC-1180-1D)			
Phase	3 Phase		
Voltage	230 VAC		
Frequency	50 Hz		
Current	30 amp		
Plug	IEC 309, 4-pin, 32 amp		
Max Input	10500 watts		
Microwave Input Power	3500 watts		
NGCUK (NGC-1180-1K)			
Phase	1 Phase		
Voltage	230 VAC		
Frequency	50 Hz		
Current	30 amp		
Plug	IEC 309, 3-pin, 32 amp		
Max Input	6700 watts		
Microwave Input Power	3500 watts		
JAPAN			
NGCJD - 50Hz/ 3 Phase (NGC-1180-1D-2005-1) NGCJD - 60Hz/ 3 Phase (NGC-1180-1D-2005-2) NGCJK - 50Hz/ 1 Phase (NGC-1180-1K-2005-3) NGCJK - 60Hz/ 1 Phase (NGC-1180-1K-2005-4)			
Phase	1 or 3 Phase		
Voltage	200 VAC		
Frequency	50 or 60 Hz		
Current	30 amp		
Plug	PSE-marked, 3 or 4-blade, 30 amp		
Max Input	10500 or 6700 watts		
Microwave Input Power	3500 watts		

*All AU-New Zealand ovens with clips allow for 5 pin plug.

TurboChef recommends installing a type D circuit breaker for all installations.

SHIPPING INFORMATION	
U.S.: All ovens shipped within the U.S. are packaged in a double-wall corrugated box banded to a wooden skid.	
International: All International ovens shipped via Air or Less than Container Loads are packaged in wooden crates.	
Box size: 34" x 30" x 30" (864mm x 762mm x 762mm)	
Crate size: 36.5" x 32.5" x 31.5" (927mm x 826mm x 800mm)	
Item class: 85 NMFC #26770 HS code 8419.81	
Approximate crated weight: 310 lbs. (141 kg)	
Minimum entry clearance required for box: 30" (762mm)	
Minimum entry clearance required for crate: 31.5" (800mm)	