

SPEC # _____

QUANTITY _____

APPLICATION

COLD BEVERAGE

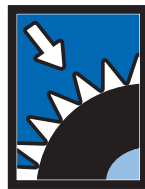

AT A GLANCE

Aqua-Pure® Models BEV190 and BEV195 single-cartridge water filtration systems provide the taste, appearance, and consistency of your beverages at flow rates to 5 gpm (18.9 lpm).

- **BEV190** combines cyst and bacteria reduction with sediment and chlorine taste and odor reduction for up to 54,000 gallons (204,000 liters).
- **BEV195** combines sediment removal from higher turbidity water with chlorine taste and odor removal for up to 54,000 gallons (204,412 liters).

PRODUCT BENEFITS

- Purified water for consistent high-quality beverages and continued customer satisfaction.
- Revolutionary Integrated **Membrane Pre-Activated Carbon Technology ("IMPACT")** dual-zone media cartridge construction combines a membrane in series with premium activated carbon to provide superior throughput and cartridge life.
- Cartridge Life Guarantee*.
- Certified by NSF to Standard 53 for cyst reduction (BEV190 system).
- NSF Standard 42 and/or FDA CFR-21 compliance provides assurance of safety.
- The removal of over 99.99% of common water-borne heterotrophic bacteria** by membrane filtration as tested by CUNO (BEV190 system).
- The removal of sediment and abrasive hard particles prevents wear and extends the life of pumps, valves, o-rings, and seals.
- The SQC – Sanitary Quick Change – encapsulated cartridge design allows for FAST and easy cartridge change-outs with a 1/4 turn while minimizing the possibility of leakage and contamination.
- System includes a pressure gauge and inlet shutoff valve for simple installation and operation.
- 3/8" FNPT horizontal inlet and outlet ports allow direct or easily adaptable connections to existing plumbing lines.
- Exhausted cartridges may be incinerated.

PRODUCT SPECIFICATIONS

Model Number	Part Number	Reduction Claims	Micron Rating	Capacity	Service Flow Rate	Application	Replacement Cartridge	Sizing
BEV190	56164-01	Cyst, Bacteria, Sediment, Chlorine Taste and Odor	0.2'	54,000 gallons (204,412 liters)	5 gpm (18.9 lpm)	Most Standard Water	HF90: 56135-03	Serves Carbonator and Cold Beverage Dispensers up to 5 gpm (18.9 lpm)
BEV195	56164-02	Sediment, Chlorine Taste and Odor	3.0	54,000 gallons (204,412 liters)	5 gpm (18.9 lpm)	Higher Turbidity Water	HF95: 56135-07	Serves Carbonator and Cold Beverage Dispensers up to 5 gpm (18.9 lpm)

* See Aqua-Pure Commercial Products Price Book for Terms and Conditions

** As tested with either E. Coli ATCC (11229) or Pseudomonas (B) diminuta ATCC (19146)

† NSF Certified for Particulate, Class I



a 3M company



Aqua-Pure® Commercial Products

SPEC # _____
QUANTITY _____
MODEL NUMBER _____
PART NUMBER _____

Aqua-Pure®
COMMERCIAL PRODUCTS
BEV190/BEV195

PHYSICAL SPECIFICATIONS

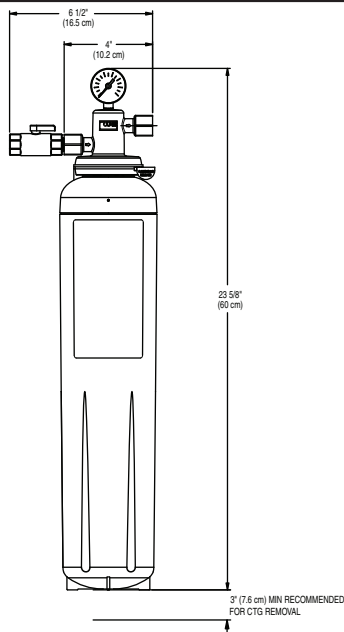

- System includes a head assembly with pressure gauge, inlet-water shutoff valve, mounting bracket, and single cartridge filter.
- Inlet and outlet plumbing connections are 3/8" FNPT.
- Filter cartridges are double o-ring seal type.
- System maximum operating pressure of 125 psi (862 kPa) and a maximum operating temperature of 100°F (38°C).
- Recommended service flow rate is up to 5 gpm (18.9 lpm).
- Filter cartridges incorporate carbon block media protected by a pleated pre-filter membrane.
- System is NSF Standard 42 and/or CFR-21 compliant.
- Cartridge body is constructed from high-impact glass-filled polypropylene.
- Cartridges are sanitary in design, requiring no contact with the filter media during cartridge change-out.
- Filter cartridges require no pre-activation.
- A NSF Performance Data Sheet (PDS) is included.
- Shipping weight: 5.8 lbs (2.6 kg)

INSTALLATION TIPS

- Shut off downstream equipment prior to installation of the system.
- Choose mounting location to support full system weight when operating.
- Do not exceed operating parameters for temperature or pressure.
- Do not install outdoors.
- For commercial use only.
- Install on cold water line only.

LIMITED 5 YEAR WARRANTY

CUNO makes no guarantees or warranties, expressed or implied, including, but not limited to, any implied warranty of merchantability or fitness for a particular purpose or implied warranty arising out of a course of dealing, custom, or usage of trade whatsoever with respect to these instructions. CUNO shall not under any circumstances be liable to the recipient of these instructions for any direct, indirect, special, incidental, or consequential loss or damages (including, but not limited to, loss of profits, revenue, business, opportunity, or goodwill) resulting from or in any way related to these instructions or the recipient's non-adherence to these instructions, regardless of the legal or equitable theory under which such loss or damages are sought, including breach of warranty or contract, negligence or strict liability.

IMPORTANT: Do not use with water that is microbiologically unsafe or of unknown quality without adequate disinfection before or after the system. Systems certified for cyst reduction may be used on disinfected water that may contain filterable cysts. EPA Establishment Number 070595-CT-001.

"CAUTION" To reduce the risks associated with water leakage, which if not avoided, may result in property damage - check with your plumbing professional to verify that water pressure is less than 125 psi (862 kPa).

CUNO Incorporated recommends regularly scheduled maintenance and replacement of the filter cartridge(s) in order for the product to perform as advertised/sold. **Change the filter cartridge at least every 6 months.** CUNO shall not be liable for system failures due to improper maintenance.



Visit www.nsf.org for the claims associated with products that are NSF listed.



CUNO Incorporated

400 Research Parkway
Meriden, CT 06450, USA
Toll Free: 1.888.218.CUNO
Worldwide: 203.237.5541
Fax: 203.238.8701

www.cunofoodservice.com