

## FW-15 FRY WARMER ■

**Innovative** Fry Warmer triples fried food-holding time while enhancing flavor. Developed for the Quick Serve market and with applications in Retail and C-store, the Fry Warmer combines convection and radiant heat technologies to extend freshness for a variety of fried foods including nuggets, fingers, fries and wedges.

Keep fried foods moist and delicious for up to 20 minutes without drying or creating a limp product. Features include an overheat safety system, reliable ceramic heating elements and easily removable pans. Everything works together to deliver consistent results and significant savings.



### STANDARD FEATURES

- o Triples Holding Time of Fried Food
- o Practical Configurations Provide Flexibility
- o Safety Cutoff Feature
- o Removable Parts for Easy Cleaning
- o Lighted Canopy Allows for Visually Pleasing Display

### OPTIONS FOR SPECIFICATION

- o Countertop or In-counter Mounting
- o 12" or 15" Width
- o Pass-thru or Solid Back



Specifications subject to change without notice.



#### BKI North America

P.O. Box 80400 • Simpsonville, SC 29680  
Tel: (864) 963-3471 • (800) 927-6887 • Fax: (864) 967-2787

#### BKI Europe

Tel: +(44) 01189 508222  
Fax: +(44) 01189 560233

[www.bkideas.com](http://www.bkideas.com)

# FW-15 FRY WARMER

# SPECIFICATIONS

## DIMENSIONS

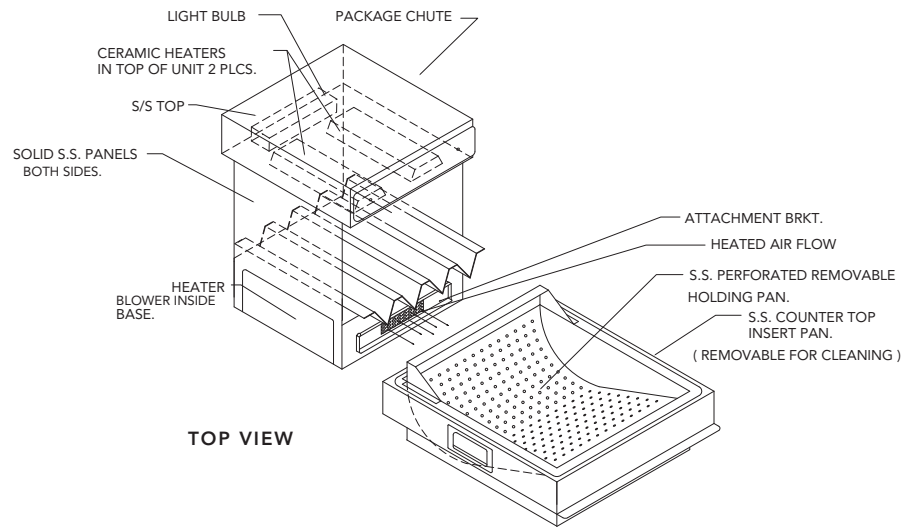

TOP VIEW

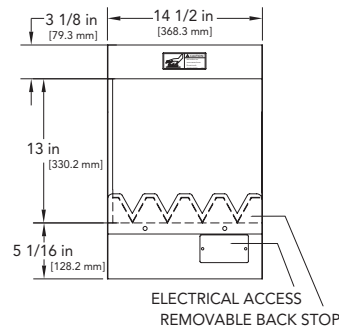

FRONT VIEW

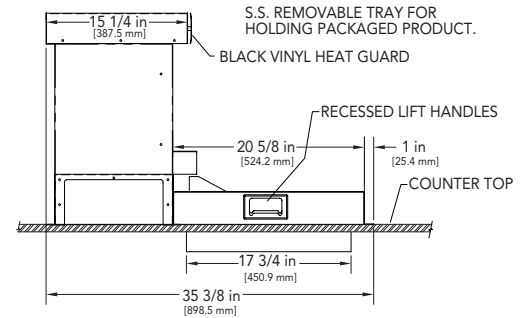

LEFT SIDE VIEW

## FLOOR SPACE

4.58 sq.ft. (.43 m<sup>2</sup>)

## CAPACITY

FW-12: 8 lb. of product  
FW-15: 10lb. of product

## HEATING FORMAT

Convection & Radiant Heat

## SHIPPING WEIGHT

66 lb. (30 kg.)

## ELECTRICAL

## ELECTRICAL SPECIFICATIONS

Volts	Amps	Breaker	KW	Phase
120	15.4	20	1.84	1
220	8.8	15	1.84	1

© BKI LI0045 4-04 Specifications subject to change without notice.



## BKI North America

P.O. Box 80400 • Simpsonville, SC 29680  
Tel: (864) 963-3471 • (800) 927-6887 • Fax: (864) 967-2787

## BKI Europe

Tel: +(44) 01189 508222  
Fax: +(44) 01189 560233

www.bkideas.com