

BLENDING STATION® ADVANCE

FEATURES

- 34 optimized programs with automatic shut-off
- Compact sound-abatement cover with unique cover hinge design
- Fully programmable
- XP Container and patented Blade
- Low & high speed pulse control
- Variable speed control
- Advanced technology 3 HP* motor designed for demanding smoothie and coffee shops

BENEFITS

- Keep customers coming back for your consistently smooth, delicious frozen drinks
- Combine the most difficult-to-blend ingredients with ease and speed
- No overblending or wasted ingredients
- Save counter space
- Minimize blender noise and maintain ambience
- Smooth opening and closing of cover with no fear of it slamming shut
- Optimize blender for your signature drinks
- Homogenize extra thick ingredients completely for smooth, creamy drinks
- Reduce blending time, increase drink volume and profits
- Quickly refresh drinks
- Operate machine manually for crushing ice or for non-programmed blending
- Ultimate flexibility in blending with choice of 93 speeds
- No overheating during peak volumes or when using extra thick ingredients

ON-COUNTER

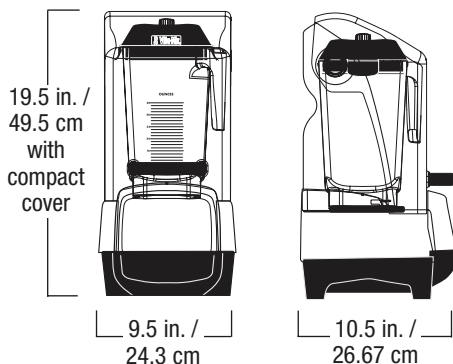

IN-COUNTER

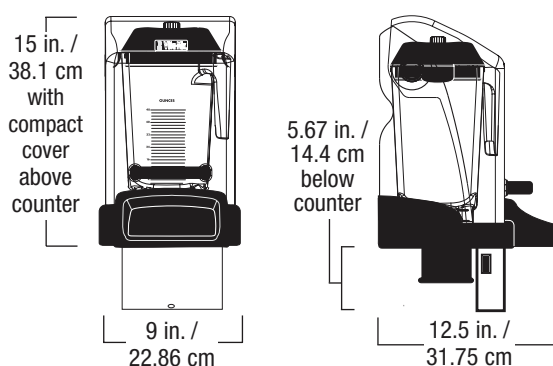

*Motor: 3 HP motor (varies slightly with voltage)

Pack: 1 per standard pack

On-Counter Weight: 19.5 lbs. / 8.9 kg

In-Counter Weight: 17.5 lbs. / 7.9 kg

On-Counter Case: 13.3 in. / 33.8 cm High x

12.1 in. / 30.7 cm Wide x 24.2 in. / 61.5 cm Deep

In-Counter Case: 12.1 in. / 30.7 cm High x

14.8 in. / 37.6 cm Wide x 24.9 in. / 63.2 cm Deep



For more information, contact your local foodservice distributor.

BLENDING STATION ADVANCE – with 48 oz. / 1.4 Ltr. XP Container and Blade – pre-programmed with 34 programs; removable compact cover hinge design.

Item # Description

36006	On-Counter Blending Station Advance, 120V, 50/60 Hz, 15 Amps
36201	On-Counter Blending Station Advance, 120V EMC, 50/60 Hz, 15 Amps
52001	On-Counter Blending Station Advance, 100V, 50/60 Hz, 1300 Watts
50003	On-Counter Blending Station Advance, 220-240V, 50/60 Hz, 1300-1550 Watts
40002	In-Counter Blending Station Advance, 120V, 50/60 Hz, 15 Amps
53001	In-Counter Blending Station Advance, 100V, 50/60 Hz, 1300 Watts
51003	In-Counter Blending Station Advance, 220-240V, 50/60 Hz, 1300-1550 Watts

WARRANTY AND SERVICE CONTRACT

In the United States and Canada, the Vita-Mix Blending Station Advance is backed by a three-year warranty against defects in parts and workmanship and includes a one-year service contract. Other warranties apply outside the United States and Canada. Contact your local Vita-Mix Distributor for details or telephone +1.440.782.2450 for a distributor near you.

www.vitamix.com/foodservice/blendingstation

800-4DRINK4



For a Dealer near you, contact Vita-Mix:

US, Canada and Latin America: PHONE: 440-235-0214;
FAX: 440-235-9670; EMAIL: foodservice@vitamix.com

For a Distributor in all other countries: TEL: +1.440.782.2450;
FAX: +1.440.782.2220; EMAIL: international@vitamix.com