



# Cyclone SERIES



**Model CO11-G1  
with optional casters**

## SPECIFICATIONS

Gas heated, forced air convection type oven. Standard specifications include 60,000 BTU/HR per cavity, 3/4" NPT rear gas connection, two speed fan powered by an energy saving 1/4 HP hi-low fan motor with a unique 900 RPM low speed setting, and a 4-second cycle hot surface ignition system. 150° F (65°C) to 550° F (285°C) temperature range.

Door interlock switch automatically turns the fan and ignition off when the oven door is open. A manual rotary control will turn the fan on when the door is open for quick cool-down. The 60-minute timer has a continuous ring with manual shut-off. An indicator light glows when the burner is on.

The oven interior measures 29" wide (737mm) by 20" high (508mm) by 22 1/2" deep (572mm) with a porcelain enamel finish over heavy gauge steel featuring a full sized cooking chamber with removable 11-position rack guide with 1 5/8" spacing and 5 heavy duty adjustable chrome-plated racks.

The oven exterior measures 39 3/8" wide (1000mm) by 38 3/8" deep (975) by 33 3/8" high (848mm). Front, top and sides are constructed with stainless steel. Single oven legs are 30" tall (6" for double), 7-gauge steel and finished with durable Baker Tone finish.

Dual doors are 55/45 split-type with double-pane thermal glass, synchronized operation, stainless steel seals and a single left mounted "Cool Touch" handle. Doors are fabricated with stainless steel inside-and-out, and fully insulated with 2" of industrial grade insulation.

Limited 2 year part & labor and 5 year door warranty.

Job \_\_\_\_\_ Item # \_\_\_\_\_

## GAS CONVECTION OVENS



- Model CO11-G1 Single**
- Model CO11-G2 Double**

## STANDARD FEATURES

- Energy efficient 60,000 BTU/HR oven indirect/direct forced air combination heat system
- Natural or propane gas, 120v or 208v-240v 60hz
- Electronic temperature control
- Electronic hot surface ignition system with safety shut-off
- Double-pane thermal glass door windows
- Oven lights
- 60-Minute continuous ring timer with manual shut-off
- 150°F (65°C) to 550°F (285°C) temperature range
- Energy efficient 1/4 HP two-speed fan motor
- Cool down fan mode
- Burner-on and temperature-ready indicator lights
- Porcelain enamel oven interior
- 11-Position removable rack guides with 1 5/8" spacing
- 5 Heavy-duty, positive-stop, chrome-plated wire racks
- Stainless steel front, top & sides
- 7-Gauge steel legs with durable Baker Tone finish
- Stainless steel, 55/45 split synchronized doors, with single left mounted handle
- Stainless steel door seals
- Front mounted, hinged control panel for easy service access
- 1/8" Welded angle iron frame construction
- Aluminized steel combustion chamber — flue included
- Heavy-duty industrial grade insulation in top, sides, back & doors
- Removable tube burners
- Front accessible manual gas shut-off valve

## OPTIONS & ACCESSORIES

- Steam injection with front panel controls
- Computerized programmable controls with LED display for integrated use of Cook & Hold, multi function cooking, fan speed, fan cycle and steam injection functions
- Open rack stand with rack supports
- 30" Stainless steel legs with undershelf
- Single connection external gas manifolds for double decks
- Heavy-duty caster set, two with caster locks
- 48" Quick-disconnect gas hoses with restraining cables
- Stainless steel perforated rear panel
- Solid Doors
- Correctional Facility package
- International voltages, 50hz

## CERTIFICATIONS



BAKERS PRIDE OVEN COMPANY, INC.  
30 Pine Street, New Rochelle, NY 10801  
914/576-0200 • 1-800-431-2745 • fax 914/576-0605

*Continuous product improvement is a policy of Bakers Pride Oven Company. Therefore, specifications and design are subject to change without notification*

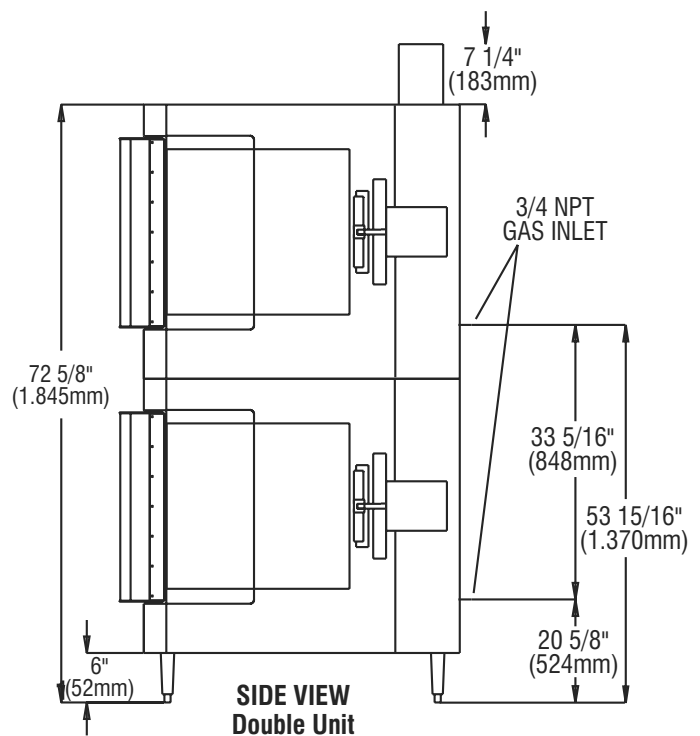
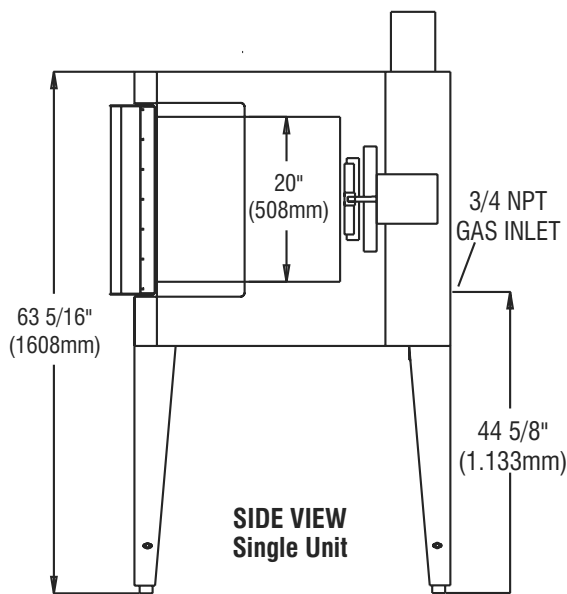
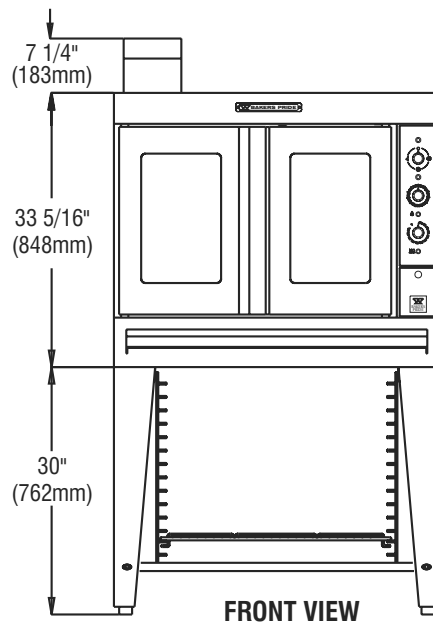
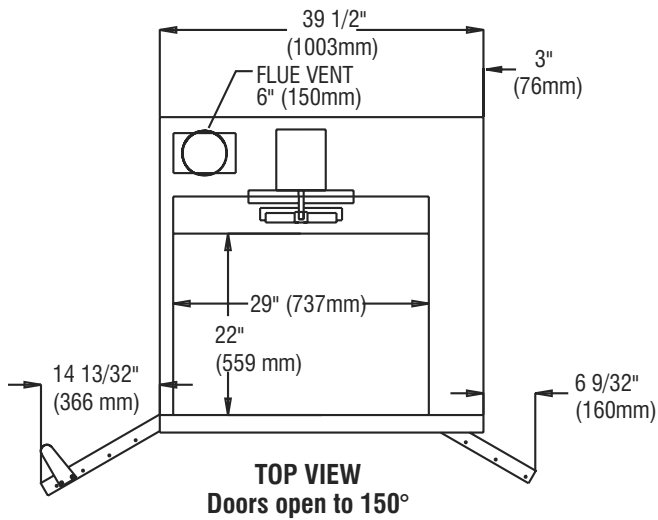

ALL DIMENSIONS NOMINAL

**SHIPPING INFORMATION**

Model	Shipping Weight		Carton Size		Carton Dimensions					
	Lbs.	Kilos	Cubic Feet	Cubic Meters	Width		Depth		Height	
	Inches	MM	Inches	MM	Inches	MM	Inches	MM	Inches	MM
CO11-G1	660	349	43.5	1.23	43.5	1105	46.0	1168	37.5	952
CO11-G2	Shipped in two cartons as per above specifications									

**POWER SUPPLY**

Model	BTUH	KW	HZ	Voltage 1Ø	Amps	Wire	Phase	RPM-low	RPM-high
CO11-G1	60,000	17.58	60	115	7.5	2	1	900	1,725
CO11-G1	60,000	17.58	60	208/240	4	2	1	1,140	1,725
CO11-G1	60,000	17.58	50	230	4	2	1	950	1,425
CO11-G2	120,000	35.16	60	115	2 x 7.5	2	1	900	1,725
CO11-G2	120,000	35.16	60	208/240	2 x 4	2	1	1,140	1,725
CO11-G2	120,000	35.16	50	230	2 x 4	2	1	950	1,425

**GAS SUPPLY — 3/4" NPT rear connection**

Gas Type	Manifold Pressure		Inlet Pressure	
	WC	Mbar	Inches	Mbar
Natural	3.5"	9 min	7"	17.5 min
Propane			11"	27.5 min
	10"	25 max	13"	32.5 max

Separate gas connections or external manifold required for stacked ovens

**MINIMUM CLEARANCES**

	Vent Hood		Direct Venting	
	Inches	MM	Inches	MM
Right	1	25	1	25
Left	1	25	3	76
Rear	3	76	3	76

Suitable for installation on combustible floors when installed on factory supplied legs or casters



BAKERS PRIDE OVEN COMPANY, INC.  
30 Pine Street, New Rochelle, NY 10801  
914/576-0200 • 1-800-431-2745 • fax 914/576-0605

Continuous product improvement is a policy of Bakers Pride Oven Company. Therefore, specifications and design are subject to change without notification  
TS: 3M 11/04