



U Series 60" Raised Griddle/Broiler Gas Range

Item: _____
 Quantity: _____
 Project: _____
 Approval: _____
 Date: _____

U Series 60" Raised Griddle/Broiler Gas Range

Models:

- U60-6R24RR U60-6R24RS U60-6R24SS



Model U60-6RR24RR

NOTE: Ranges supplied with casters must be installed with an approved restraining device.

Standard Features:

- Large 27" (686mm) work top surface
- Stainless steel front and sides
- Stainless steel 5" (127mm) plate rail
- Stainless steel backguard, w/removable stainless steel shelf
- 6" (152mm) adj. stainless steel legs
- Large easy-to-use control knobs
- Gas regulator
- 12" (305mm) section stamped drip trays w/ dimpled bottom
- Ergonomic split cast iron top ring grates
- Powerful 32,000 Btuh/ 9.37 kW, 2 piece cast iron geometric open top burner
- 24" (610mm) raised griddle/broiler section W/ 3 cast iron burners each rated 11,000 Btuh/3.22 kW, w/one manual hi/lo valve per burner
- 5/8" (15mm) thick steel griddle plate w/manual hi/lo valve control, 23" (584mm) working depth surface
- 4-1/4" 108(mm) wide grease trough
- 38,000 Btuh/ 11.13 kW cast iron "H" style oven burner
- Large oven w/porcelain ribbed bottom & door, aluminized steel top, sides and back; oven fits standard sheet pans in both directions for standard ovens
- Nickel plated oven rack and 3-position removable oven rack guide

- Strong, keep-cool oven door handle
- Snap action modulating oven thermostat low to 500° F
- Convection oven w/3 nickel plated oven racks and removable rack guides in lieu of standard oven w/ 1/3HP 120v 60 Hz single phase fan motor; change suffix RS to CS or RR to CC, CS ovens standard on right
- Cabinet base in lieu of oven

Optional Features:

- Convection oven motor 240v 50/60HZ single phase
- Hot top 12" (305mm) plate in lieu of two open burners, manual valve controlled w/20,000 Btuh/5.86 kW cast iron "H" burner standard on left side
- Stainless steel back for high shelf, or range
- Chef Oven Upgrade Package: fully porcelain oven w/ribbed hearth & door liner
- Additional oven racks
- 6" (152mm) swivel casters (4), w/front locking, leveling or non-leveling (specify)
- Flanged deck mount legs
- Stainless steel door for storage base models
- Intermediate stainless steel shelf for storage base models

Specifications:

Gas restaurant series range with large capacity (standard) oven. 59 1/16" (1500 mm) wide with a 27" (686mm) deep work top surfaces. Stainless steel front, sides and 5" wide front rail. 6" (152mm) legs with adjustable feet. Six powerful 2 piece 32,000 Btuh/9.37 kW (Natural Gas), cast open burners set in split cast iron ergonomic grates. 24" (610mm) raised griddle/broiler section with 3 cast iron burners each rated a 11,000 Btuh/3.22 kW. Optional hot-top with cast iron "H" style burners, 20,000 Btuh/5.86 kW (natural gas), in lieu of open burners. Porcelain oven bottom and door liner. Durable heavy duty oven door w/ "keep cool" handle. Heavy cast iron "H"

oven burner rated 38,000 Btuh/11.13 kW (natural gas) Oven controlled by even bake, fast recovery snap action modulating oven thermostat. Available with convection oven or storage base in lieu of standard oven.



Garland Commercial Industries, LLC
 185 East South Street
 Freeland, PA 18224
 Phone: (570) 636-1000
 Fax: (570) 636-3903

Garland Commercial Ranges Ltd
 1177 Kamato Road,
 Mississauga, Ontario
 L4W 1X4 CANADA
 Phone: 905-624-0260
 Fax: 905-624-5669

Enodis UK LTD
 Swallowfield Way,
 Hayes, Middlesex
 UB3 1DQ ENGLAND
 Telephone: 081-561-0433
 Fax: 081-848-0041

Enodis

Model Number	Description	Total BTU/Hr Natural	Shipping Information		
			Lbs.	Kg	Cu Ft
U60-6R24SS	6 Open Burners, 24" Raised Griddle/Broiler w/ Double Storage Base	225,000	662	300	81
U60-6R24RR ¹	6 Open Burners, 24" Raised Griddle/Broiler w/ (2) Standard Ovens	301,000	828	376	81
U60-6R24RS ¹	6 Open Burners, 24" Raised Griddle/Broiler w/ (1) Standard Ovens & Storage Base	263,000	787	357	81

¹ Available with convection oven change RS to CS for single with storage or RR to CC for two convection ovens

Width In (mm)	Depth ² In (mm)	Height w/shelf In (mm)	Oven Interior-in (mm)			Combustible Wall Clearance-In (mm)		Entry Clearances In (mm)		Manifold Operating Pressure	
			Height	Depth ³	Width	Sides	Rear	Crated	Uncrated	Natural	Propane
59-1/16 (1500)	34-1/2 (876)	57 (1448)	13 (330)	26 (660)	26-1/4 (667)	12 (305)	6 (152)	37 (940)	36-1/2 (927)	4.5" WC 11 mbar	10" WC 25 mbar

² Convection oven base models add 3 7/8" (98mm) to the depth of the unit. ³ Convection oven depth 22" (559mm)

Gas input ratings shown for installations up to 2000 ft.,(610m) above sea level. Please specify altitudes over 2000 ft.

Burner Ratings (BTU/Hr/kW)				
Gas Type	Open Top	Hot Top	Standard Oven or Convection	Raised Griddle/Broiler
Natural	32,000/9.37	20,000/5.8	38,000/11.13	33,000/9.66
Propane	26,000/7.61	19,000/5.56	32,000/9.38	33,000/9.66

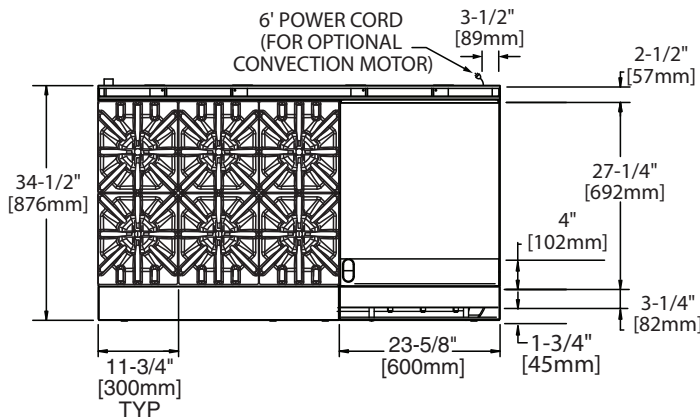

Note: Installation clearance reductions are applicable only where local codes permit. This product is not approved for residential use. Convection ovens with 120V, 60 Hz, 1 phase, 3.4 amps motors are supplied with 6'/1829mm cord and plug (NEMA 5-15P); 240V ,50/60 Hz, 1 phase motors are not supplied with cord and plug and must have direct connect.

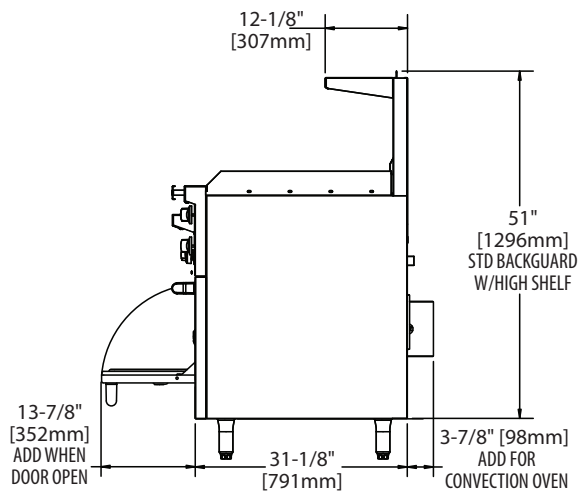
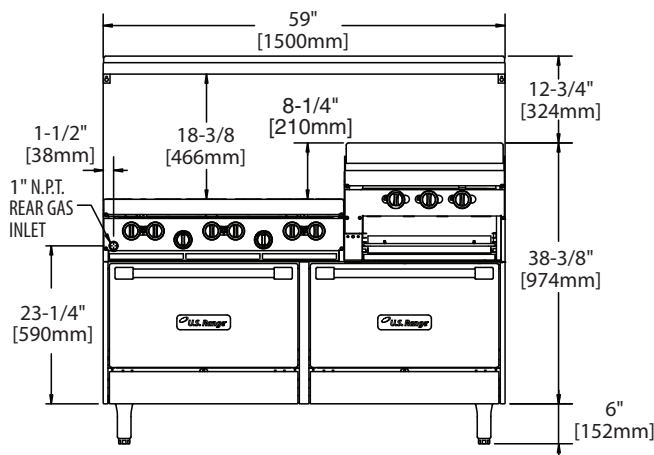

Form# URB60 Series (04/02/08)