



# U Series 60" Gas Restaurant Range

Item: \_\_\_\_\_  
 Quantity: \_\_\_\_\_  
 Project: \_\_\_\_\_  
 Approval: \_\_\_\_\_  
 Date: \_\_\_\_\_

U Series 60" Gas Restaurant Range

**Models:**

- |                                   |                                     |                                     |                                     |                                     |                                    |
|-----------------------------------|-------------------------------------|-------------------------------------|-------------------------------------|-------------------------------------|------------------------------------|
| <input type="checkbox"/> U60-10RR | <input type="checkbox"/> U60-8G12RR | <input type="checkbox"/> U60-6G24RR | <input type="checkbox"/> U60-4G36RR | <input type="checkbox"/> U60-2G48RR | <input type="checkbox"/> U60-G60RR |
| <input type="checkbox"/> U60-10RS | <input type="checkbox"/> U60-8G12RS | <input type="checkbox"/> U60-6G24RS | <input type="checkbox"/> U60-4G36RS | <input type="checkbox"/> U60-2G48RS | <input type="checkbox"/> U60-G60RS |
| <input type="checkbox"/> U60-10SS | <input type="checkbox"/> U60-8G12SS | <input type="checkbox"/> U60-6G24SS | <input type="checkbox"/> U60-4G36SS | <input type="checkbox"/> U60-2G48SS | <input type="checkbox"/> U60-G60SS |



*Model U60-10RR*

NOTE: Ranges supplied with casters must be installed with an approved restraining device.

**Standard Features:**

- Large 27" (686mm) work top surface
- Stainless steel front and sides
- Stainless steel 5" (127mm) plate rail
- Stainless steel backguard, w/removable stainless steel shelf
- 12" (305mm) section stamped drip trays w/ dimpled bottom
- 6" (152mm) adj. stainless steel legs
- Large easy-to-use control knobs
- Gas regulator

**Standard on Applicable Models:**

- Cabinet base in lieu of oven
- Ergonomic split cast iron top ring grates
- Powerful 32,000 Btuh/ 9.37 kW 2 piece cast iron geometric open top burner
- 5/8" (15mm) thick steel griddle plate w/manual hi/lo valve control, 23" (584mm) working depth surface, Standard on right, optional on left
- 4-1/4" (108mm) wide grease trough
- 20,000 Btuh/5.86 kW cast iron "H" style griddle burner per 12"(305mm) width of griddle
- 38,000 Btuh/ 11.13 kW cast iron "H" style oven burner
- Snap action modulating oven thermostat low to 500° F
- Large oven w/porcelain ribbed bottom & door, aluminized steel top, sides and back; oven fits standard sheet pans in both directions for standard ovens
- Nickel plated oven rack and 3-position removable oven rack guide

- Strong, keep-cool oven door handle
- Convection oven w/3 nickel plated oven racks and removable rack guides in lieu of standard oven w/ 1/3HP 120v 60 Hz single phase fan motor; change suffix RS to CS or RR to CR (1) or CC (2) convection ovens, CR or CS ovens standard on right

**Optional Features:**

- Convection oven motor 240v 50/60HZ single phase
- Snap action modulating griddle control 175° to 425° F
- Grooved griddle in 1/2 or full plate section widths
- Hot top 12" (305mm) plate in lieu of two open burners, manual valve controlled w/20,000 Btuh/5.86 kW cast iron "H" burner standard on left side
- Low profile 6" (152mm) backguard stainless steel front and sides
- Stainless steel back for high shelf, low profile backguard or range
- Chef Oven Upgrade Package: fully porcelain oven w/ribbed hearth & door liner
- Additional oven racks
- 6" (152mm) swivel casters (4), w/front locking, leveling or non-leveling (specify)
- Flanged deck mount legs
- Stainless steel door for storage base models
- Intermediate stainless steel shelf for storage base models

**Specifications:**

Gas restaurant series range with deep capacity oven. 59-1/16" (1500mm) wide with 27" (686mm) deep work top surfaces. Stainless steel front, sides and 5" wide front rail. 6" (152mm) legs with adjustable feet. Ten powerful 2 piece 32,000 Btuh/9.37 kW (Natural Gas), cast open burners set in split cast iron ergonomic grates. Griddle or optional hot-top with cast iron "H" style burners, 20,000 Btuh/5.86 kW (natural gas), in lieu of open burners. Porcelain oven bottom and door

liner. Durable heavy duty oven door w/ "keep cool" handle. Heavy cast iron "H" oven burner rated 38,000 Btuh/11.13 kW (natural gas) Oven controlled by even bake, fast recovery snap action modulating oven thermostat. Available with convection oven or storage base in lieu of standard oven(s).



**Garland Commercial Industries, LLC**  
 185 East South Street  
 Freeland, PA 18224  
 Phone: (570) 636-1000  
 Fax: (570) 636-3903

**Garland Commercial Ranges Ltd**  
 1177 Kamato Road,  
 Mississauga, Ontario  
 L4W 1X4 CANADA  
 Phone: 905-624-0260  
 Fax: 905-624-5669

**Enodis UK LTD**  
 Swallowfield Way,  
 Hayes, Middlesex  
 UB3 1DQ ENGLAND  
 Telephone: 081-561-0433  
 Fax: 081-848-0041



**OB=Open Burners      G=Griddle      O=Oven(s)**

**Shipping volume, all models=79 Cu Ft**

Model Number	OB	G	O	Total BTU/Hr Natural	Ship Wt.	
					Lbs.	Kg
U60-10RR <sup>1</sup>	10	—	(2) 26"	396,000	726	329
U60-10RS <sup>1</sup>	10	—	(1) 26"	358,000	690	312
U60-10SS	10	—	—	320,000	581	264
U60-8G12RR <sup>1</sup>	8	12"	(2) 26"	352,000	756	343
U60-8G12RS <sup>1</sup>	8	12"	(1) 26"	314,000	720	327
U60-8G12SS	8	12"	—	276,000	611	277
U60-6G24RR <sup>1</sup>	6	24"	(2) 26"	308,000	791	359
U60-6G24RS <sup>1</sup>	6	24"	(1) 26"	270,000	755	342
U60-6G24SS	6	24"	—	232,000	646	293

Model Number	OB	G	O	Total BTU/Hr Natural	Ship Wt.	
					Lbs.	Kg
U60-4G36RR <sup>1</sup>	4	36"	(2) 26"	264,000	826	375
U60-4G36RS <sup>1</sup>	4	36"	(1) 26"	226,000	790	358
U60-4G36SS	4	36"	—	188,000	681	309
U60-2G48RR <sup>1</sup>	2	48"	(2) 26"	220,000	851	386
U60-2G48RS <sup>1</sup>	2	48"	(1) 26"	182,000	815	370
U60-2G48SS	2	48"	—	144,000	706	320
U60-G60RR <sup>1</sup>	—	60"	(2) 26"	176,000	866	393
U60-G60RS <sup>1</sup>	—	60"	(1) 26"	138,000	830	376
U60-G60SS	—	60"	—	100,000	721	327

<sup>1</sup> Available with convection oven change RS to CS; RR to RC for one convection oven or CC for two convection ovens

Width In (mm)	Depth <sup>2</sup> In (mm)	Height w/shelf In (mm)	Oven Interior-in (mm)			Combustible Wall Clearance-In (mm)		Entry Clearances In (mm)		Manifold Operating Pressure	
			Height	Depth <sup>3</sup>	Width	Sides	Rear	Crated	Uncrated	Natural	Propane
59-1/16 (1500)	34-1/2 (876)	57 (1448)	13 (330)	26 (660)	26-1/4 (667)	12 (305)	6 (152)	37 (940)	36-1/2 (927)	4.5" WC 11 mbar	10" WC 25 mbar

<sup>2</sup> Convection oven base models add 3 7/8" (98mm) to the depth of the unit. <sup>3</sup> Convection oven depth 22" (559mm)

Gas input ratings shown for installations up to 2000 ft.,(610m) above sea level. Please specify altitudes over 2000 ft.

Burner Ratings (BTU/Hr/kW)			
Gas Type	Open Top	Griddle/ Hot Top	Standard Oven or Convection
Natural	32,000/9.37	20,000/5.8	38,000/11.13
Propane	26,000/7.61	19,000/5.56	32,000/9.38

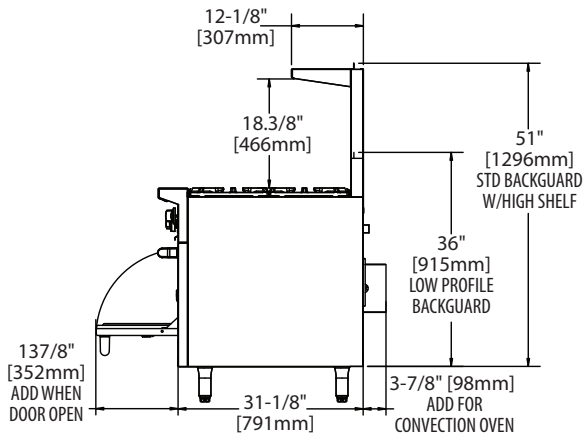
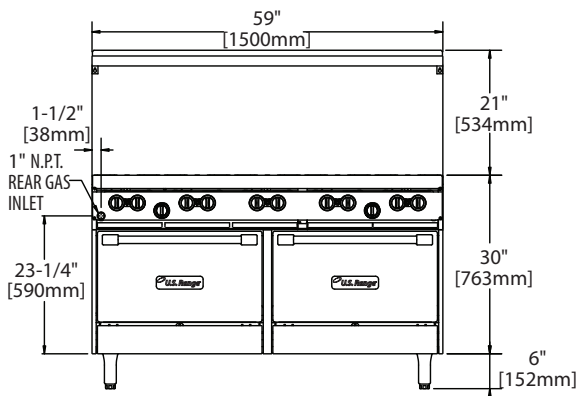
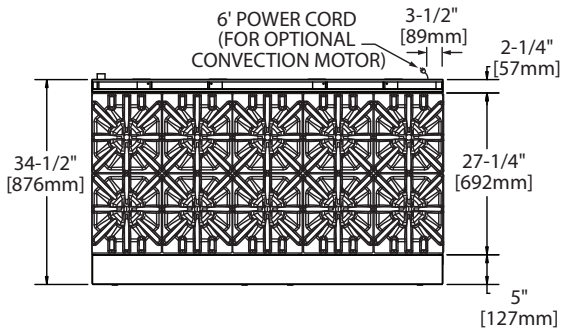

Note: Installation clearance reductions are applicable only where local codes permit.

This product is not approved for residential use.

Convection ovens with 120V, 60 Hz, 1 phase, 3.4 amps motors are supplied with 6'/1829mm cord and plug (NEMA 5-15P); 240V ,50/60 Hz, 1 phase motors are not supplied with cord and plug and must have direct connect.

Form# U60 Series (04/02/08)