



Item #: _____
Models: ICO-E-10-M / ICO-E-20-M
Product Name: SunFire Electric
Convection Oven

SunFire Electric

SunFire Electric Convection Oven

Model # ICO-E-10/20-M



Model ICO-E-10-M

Standard Features:

- Electromechanical thermostat with a temperature range of 200°F - 500°F (93°C - 260°C), and 60-minute timer
- Total of 11.0 kW loading per oven cavity
- 208 or 240 Volt, 3-Phase, (not convertible to single phase)
- Two-speed fan with 3/4 HP motor
- 60/40 dependent door design with double pane thermal window in both doors
- Interior lights
- Porcelain enameled oven interior w/coved corners
- Five (5) chrome plated oven racks on 11-position, removable rack guides
- Stainless steel front, sides, top, and legs
- Double-deck model available, (ICO-E-20-M)

Optional Features:

- Extra oven racks
- Swivel casters, set of four; two locking, (please specify single or double deck)

NOTE: Ovens supplied with casters must be installed with an approved restraining device

Specification:

Full-size, deep depth, electric convection oven with electro-mechanical thermostat, 60-minute timer and 2-speed fan. Designed as a general purpose oven for baking or roasting a variety of food products faster and at lower temperatures by circulating air throughout the oven cavity.



Garland Commercial Industries, Inc.
185 East South Street
Freeland, Pennsylvania 18224
Phone: (570) 636-1000
Fax: (570) 636-3903

Garland Commercial Ranges Ltd
1177 Kamato Road, Mississauga, Ontario
L4W 1X4 CANADA
Phone: 905-624-0260
Fax: 905-624-5669

Enodis UK LTD
Swallowfield Way, Hayes, Middlesex
UB3 1DQ ENGLAND
Telephone: 020-8561-0433
Fax: 020-8848-0041



Item #: _____
 Models: ICO-E-10-M / ICO-E-20-M
 Product Name: SunFire Electric
 Convection Oven

Width	Depth	Height		Oven Interior Dimensions			Combustible Wall Clearance	
		ICO-E-10	ICO-E-20	Height	Depth	Width	Sides	Rear
40" (1016mm)	44-1/2" (1130mm)	60" (1524mm)	72" (1829mm)	20-1/2" (520mm)	28-1/2" (723mm)	29" (736mm)	6" (152mm)	6" (152mm)

NOTE: ICO-E-10 w/Optional Casters - Overall Height = 65-1/2" (1664mm)
 ICO-E-20 w/Optional Casters - Overall Height = 71-1/2" (1816mm)

Model	Total kW Load	Nominal Amperes Per Line					
		208V / 3Ø*			240V / 3Ø*		
		X	Y	Z	X	Y	Z
ICO-E-10	11.0	32	32	28	28	28	24
ICO-E-20	22.0	60	65	60	52	56	52

* Not convertible to single-phase

Model	Shipping Information		
	Lbs.	Kg	Cube
ICO-E-10	700	315	58.0
ICO-E-20	1400	630	114.0

Model	Entry Clearances	
	Crated	Uncrated
ICO-E-10	47" (1194mm)	32-1/2" (826mm)
ICO-E-20		

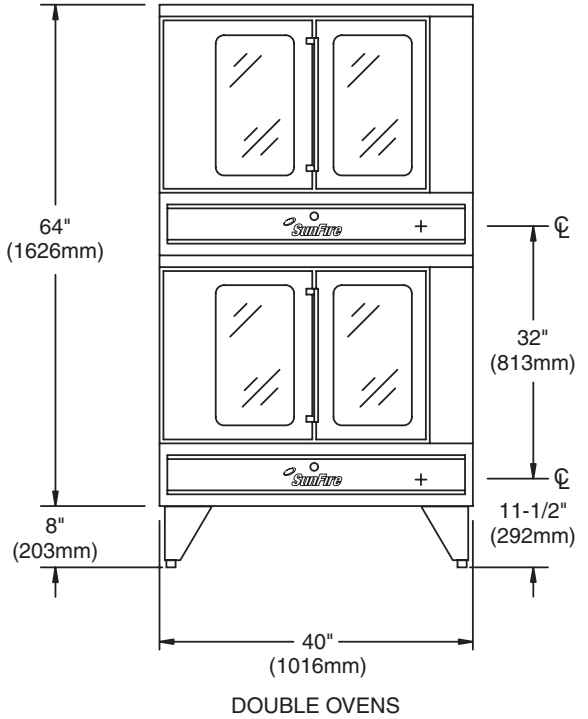
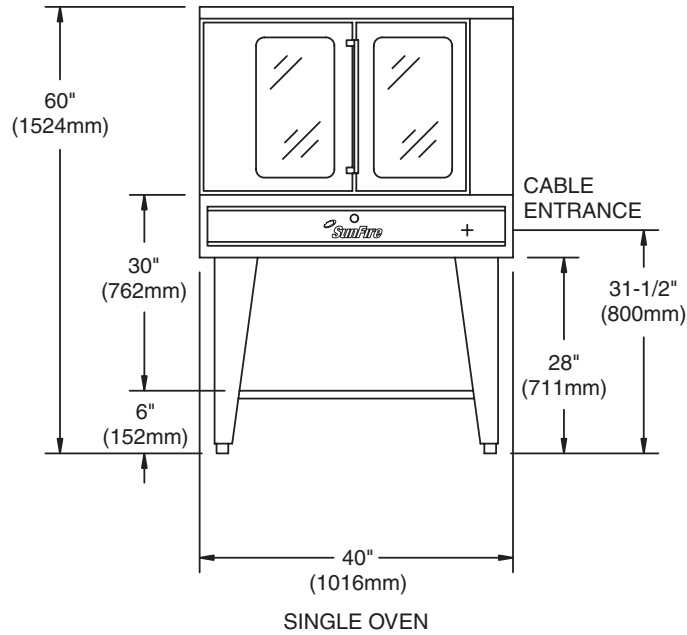
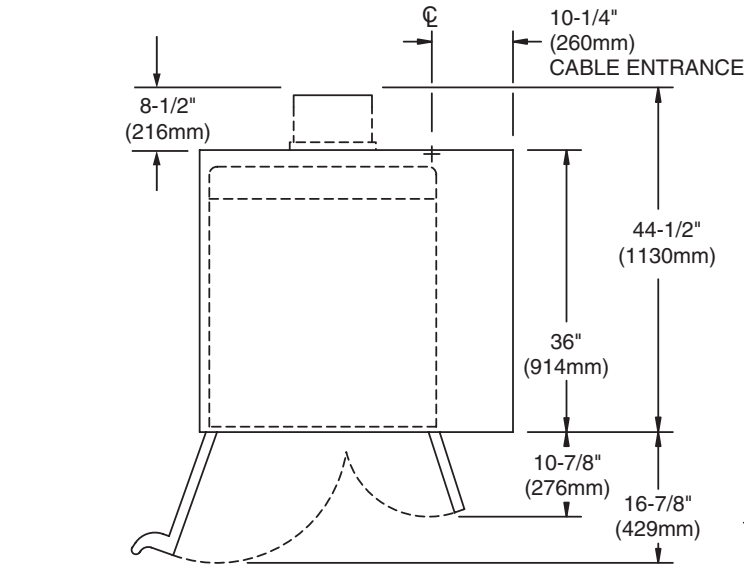

- These appliances are intended for commercial use by professionally trained personnel.
- It is the responsibility of the installer to ensure that installation complies with all national and local codes.