

# KML-451MAH

## LOW-PROFILE MODULAR CRESCENT CUBER

Item # \_\_\_\_\_

Project: \_\_\_\_\_

Qty: \_\_\_\_\_

\*AutoCad available on KCL

KML-451MAH

10/06

Item # 13186

### CUBER DIMENSIONS W x D x H

**KML-451MAH**  
30 x 27<sup>3/8</sup> x 22

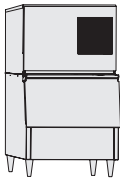

B-250

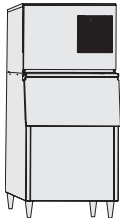

B-500



DB-200

Also available on  
Bins:  
B-700PF/SF  
B-800PF/SF  
B-900PF/SF



Large Bins:  
B-1150SS  
B-1300SS  
B-1500SS  
B-1650SS

### KML-451MAH

Air-Cooled

Shown on an optional  
B-500



- Up to 403 lbs. of ice production per 24 hours
- Durable stainless steel exterior
- Individual crescent cube
- Protected by *HoshiGuard* Antimicrobial Agent 
- CycleSaver® Design 
- EverCheck® alert system 
- Stainless steel evaporator
- Removable air filters
- R-404A Refrigerant
- Complies with California Energy Commission guidelines (CEC)



### Warranty

Valid in United States, Canada, Puerto Rico, & U.S. Territories. Contact factory for warranty in other countries.

**Three Year** - Parts & Labor on entire machine.

**Five Year** - Parts & Labor on: Evaporator.

**Five Year** - Parts on: Compressor, air-cooled condenser coil.



# KML-451MAH LOW-PROFILE MODULAR CRESCENT CUBER

## DIMENSIONS

W x D x H

KML-451MAH

30 x 27<sup>3/8</sup> x 22

• Air-cooled

## AIR-COOLED

Water Temp ° F.	50°	70°	90°
Air Temp ° F.			
70°	403	387	355
80°	391	366	328
90°	387	349	313

## UTILITY CONSUMPTION

Model Number	Ice Production Per Cycle		KWH per 100 LBS. 90/70	Potable Water Gal. per 100 lbs.	Condenser Water Gal. per 100 lbs.
	Lbs.	Cubes			
KML-451MAH	6.7	360	6.7	18.3	N/A

## SPECIFICATIONS

Model Number	Condenser	Amperage	Min. Circuit Ampacity	Shipping Weight
KML-451MAH	Air-Cooled	10.3	20A	185 lbs.

## STORAGE BINS

Model Number	Application Capacity	ARI-Rated Capacity
B-250	250 lbs.	230 lbs.
B-500	500 lbs.	360 lbs.
B-700	700 lbs.	550 lbs.
B-800	800 lbs.	600 lbs.
B-900	900 lbs.	660 lbs.
B-1150	1150 lbs.	N/A
B-1300	1275 lbs.	N/A
B-1500	1490 lbs.	N/A
B-1650	1605 lbs.	N/A

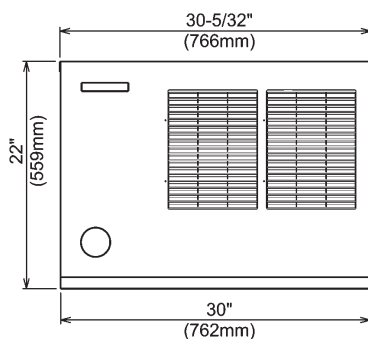

FRONT VIEW

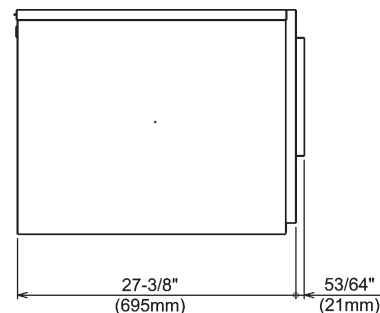

SIDE VIEW

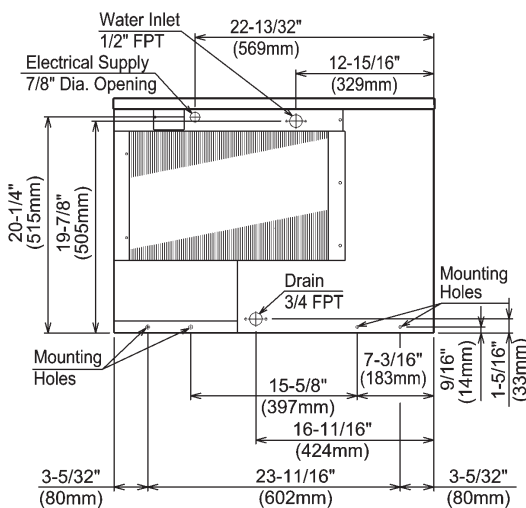

AIR-COOLED UNIT

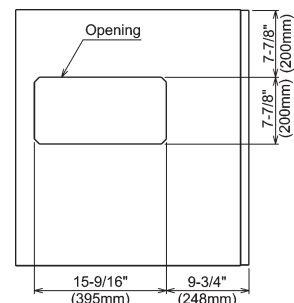

ICE DROP ZONE

## ELECTRICAL & PLUMBING/KML-451MAH

- 115/60/1
- 20 Amp Max Fuse/HACR Breaker Size
- 1/2" OD copper or equivalent independent potable water supply
- 3/4" FPT independent drain connection

## OPERATING LIMITS

- Ambient Temp Range 45 - 100°F
- Water Temp Range 45 - 90°F
- Water Pressure 10 - 113psig
- Voltage Range 104 - 127V

## SERVICE

- Panels easily removed and all components accessible for service.
- Removable/cleanable air filters



© HOSHIZAKI AMERICA, INC.

618 Hwy. 74 S., Peachtree City, GA 30269

TEL 1-800-438-6087

FAX 1-800-345-1325

www.hoshizaki.com

Printed in U.S.A.

