

KM-1340M_H

MODULAR CRESCENT ICE CUBER

Item # _____

Project: _____

Qty: _____

*AutoCad available on KCL

KM-1340M_H

1/08

Item # 13175

CUBER DIMENSIONS

W x D x H

KM-1340M_H
30 x 27^{3/8} x 41^{1/2}

CONDENSING UNIT

DIMENSIONS

W x D x H

Installation Dimensions

URC-14F

37^{13/16} x 18^{1/8} x 36^{15/16}
*with legs

Actual Dimensions

URC-14F

35^{11/16} x 15^{11/16} x 21^{15/16}

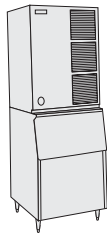

B-500

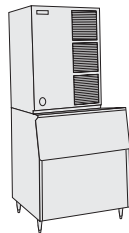

B-700

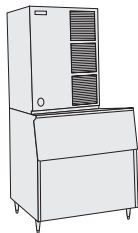

B-800

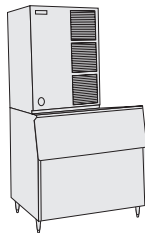

B-900

Also available on Large Bins:
B-1150SS
B-1300SS
B-1500SS
B-1650SS

KM-1340MAH

Air-Cooled

Shown on an optional
B-900



KM-1340MWH

Water-Cooled

KM-1340MRH

Remote Air-Cooled



- Up to 1401 lbs. of ice production per 24 hours
- Durable stainless steel exterior
- Protected by *HoshiGuard* Antimicrobial Agent 
- CycleSaver® design 
- EverCheck® alert system 
- Individual crescent cube
- Stainless steel evaporator
- Removable air filters (Air-cooled model only)
- R-404A Refrigerant
- Complies with California Energy Commission guidelines (CEC)

* The KM-1340MAH and KM-1340MRH are ENERGY STAR certified.

Warranty

Valid in United States, Canada, Puerto Rico, & U.S. Territories. Contact factory for warranty in other countries.

Three Year - Parts & Labor on entire machine.

Five Year - Parts & Labor on: Evaporator.

Five Year - Parts on: Compressor, air-cooled condenser coil.



© HOSHIZAKI AMERICA, INC.

618 Hwy. 74 S., Peachtree City, GA 30269

TEL 1-800-438-6087

FAX 1-800-345-1325

www.hoshizaki.com



Hoshizaki

DIMENSIONS
W x D x H
KM-1340M_H
30 x 27^{3/8} x 41^{1/2}

MODULAR ICE CUBER

- Air-cooled
- Water-cooled
- Remote Air-cooled

KM-1340M_H MODULAR CRESCENT ICE CUBER

AIR - COOLED

Water Temp° F.	50°	70°	90°
Air Temp° F.	70°	1325	1278
	80°	1289	1218
	90°	1278	1167

WATER - COOLED

Water Temp° F.	50°	70°	90°
Air Temp° F.	70°	1382	1366
	80°	1370	1344
	90°	1366	1327

REMOTE AIR - COOLED

Water Temp° F.	50°	70°	90°
Air Temp° F.	70°	1401	1357
	80°	1367	1299
	90°	1357	1251

UTILITY CONSUMPTION

Model Number	Ice Production Per Cycle		KWH per 100 LBS.	Potable Water Gal. per 100 lbs.	Condenser Water Gal. per 100 lbs.
	Lbs.	Cubes			
KM-1340MAH	28.1	1440	4.7	18.3	N/A
KM-1340MWH	28.4	1440	3.6	21.0	108
KM-1340MRH	28.7	1440	4.5	18.3	N/A

SPECIFICATIONS

Model Number	Condenser	Amperage	Min. Circuit Ampacity	Shipping Weight
KM-1340MAH	Air-Cooled	9.7	20	315 lbs.
KM-1340MWH	Water-Cooled	9.2	20	293 lbs.
KM-1340MRH	Remote Air-Cooled	9.5	20	289 lbs.

STORAGE BINS

Model Number	Application Capacity	ARI-Rated Capacity
B-500	500 lbs.	360 lbs.
B-700	700 lbs.	550 lbs.
B-800	800 lbs.	600 lbs.
B-900	900 lbs.	660 lbs.
B-1150	1150 lbs.	N/A
B-1300	1275 lbs.	N/A
B-1500	1490 lbs.	N/A
B-1650	1605 lbs.	N/A

ELECTRICAL & PLUMBING/KM-1340M_H

- 208 - 230V/60/1 (3 wire with neutral for 115V)
- 20 amp Max Fuse
- 1/2" FPT copper or equivalent independent potable water supply
- 3/4" FPT independent drain connection
- 3/8" OD Tube



© HOSHIZAKI AMERICA, INC.

618 Hwy. 74 S., Peachtree City, GA 30269

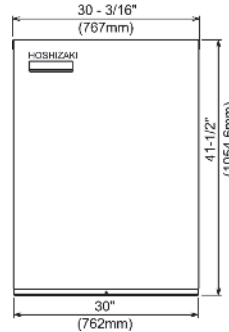

FRONT VIEW

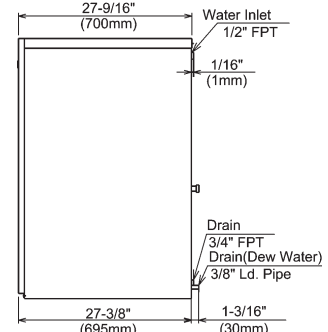

SIDE VIEW

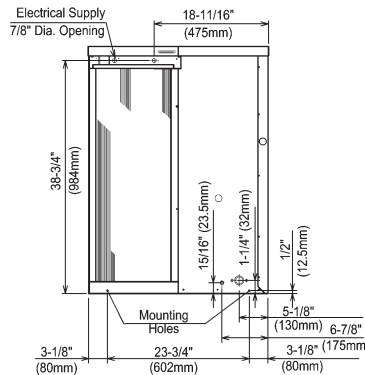

AIR-COOLED UNIT

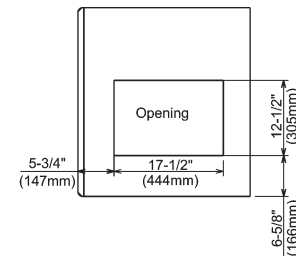

ICE DROP ZONE

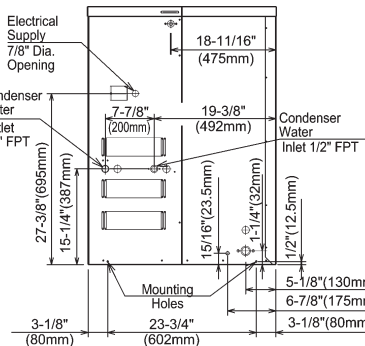

WATER-COOLED UNIT

URC-14F Remote Condenser (Sold Separately)
For Use with KM-1340MRH

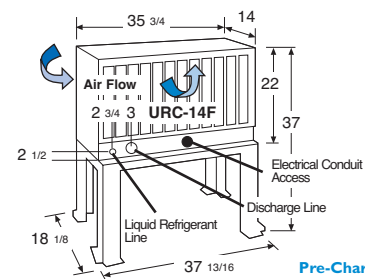

Pre-Charged Tubing Kits
(Sold Separately)
20' R404-2068-2
35' R404-3568-2
55' R404-5568-2

Voltage supply for the URC Remote Condenser is supplied from the Ice Maker. No additional circuit is required.

OPERATING LIMITS

- Ambient Temp Range 45 - 100°F
- Water Temp Range 45 - 90°F
- Water Pressure 10 - 113psig
- Voltage Range 187 - 253V

CONDENSING UNIT

- Voltage Range 104 - 127V
- Ambient Temp Range -20 - 122°F

SERVICE

- Panels easily removed and all components accessible for service.
- Removable/cleanable air filters (Air-cooled model only)

TEL 1-800-438-6087

FAX 1-800-345-1325

www.hoshizaki.com

Printed in U.S.A.

