

DM-200B

ICE AND WATER DISPENSER

Item # _____

Project: _____

Qty: _____

*AutoCad available on KCL

DM-200B

4/08

Item # 13051

DIMENSIONS

W x D x H

DM-200B

30 x 28 x 36^{3/8}

SD-200

30 x 28 x 32^{13/16}

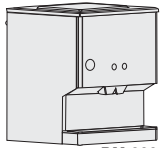

DM-200
Countertop

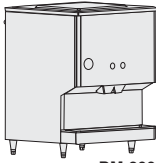

DM-200
Countertop
with optional
4" legs

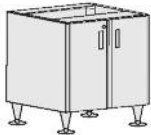

SD-200
optional
stand



DM-200B

Shown on an optional
SD-200 Stand

DM-200B

- Ice storage capacity of 200 lbs.
- Dispenses ice and water with the touch of a button
- Accommodates ice machine or manual fill
- Dispenses 7.5 lbs. of ice per minute
- Width is 30 inches
- Durable stainless steel exterior
- Unique auger agitator design dispenses individual cubes
- Fills large cups quickly
- Optional 4" legs

SD-200 Stand

- Heavy duty stand for floor model icemaker/dispenser
- Corrosion resistant stainless steel exterior
- Easy cleaning with attractive appearance
- Locking doors standard on SD-200



Warranty

Valid in United States, Canada, Puerto Rico, & U.S. Territories. Contact factory for warranty in other countries.

Two Year - Parts & Labor on dispenser.



DM-200B ICE AND WATER DISPENSER

DIMENSIONS

W x D x H
DM-200B
 30 x 28 x 36^{3/8}
SD-200
 30 x 28 x 32^{13/16}

- Ice and water dispenser
- Optional stand with locking doors

SPECIFICATIONS

Model Number	Amperage	Min. Circuit Ampacity	Shipping Weight
DM-200B	1.4	15 A	240 lbs.
SD-200	N/A	N/A	125 lbs.

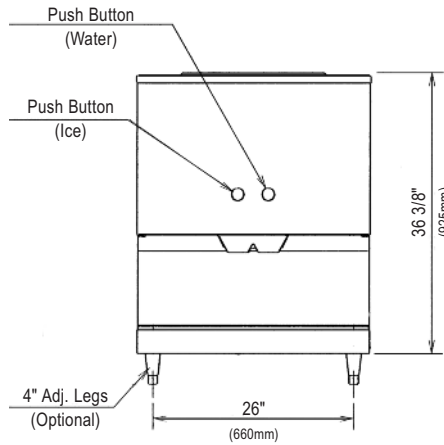

FRONT VIEW

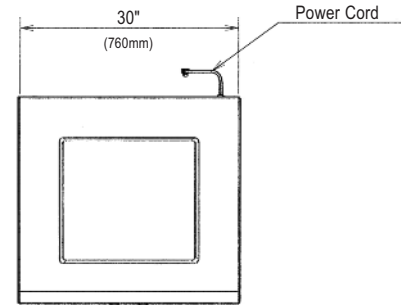

TOP VIEW

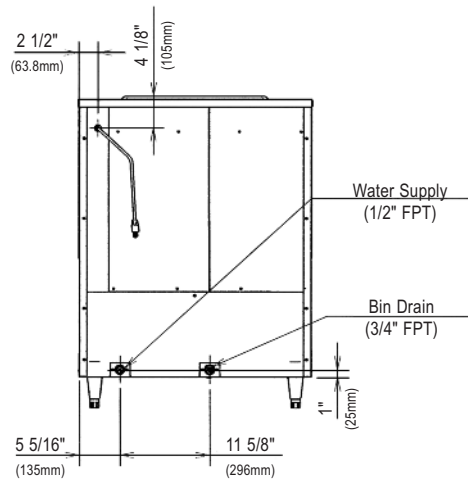
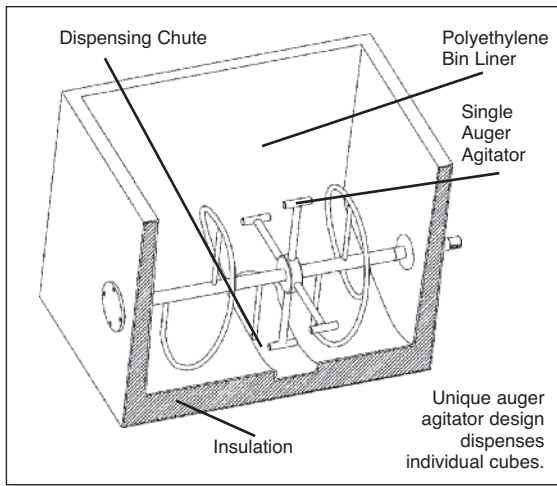

REAR VIEW

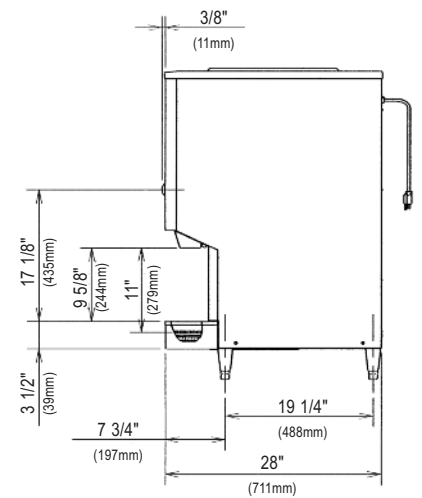

SIDE VIEW

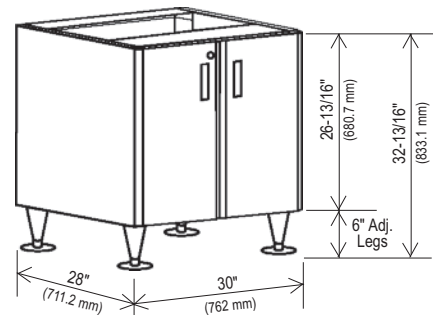

SD-200

ELECTRICAL & PLUMBING/DM-200B

- 115-120V/60/1
- 3/4" FPT drain
- 1/2" FPT water inlet

OPTIONS

- 4" leg kit
- Top Kit (HS-2036) - to accommodate KM-320M, KM-501M or KM-650M ice machines



© HOSHIZAKI AMERICA, INC.

OPERATING LIMITS

- Ambient Temp Range 45 - 100°F
- Water Temp Range 45 - 90°F
- Water Pressure 10 - 113psig
- Voltage Range 104 - 132V

SERVICE

- Panels easily removed and all components accessible for service.

