

DB-130/200H

SANITARY CUBE DISPENSER

Item # _____

Project: _____

Qty: _____

*AutoCad available on KCL

DB-130/200H

9/06

Item # 13131

DIMENSIONS

W x D x H

DB-130H

22 x 30 x 53*

*with 6" legs

DB-200H

30 x 30 x 53*

*with 6" legs

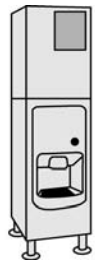

DB-130



DB-200

DB-130H

Hotel/Motel Ice Dispenser
Shown
with a KM-320MAH

DB-200H

Hotel/Motel Ice Dispenser
Shown
with a KML-600MAH



DB-130H

- Accommodates KM-320, KM-501, or KM-630 Series Cubers for 281 to 630 lbs. of ice per day
- Built-in 130 lbs. insulated polyethylene-lined ice storage bin
- Pushbutton single auger agitator dispenses ice at 20 lbs. per minute
- Card or coin mechanism optional

DB-200H

- Accommodates KML-250, KML-350, KML-450, KML-45 I, KML-600, KM-320, KM-501 or KM-630 Series Cubers for 307 to 630 lbs. of ice per day
- Built-in 200 lbs. insulated polyethylene-lined ice storage bin
- Pushbutton single auger agitator dispenses ice at 13 lbs. per minute
- Card or coin mechanism optional



Warranty

Valid in United States, Canada, Puerto Rico, & U.S. Territories. Contact factory for warranty in other countries.

Three Year - Parts & Labor.



Hoshizaki

DB-130/200H SANITARY CUBE DISPENSER

DIMENSIONS

W x D x H

DB-130H
22 x 30 x 53*

DB-200H
30 x 30 x 53*
*with 6" legs

- Hotel/Motel ice dispensers

SPECIFICATIONS

Model Number	Dispensing gear motor	Amperage	Shipping Weight
DB-130H	60 W	1.4	215 lbs.
DB-200H	60 W	1.4	240 lbs.

STORAGE BINS

Model Number	Application Capacity	ARI-Rated Capacity
DB-130H	130 lbs.	90 lbs.
DB-200H	200 lbs.	140 lbs.

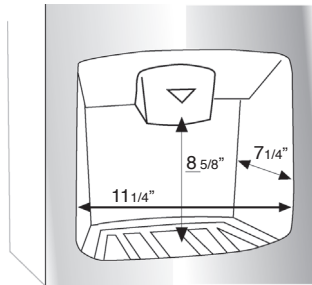

DB-130 & DB-200 Ice Dispenser Opening

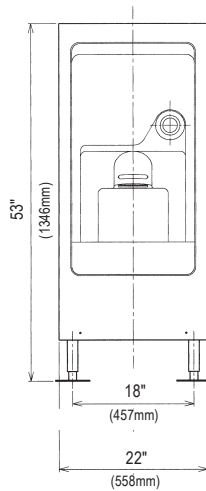
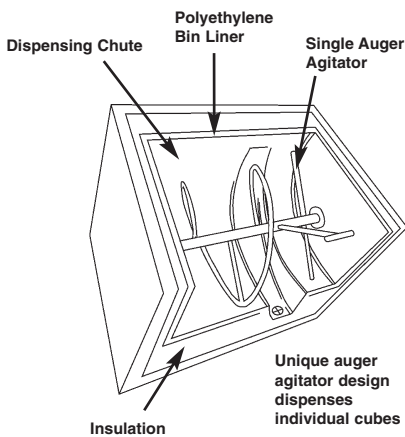

DB-130H
FRONT VIEW

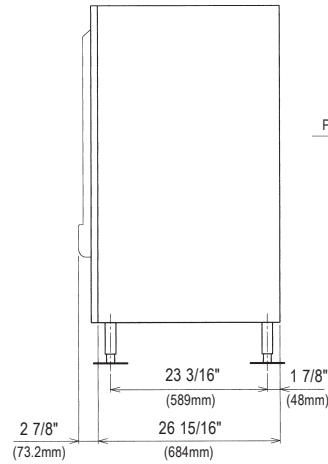

DB-130H
SIDE VIEW

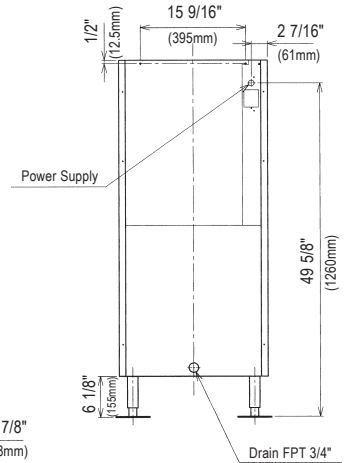

DB-130H
BACK VIEW

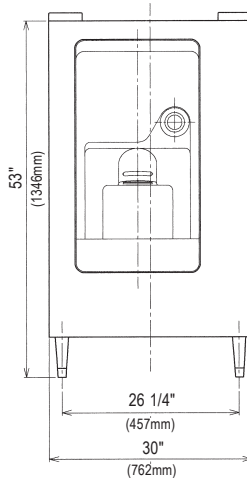

DB-200H
FRONT VIEW

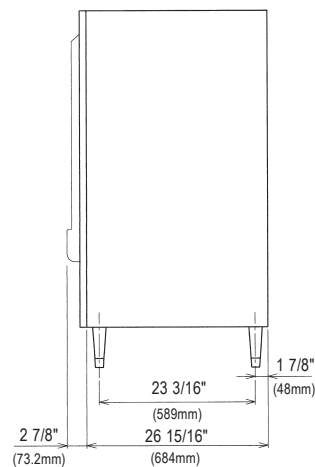

DB-200H
SIDE VIEW

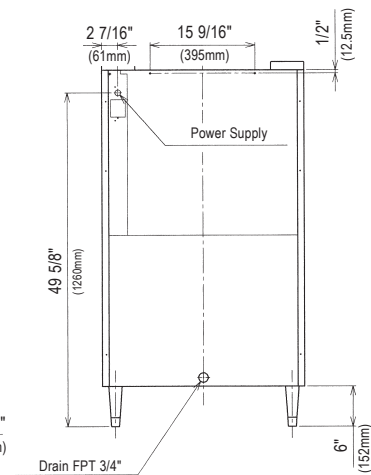

DB-200H
BACK VIEW

ELECTRICAL & PLUMBING/DB-130/200H

- 115V/60/1
- 3/4" FPT Drain



© HOSHIZAKI AMERICA, INC.

618 Hwy. 74 S., Peachtree City, GA 30269

OPERATING LIMITS

- Ambient Temp Range 45 - 100°F
- Voltage Range 104 - 127V

VENDING

- Pushbutton - Standard
- Card or Coin Mechanism - Optional

TEL 1-800-438-6087

FAX 1-800-345-1325

www.hoshizaki.com

Printed in U.S.A.

