

S-Series 1200 Ice Cube Machine



NEW



S-Series 1200
Ice Machine on B-570 Bin

- SANITATION**
We've made it simple to clean
- SAVINGS**
The perfect balance of power and efficiency
- SOUND**
Designed to run whisper-quiet
- SERVICEABILITY**
Easy access means less downtime

- Up to 1,230 lbs. (558 kgs.) daily ice production
- Only 30" (76.2 cm) wide
- Removable water distribution tube with no tools
- Food zone designed with soft, round, cove corners
- Patented cleaning and sanitizing technology
- Select components made with AlphaSan® antimicrobial
- Patented ice harvest technology reduces energy requirements

- Hinged front door for easy access
- Warranty
5-year parts and 5-year labor coverage on ice machine evaporator
5-year parts and 3-year labor coverage on ice machine compressor
3-year parts-and-labor coverage on all other ice machine, dispenser, and storage bin components



ISO 9001:2000
Quality System
Certified

America's #1 Selling Ice Machine

Ice Cube & Flake Machines • Ice Storage Bins • Ice Dispensers

Manitowoc
Foodservice Group

Manitowoc S-Series 1200

Model	Cube size	Ice production 24 hours		Power kWh/100 lbs.
		lbs.	kgs.	
SD-1202A	dice	1,010	458	5.6
SD-1203W	dice	1,120	508	4.4
SY-1204A	half-dice	1,010	458	5.6
SY-1205W	half-dice	1,120	508	4.4
Water usage/100 lbs./45.4 kgs. of Ice				
Potable Water: 18 gallons, 68 liters • Water-cooled Condenser: 150 gallons, 568 liters				

Order ice storage bin separately. "A" or "W" following model number indicates "Air" or "Water" condensing unit. Ice storage bin must be ordered separately. To order 3 phase add "3" suffix to model # (SD-1202A3).

 Certified in Accordance with ARI Automatic Commercial Ice-Cube Machines (Batch-Type) Certification Program, which is based on ARI Standard 810

Ice Machine Electric

208-230/60/1 standard. (208-230/60/3 and 230/50/1 also available.)

Min. circuit ampacity: Air-cooled: 17.1 1ph 11.4 3ph
Water-cooled: 16.1 1ph 10.4 3ph

Max. fuse size: Air-cooled, Water-cooled: 30 amps 1ph
20 amps 3ph

HACR-type circuit breakers can be used in place of fuses.

Specifications

BTU Per Hour:

19,000 (average) 28,000 (peak)

Compressor:

Nominal rating: 2 HP

Cupra-Nickel Condenser:

(Water-cooled models)
Adds protection from corrosive water elements.

Operating Limits:

- Ambient Temperature Range:**

Air and water:
35° to 110°F (1.7° to 43.3°C)

- Water Temperature Range:**

35° to 90°F (1.7° to 32.2°C)

- Water Pressure Ice Maker Water In:**

Min. 20 psi (137.9 kPa)
Max. 80 psi (551.1 kPa)

- Condenser Inlet Water In:**

(Water cooled only)
Min. 20 psi (137.9 kPa)
Max. 150 psi (1,034.2 kPa)

Air Flow Top View

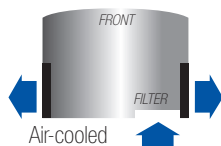

AuCS®/SI Accessory



Automatic Cleaning System purchased factory installed in the machine or as an option for field retrofit.

2 Cube Sizes Available



Half Dice
3/8" x 1 1/8" x 7/8"
(.95 x 2.86 x 2.22 cm)



Dice
1/8" x 1/8" x 7/8"
(2.22 x 2.22 x 2.22 cm)



24-HOUR PRODUCTION †								lbs. kgs.	
AIR-COOLED UNIT				WATER-COOLED UNIT					
air temp	water temp			air temp	water temp				
°F	50°	70°	90°	°F	50°	70°	90°		
°C	10°	21°	32°	°C	10°	21°	32°		
70°	1,230	1,100	1,050	70°	1,260	1,160	1,020		
21°	558	499	477	21°	572	527	463		
80°	1,190	1,070	1,010	80°	1,220	1,150	1,020		
27°	540	486	459	27°	554	522	463		
90°	1,090	1,010	930	90°	1,200	1,120	1,000		
32°	495	459	422	32°	545	508	454		

†Production for Dice and Half Dice cubes.

Space-Saving Designs



	S-1200 B-570	S-1200 B-970*
Height	79.50" 201.93 cm	79.50" 201.93 cm
Width	30.00" 76.20 cm	48.00" 121.92 cm
Depth	34.00" 86.30 cm	34.00" 86.30 cm
Bin Storage	430 lbs. 195 kgs.	710 lbs. 322.2 kgs.

Height includes adjustable bin legs 6.00" to 8.00", (15.24 to 20.32 cm) set at 6.00" (15.24 cm). For comparison purposes multiply ARI capacity by 1.3 (30%) to arrive at approximate "Application Rating Capacity." *K-00370 bin adapter required.

S-1200 on B-570 Storage Bin

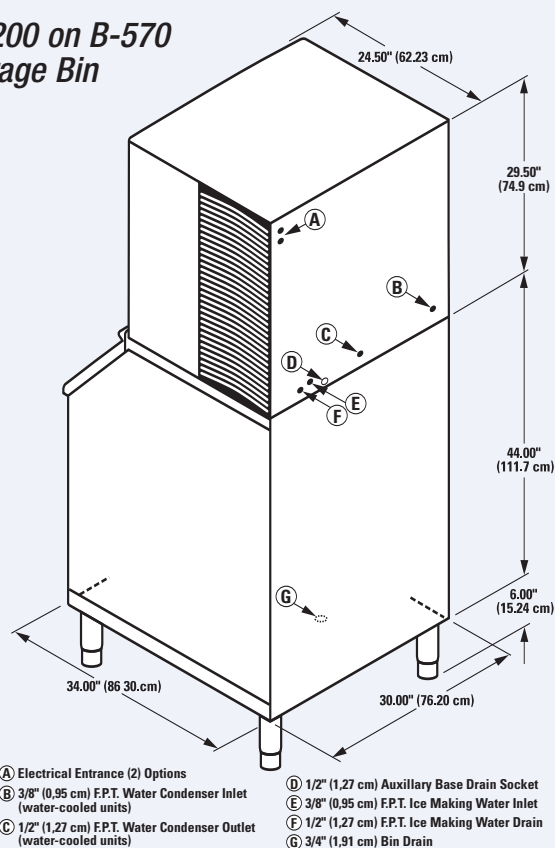

©2005 Manitowoc 2/05 Continuing product improvement may necessitate change of specifications without notice. 3199

Installation Note -

Minimum Installation Clearance: Top/Sides are 12" (30.5 cm). Back is 5" (12.7 cm).



MANITOWOC ICE, INC.
2110 South 26th Street, P.O. Box 1720
Manitowoc, WI 54221-1720, USA
Ph: 920-682-0161 • Fax: 920-683-7589
Visit us online at www.manitowocice.com

