



Z 9 6 0 0

Project _____ Quantity _____ Length _____ Item No _____



**PORTABLE
MARKET
Z9600**

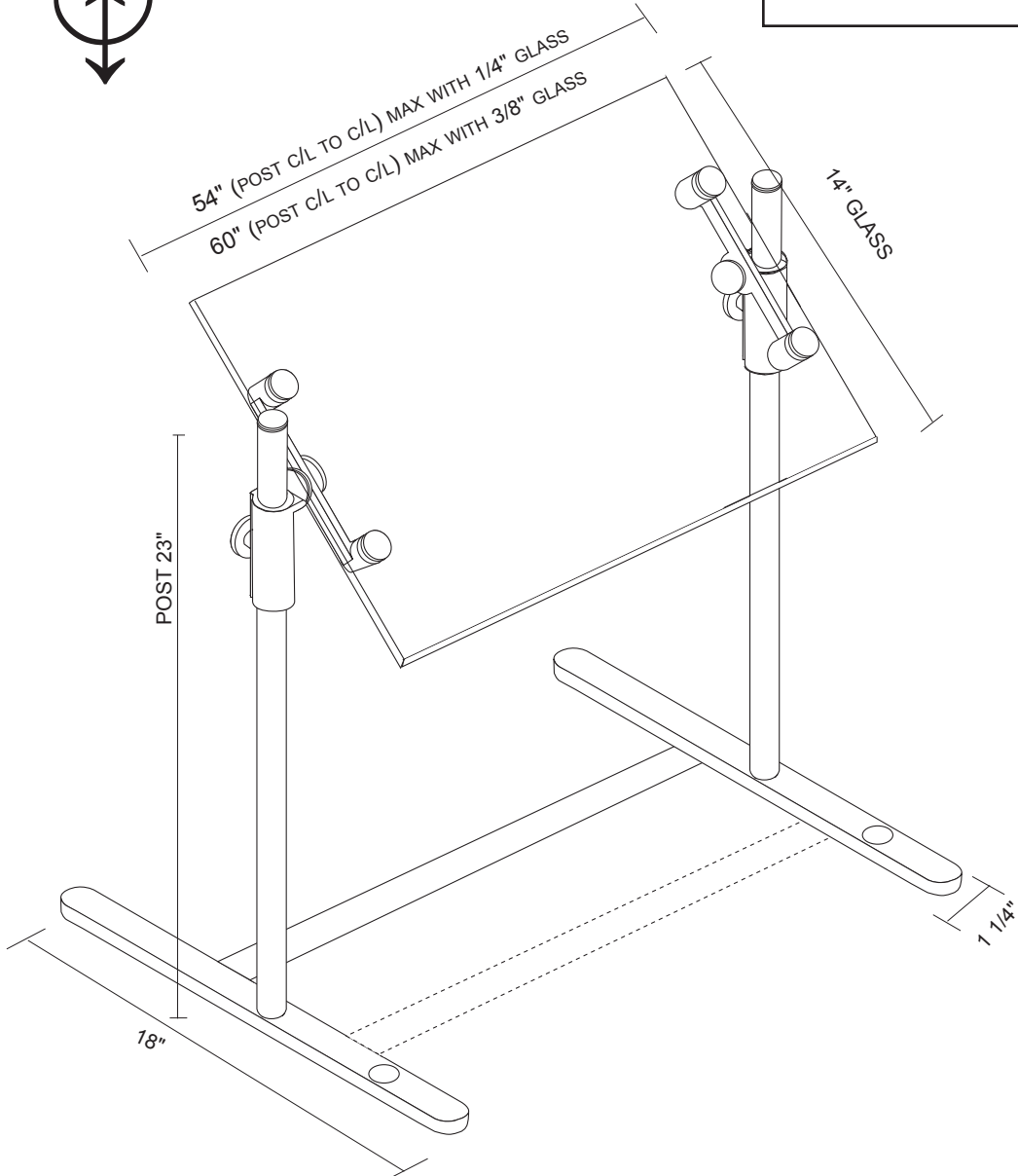

FOR A COMPLETE LIBRARY OF ISOMETRIC DRAWINGS GO TO WWW.BRASSSMITH.COM/PROFILES

PATENT NUMBER 6,588,863



Brass Smith, Inc.
3880 Holly Street
Denver CO 80207

Phone: 1-800-662-9595
Fax: 303-331-8444
www.brasssmith.com





Z 9 6 0 0

Project _____ Quantity _____ Length _____ Item No _____

NSF LISTED FINISH OPTIONS

- Brushed Aluminum
- Black
- Polished Brass
- Polished Chrome
- Smoked Copper

NSF LISTED LUSTER RAIL™ POWDER COATED FINISH OR CUSTOM COLORS

Call your local sales representative for a complete list of Luster Rail™ colors or custom Color Ordering Details

OTHER OPTIONS

- End Panels
 - Right Left Both

GLASS OPTIONS

- 1" Radius Corner (STANDARD) Square Corner
- 1/4" Tempered Glass (not for shelves) 3/8" Tempered Glass (standard for shelves)

ITEM SPECIFICATION

Item No.: _____
 Quantity: _____
 Description: Adjustable Food Shield
 Model No.: Z9600

Accessories\Options\Modifications: Provide all necessary components for a fully functional, adjustable (horizontal/vertical) food guard to include:

- Overall Length (Post C/L to C/L): _____" Maximum span is post C/L to C/L: 54" (1/4" glass) or 60" (3/8" glass).
 Note: Add 1 1/4" to Centerline Dimension to calculate overall length

- Glass Panel to be 1/4" thick by 14" wide.
 Consult factory for custom glass.
- Glass Corners to be ____ Standard: 1" radius or square
 Consult factory for custom glass corners.
- Finish to be _____.
- 1/4" thick glass end panel on ____ end(s). (Define: Left, Right or Both)

CONSULT FACTORY FOR ADDITIONAL CUSTOM MODIFICATIONS AT 1-800-662-9595.

For complete General Food Shield Performance Specifications see the *General Specification* page of this manual or go to WWW.BRASSSMITH.COM/GENSPEC.HTM

Design subject to change without notice

PATENT NUMBER 6,588,863
PRINTED 3.15.04



Brass Smith, Inc. PH: 1-800-662-9595
 3880 Holly Street Fax: 303-331-8444
 Denver CO 80207 brasssmith.com

